

# JANE'S ALL THE WORLD'S AIRCRAFT 1913

A Reprint of the 1913 Edition of All The World's Air-craft  
Edited by

# FRED T. JANE

ARCO PUBLISHING COMPANY, INC.  
New York

First published by Sampson Low Marston in 1913  
This edition published 1969 by ARCO PUBLISHING COMPANY, INC.  
219 Park Avenue South, New York, N. Y. 10003

Library of Congress Catalog Number 69-14964  
ARCO Book Number 668-01880-1

Printed in Great Britain

Published Annually.

## All the World's AIR=CRAFT.

(ORIGINALLY KNOWN AS "ALL THE WORLD'S AIRSHIPS.")  
(WAR FLYING ANNUAL.)

FOUNDED AND EDITED BY FRED T. JANE, Founder and Editor of "FIGHTING  
SHIPS" (Naval Annual), Etc.

PART A.—AEROPLANES AND DIRIGIBLES OF THE WORLD.

PART B.—HISTORICAL AEROPLANES OF THE LAST SIX YEARS.

PART C.—THE WORLD'S AERIAL ENGINES.

PART D.—AERIAL "WHO'S WHO" AND DIRECTORY.

**FIFTH YEAR OF ISSUE.**

(Founded 1909.)

LONDON:  
SAMPSON LOW, MARSTON & CO., Ltd.  
1913.

Printed by Netherwood, Dalton & Co., Phoenix Works, Rashcliffe, Huddersfield.

# CONTENTS

	PAGE
Preface	<u>7</u>
Glossary of Technical Terms	<u>9</u>
<b>PART A.</b>	
Argentine ( <b>J. Schiere</b> )	<u>15</u>
Austrian ( <b>Special Austrian Editor</b> )	<u>16</u>
Aeroplanes	<u>17</u>
Dirigibles	<u>22</u>
Belgian ( <b>J. Bracke</b> )	<u>26</u>
Aeroplanes	<u>27</u>
Dirigibles	<u>29</u>
Brazilian	<u>31</u>
British	<u>32</u>
Aeroplanes	<u>37</u>
Dirigibles	<u>60</u>
British Colonies, Etc.	<u>63</u>
Bulgarian	<u>66</u>
Central American Republics	<u>67</u>
Chilian	<u>68</u>
Chinese	<u>69</u>
Danish	<u>70</u>
Dutch ( <b>J. Schiere</b> )	<u>71</u>
French ( <b>Special French Editor</b> )	
Aeroplanes	<u>73</u>
Dirigibles	<u>109</u>
German ( <b>Special German Editor</b> )	<u>126</u>
Aeroplanes	<u>131</u>
Dirigibles	<u>151</u>
Greek	<u>168</u>
Italian ( <b>Special Italian Editor</b> )	<u>169</u>
Aeroplanes	<u>172</u>
Dirigibles	<u>176</u>
Japanese ( <b>Partly Official</b> )	<u>180</u>
Aeroplanes	<u>181</u>
Dirigibles	<u>182</u>
Mexican	<u>183</u>

Norwegian	<a href="#">184</a>
Peruvian	<a href="#">185</a>
Portuguese (J. Schiere)	<a href="#">186</a>
Roumanian	<a href="#">187</a>
Russian	<a href="#">188</a>
Aeroplanes	<a href="#">190</a>
Dirigibles	<a href="#">191</a>
Servian	<a href="#">193</a>
Spanish	<a href="#">194</a>
Swedish (Lieut. Dahlbeck)	<a href="#">196</a>
Swiss (Special Swiss Editor)	<a href="#">198</a>
Turkish	<a href="#">200</a>
Uruguay	<a href="#">200</a>
United States (W.L. Jones)	<a href="#">201</a>
Aeroplanes	<a href="#">202</a>
Dirigibles	<a href="#">220</a>
<b>PART B.</b>	
Historical Aeroplanes of the Last Six Years	<a href="#">1B et seq.</a>
<b>PART C.</b>	
Principal Aeroplane Engines	<a href="#">1C</a>
Austrian (W. Isendahl)	<a href="#">2C</a>
Belgian	<a href="#">2C</a>
British	<a href="#">3C</a>
French	<a href="#">4C</a>
German (W. Isendahl)	<a href="#">8C</a>
Italian	<a href="#">11C</a>
Swiss	<a href="#">12C</a>
U.S.A.	<a href="#">13C</a>
<b>PART D.</b>	
Aerial "Who's Who"	<a href="#">1D</a>
Classified Aerial Directory	<a href="#">12D</a>
Alphabetical Index—Aeroplanes	<a href="#">end of</a>
Alphabetical Index—Dirigibles	<a href="#">book</a>



## PREFACE.



s conjectured last year, considerable further changes have been produced in this edition.

When, some five years ago, work on this annual was first commenced, the military aviator was an idle dream. Fighting men in dirigibles were a bare possibility; but nothing more than that. Every amateur building an aeroplane (or even merely intending to build one) in his back garden was a possible "conqueror of the air." The aeroplane was going to oust the motor car as a sporting vehicle—everyone was quite certain about that! Beyond that, nothing!

To-day everything is completely changed and except as a war machine the aeroplane is of little interest or use to anyone. A few civilian aviators are still flying, but in practically every case they are doing so in connection with the business aspect of the question. There is no "sport of aviation" such as the prophets foretold a few years ago.

An increasing number of people obtain their pilot certificates and lists of these are still given, although the title of "aviator" is in the bulk of cases somewhat of a courtesy one, since so few keep on flying once they have secured their brevets.

It is as a *war machine* that the aeroplane has come into its own. The Italian aeroplanes over and over again proved their utility in Tripoli. Although in the Balkan War aircraft were less in evidence than many expected, this may be attributed to the peculiar circumstances of the campaign and also to the scarcity of available machines.

Every country is now engaged in forming its aerial fleets. How far the naval and military branches will coalesce, or how far they will differentiate remains to be seen. The probabilities, at present, all point in the latter direction, and that just as an army is made up of cavalry, infantry, artillery, etc., and a navy of battleships, cruisers, torpedo craft and submarines, so the sky fleets seem destined to consist of groups of different types of machines, each type designed for some special purpose.

The increased war utility of aircraft has necessitated an extension of the pages devoted to organisation of military aviation, etc. The details given are by no means as full as I could wish; but all organisations are being so continually changed owing to increased experience that satisfactory data are not very easy to come by.

During the past twelve months or so we have learned at least one or two important things. The mere fact of the possession of aeroplanes by a nation is a military factor of comparatively little importance. A nation possessing next to no aeroplanes can easily acquire a few hundreds in case of emergency *if she has the people to build them*. The real problem is two-fold. First, of course, is the possession of trained and efficient aviators to fly the machines. Naval and military officers who have merely secured their brevets at a flying school are of no immediate value; civilians of the same kind are of still less utility.

Second to this is the productive capacity of any country; which may roughly be gauged from the number and importance of its firms engaged in construction.

These points cannot too strongly be enforced. The air strength of any nation in case of war resides in its efficient flying men and in its own productive capacity. The next war will see aircraft quite as much "contraband" as warships, and the nation which relies upon aerial

imports will be foredoomed at once. One month is probably the utmost effective life of an aeroplane on hard active service and it may well be a good deal less. And firms capable of building efficient machines cannot be improvised.

A remarkable feature of the last twelve months has been the recrudescence of the dirigible, which is now in far greater esteem than it was a year ago, or for that matter, ever before. In the past there is no doubt that progress was hampered by arguments between the advocates of "heavier than air" and "lighter than air," and a curious notion that the one could only exist at the expense of the other.

Such ideas are now dead, and it is recognised that for war purposes both have their uses and that both are interdependent. It is not quite yet realised how intense this interdependence is likely to be.

Briefly the present situation may be summed up as follows: the dirigible has enormous potentialities for attack on fortified bases and the like, but its powers of defence, guns or no guns, are very slight. A single aeroplane should be able to disable or destroy without very great difficulty the finest dirigible yet built (supposing it able to find the airship in the vastness of the air). The damage that a single aeroplane can do to land defences or ships is, however, entirely trivial—at any rate at present.

Hence the aerial war unit already formed in Germany, and likely to be in existence everywhere else ere another year or so has passed. This unit is a dirigible of great offensive powers, associated with a number of aeroplanes presumably intended to defend it and ward off and defeat attack by hostile aeroplanes.

This is merely the crude beginning, it seems reasonably safe to prophecy that in the early future the aerial war-unit will be made up somewhat as follows:—

- (a) An offensive dirigible, carrying the maximum of bombs, etc.
- (b) One or two dirigibles carrying oil and petrol for the aeroplanes—possibly capable of dealing with all minor repairs and of carrying a certain number of aeroplanes on board.
- (c) A number of war aeroplanes specially designed for fighting other aeroplanes and attacking hostile dirigibles as chances may occur.
- (d) A few very swift one man aeroplanes which will be the eyes of the unit.

This seems an early certainty. After all it merely reproduces for the air what centuries of experience have shewn to be essential for fleets and armies.

The matter is a fascinating subject for speculation; but in connection with a work that exists merely to deal with things as they are at present, is perhaps, better not now pursued further. One point, however, may perhaps be mentioned, and that is that victory or defeat in aerial warfare seems likely to depend upon which side can first destroy the other's bases. A base-less

dirigible will not live long. This is likely to lead to very great attention being paid at an early date to anti-aircraft guns and other devices for the defence of aerial bases.

Reverting to the arrangement of the present edition, a few words may be said about some of the changes. As stated last year the clumsy old system of grouping monoplanes, biplanes, etc., separately has been abolished. So many firms specialise in both that any such grouping could only lead to confusion.

A tabular system has been generally adopted for most new matter. This will be found far more convenient for reference, and of course, saves a great deal of space.

The effective age of aeroplanes is somewhat of a vexed question, for while one year probably represents the really effective war utility endurance, even in peace time, school life is more or less indefinite and so is ordinary private life. Consequently—although "dead machines" are excluded it has not been possible to draw an exactly uniform age limit line beyond that. Speaking generally modern machines represent as a rule detail improvements rather than the complete changes of the past. For example, the gap between 1911 and 1913, is far less than the gap between 1909 and 1911. This fact is beginning to make itself felt in war machines.

In Part B an attempt has been made to collect illustrations of aeroplanes of the past which for one reason or another possess an historical interest. This section is remarkable for two totally different things (1) the early anticipations of some modern practice, and (2) the past prevalence of certain other ideas which are now totally extinct.

Part C deals with aero-engines. It is mainly remarkable—in comparison with past issues—for the large number of engines which have ceased to exist. It is probably still too ample; as a year hence quite half the makers still recorded are likely to disappear. The mere ability to construct motor car engines is no longer of value. The aeroplane engine designer needs to be a specialist. The absolutely ideal aero-engine no doubt yet remains to be produced; but meanwhile the tendency of users to concentrate upon fewer makes is increasingly evident, despite the fact that the best engine for one particular type of machine is not necessarily the best for some other type.

In conclusion I tender my most grateful thanks to all those who have so kindly collaborated with or for me in the various sections. The book is still some way from being near my ideal, but I have every hope that this edition will be generally considered a very considerable improvement upon previous issues.

FRED T. JANE.

*Bedhampton,*  
Hants.,  
England.

## GLOSSARY OF TECHNICAL TERMS, Etc.

ENGLISH.	DUTCH.	FRENCH.	GERMAN.	ITALIAN.	NO
Abaft	Achterste deel	Arrière	Hinter	A poppa	
Accessories	Onderdeelen	Accessoires	Zubehör	Accessori	
Accumulator	Accumulator	Accumulateur	Akkumulator	Accumulatore	
AEROPLANE	Dekvlieger	Aéroplane	Drachenflieger	Aereoplano	
Aeronaut	Luchtvaarder	Aéronaute	Luftschiffer	Aereonauta	
		Aviateur			
Aerostat	Luchtbal	Aérostât	Freiballon	Aereostato	
Aft	Achterdeel	Arrière	Hinten	Addietro	
After (rear)	Achter	Arrière	Hinterer	Poppa	
Air-cooled	Luchtgekoeld	Refroidit par Pair	Luftgekühlt	Raffredda ad aria	
Angleiron	Hoekÿzer	Cornière	Eck Schiene	Ferro ad angolo	
Anti-friction metal	Wit metaal	Métal anti friction on regule	Lagermetall	Metallo bianco (anti frizione)	
Aviation	Vliegttechniek	Aviation	Flugtechnik	Aviazione	
Babbit Metal	Babbits metaal	Métal Babbitt on regule	Lagermetall	Metallo Babbitt	
Balance	Evenwicht	Equilibre	Gleichgewicht	Equilibrio	
Ball bearings	Kogellagers	Coussinets à billes	Kugel Lager	Cuscinetti a sfera	
Ballonet	Luchtzak	Ballonet	Ballonet	Palloncino compensatore	
Battery	Batterÿ	Batterie	Batterie	Pila a secco	
Bearing metal	Kussenmetaal	Métal pour les coussinets on regule	Lager metall	Metallo par cuscinette	
Behind	Achter	Derrière	Hinter	Di dietro	

Bevel geared	Kegelraderwerk	Engrenage Conique	Konischer Antrieb	Ingranaggio conico	DIRIGIBLE	Motorballon	Dirigeable: Aéronat	Motorluftschiff	Dirigibile
Biplane	Tweedekker	Biplan	Zwei decker	Biplano	Diameter	Middellÿn	Diamètre	Durchmesser	Diametro
Blades (of propeller)	Bladen (der schroef)	Pales	Flügel	Pale delt'elica	Direct driven	Direct gekoppeld	Prise directe	Direkter Antrieb	Presa diretta
Body	Romp	Fuselage	Körper	Telaio o chassis	Electric welding	Electrische Lassching	Soudure électrique	Elektrisches Schweißen	Soldatura elettrica
Bolt	Bout	Bonlon	Bolzen	Bollone	Elevator (horizontal rudder)	Hoogtestuur	Gouvernail de profondeur	Hohensteuer	Timone orizzontale
Box-kite	Kabel-vlieger	Cerf-volant	Drachen	Aquilone a celle	Engine	Motor	Moteur	Motor	Motore
Bracket	Klamp	Tasseau	Stütze	Sostegno	Fan	Ventilator	Ventilateur	Ventilator	Ventilatore
Brake	Rem	Frein	Bremse	Freno	Fittings	Fittings	Garniture	Garnitur	Armamento
Breadth	Breedte	Largeur	Breite	Larghezza	Flight	Vlucht	Vol	Flug	Volo
Canvas	Doek	Toile	Leinwand	Tela	Flown	Gevlogen	Volé	Geflogen	Volato
Car	Gondel	Nacelle	Gondel	Navicella	Fore	Voor	Avant	Vorderer	Ouvanti
Carburetter	Vergasser	Carburateur	Vergaser	Carburatore	Forward (in front)	Van Voren	En avant	Vor	Davanti
Casting	Gietstuk	Moulage	Guss Stück	Getto	Frame	Romp	Fuselage	Rahm	Telais
Centre of Gravity	Zwaartepunt	Centre de Gravité	Schwerpunkt	Centro di gravità	Framework	Geraamte	Fuselage	Gerüste	Intelaiatura
Chain driven	Door ketting gedreven	Transmission par chaine	Ketten antrieb	Trasmissione a catena	Gas bag	Gaszak	Enveloppe	Luftballon (Hülle)	Involucro
Chassis	Gestel	Chassis	Motor Rahmen	Chassis	Geared to	Vertand	Multiplié à	Uebersetst auf	Moltiplicato a
Circumference	Omtrek	Circonféance	Umfang	Cuconferenza	Gear driven	Met tandrad-overbrenging		durch Zahnrädern getrieben	Trasmissione a ingranaggi
Clutch	Haak	Embrayage	Kupplung	Innesto	Girder	Balk	Poutre	Balken	Longarin
Connection	Schakeling	Couplage	Kupplung	Conessione	Glider	Glÿdvlieger	Planeur	Gleitflieger	Apparecehio a planare
Control	Stuurinrichting	Direction	Lenk Übersetzung	Meccanismo di direzione	Gondola	Gondel	Nacelle	Gondel	Navicella
Coupled	Gekoppeld	Jumelé	Paarweise	Accoppiato	Helices	Schroeven	Helices	Schranben	Eliché
Crank shaft	Krukas	Arbre à manivelle	Kurbelwelle	Albero delle manovelle	Helicopter	Schroefvlieger	Helicoptère	Schraubenflieger	Elicoplano Elicottero
Cylinder	Cÿlinder	Cylindre	Zylinder	Cilindro	Horizontal plane (in a)	Horizontaalvlak (in een)	Plan horizontal	Horizontal fläche	Piano orizzontale
Die cast Bearings	Ondermetaallager	Coussinets moutés encogiulles	Schalenguss Lager	Cuscinette fusi in conchiglia	Horse power	Paardekracht	Puissance en chevaux	Pferdekraft	Forza cavalli

Hydrogen	Waterstof	Hydrogène	Wasserstoff	Idrogens	Pivot	Tap	Pivot	Gewinde Zapfen	Perno
Ignition	Ontsteking	Allumage	Zündung	Accensione	Planes	Vlakken	Plans	Flächen	Piani
Inch	Duim	25.39 m/m.	25.39 m/m.	Pollice = 25.39 m/m.	Plug	Kaars, stop	Bougie	Zünd Kerze	Candela
Inclination	Helling	Inclination	Schrägstellung	Inclinazione	Pound (lb.)	Eng pond = 0,453 K.G.	0.453 kg.	0.453 kg.	Libbra = 0.453 kg.
Keel	Kiel	Carène	Kiel	Chiglia	Pressure	Druk	Pression	Druck	Pressione
K.P.M. (kilometres per hour)	K.P.U. (kilom. per uur)	Kilometres par heure	Kilometre pro Stunde	Chilometre all'ora	Propeller	Schroef	Helice	Schraube	Eliche
Kite	Vlieger	Cerf volant	Drachen	Aquilone	Quadruplane	Vierdekker	Quadruplan	Vier decker	Qudruplani
Length	Lengte	Longueur	Länge	Lunghezza	Quintuplane	Výfdekker	Quintuplan	Fünf decker	Quintuplani
Lining metal	Lagermetaal	Métal pour garnir less coussinets ou régule	Lagermetall	Metallo per bronzine dei cuscinetti	Radiator	Koeler	Radiateur	Kühler	Radiatore
Lower (planes)	Onder (vlakken)	Inferieur (plans)	Untere Flächen	Piani inferiori	Rear (in)	Achterkant (aan de)	En arrière	Hinten	Indictro
Magneto	Magneet	Magneto	Magnet	Magneto	Reduction gearing	Reductie- overbrenging	Engrenage de demultiplication	Übersetzung	Ingranaggi di ridugione
Maximum	Maximum	Maximum	Maximum	Massimo	R.P.M. (revolutions per minute)	Omw. per minuut	Tours	Umlauf	Giri al minuto
Middle (plane)	Midden (vlak)	(Plan)au milieu	Mittel Deck	Piano medio	Rigid	Stýf	Rigide	Starr	Rigido
Mile	Mýl	Mile	Meile	Miglio	Rises	Stýgt	S'élève	Hebt sich	Si eleva
Military	Militair	Militaire	Militärische	Militare	Rubber	Gummi	Caoutchouc	Gummi	Gomma
Miscellaneous	Verskillend (allerlei)	General	Verschiedenes	Diversi	Rudder	Roer, Stuur	Gouvernail	Steuer	Timone
Monoplane	Eendekker	Monoplan	Ein decker	Monoplano	Section	Doorsnede	Section	Durchschnitt	Regione
Motor	Motor	Moteur	Motor	Motore	<b>Semi-rigid</b>	Halfstýf	Demi-rigide	Halb Starr	Semi-rigido
M.P.H. (miles per hour)	M.P.U. (mýl per uur)	Vitesse	M.P.S.	Miglia all'ora	Span	Spanwýdte	Envergure	Spanweite	Apertura
Multiplane	Veeldekker	Multiplan	Vieldecker	Multiplano	Speed	Snelheid	Vitesse	Geschwindigkeit	Velocita
Nacelle	Schuitje	Nacelle	Gondel	Navicella	Stability	Evenwicht	Stabilité	Gleichgewicht	Stabilità
Non-rigid	Slap	Souple	Unstarr	Non-rigido— flessibile	Stabilising fins	Evenwichtsvlakken	Ailerons	Gleichgewichtsflächen	Piani stabilizzaton
Petrol (gasoline)	Benzine	Essence	Benzin	Benzina	Steel	Staal	Acier	Stahl	Acciaio
Pilot (driver)	Bestuurder	Flyer: Aviateur	Führer	Aviatore	Steering Gear	Stuurtoestel	Direction	Steuerung	Meccanismo di direzione
					Steering Wheel	Stuurwiel	Volant	Steuerrad	Volante di direzione

Supporting surface	Draagvlak	Surface	Tragfläche	Superficie di sostegno
Surfaces	Oppervlakken	Surfaces	Flächen	Superfici
Suspension	Ophanging	Suspension	Aufhängung	Sospensioni
Switch	Omschakelaar	Interrupteur	Schalter	Interruttore
Tail	Staart	Queu	Schwanz	Coda
Total weight	Totaal gewicht	Poids totale	Gesamtlast	Peso totale
Transmission Shaft	Overbrengingsas	Arbre de transmission	Transmissions Welle	Albero di trasmissione
Trial	Proef	Essai	Probe	Prova
Triplane	Driedekker	Triplan	Drei decker	Triplano
Universal Joint	Kogelgewricht	Joint universel	Kardan	Guinta universale
Unladen	Onbelast, leeg	à vide	Leerlaufend	
Upper (planes)	Boven (vlakken)	Superior	Ob ere	Piani Superior
Useful lift	Nuttier last	Poids utile	Outlast	Forza utile di elevation
Valve	Kelp	Soup ape	Lentil	Valvular
Vertical plane (in the)	Vertical vlak (in het)	Plan vertical	(in der) Vertikalfäche	Neal piano verticale
Vertical rudder	Zÿstuur	Gouvernail verticale	Seitensteuer	Timone verticale
Volume	Inhoud	Volume	Inhalt	Volume
Water-cooled	Watergekoeld	Refroidissement par eau	Wasserkühlung	Raffreddata ad acqua
Weight	Gewicht	Poids	Gewicht	Peso
Wheels	Wielen	Roues	Raeder	Ruote
Wings	Vleugels	Ailes	Flügel	Ali
Wood	Hout	Bois	Holz	Legno
Yard (measure)	Yard (maat) = 0,914 M	0.914 mètres	0.914 meter	Jarda=0.914 m.



# AEROPLANES & DIRIGIBLES.

## ARRANGED BY NATIONALITIES IN ALPHABETICAL ORDER.

*Note.*—Every nation is given in the following fixed order:—

List of Aerial Societies and Clubs, with addresses and Secretaries where possible.

List of Aerial Journals, with addresses, price, and dates of publication.

List of Flying Grounds for aeroplanes, and hangars for dirigibles (if any).

List of Military and Naval Machines and aviators.

List of Private Aviators, total of machines, etc.

AEROPLANES in alphabetical order, *uniform scale* plans, and particulars.

DIRIGIBLES: Military and private *uniform scale* plans, and particulars.

*Note.*—The uniform scale of dirigible plans is a smaller scale than that used for aeroplanes.

## ARGENTINE.

(Revised by J. SCHIERE, Aeronautical Engineer and Librarian, Dutch R. Ae. C.)

### Aerial Societies:—

Ae.C., Argentino, 561, S. Martin, Buenos Ayres.

### Aerial Journals:—

Boletin del Ae.C., Argentino (Monthly).

### Flying Grounds:—

**Aerodromo Villa Lugano.** (P. Castabert, Director.)

**Aerodromo del Palomar.** (Military).

### Military Aviation.

At the end of 1912 there were 6 military aeroplanes (3 *Bleriot*, 1 *Castabert*, 1 *Nieuport*, and 1 *H Farman*)—all 1912 models.

Marcel Paillette is director of the military flying ground at the Palomar Aerodrome.

More machines will be added and by the end of the present year it is probable that a very considerable air force will exist.

### Private Aviators.

Bregi, Henri (A.C.F. 26)

de Bruyn, A. (3)

Castabert, B. (1)

Fels, T. (9)

England, Gordon F.C. (British p.)

Goffre, C.A. (4)

Hentsch, H. (5)

Mascias, A.R. (8)

Melchior, E. (11)

Newbury, G. (6)

Origone, M.F. (10)

Paillette, Marcel (French p.)

Parravicini, F. (7)

Roth, J.A. (2)

Valleton A. (French p.)

### PABLO CASTAIBERT. Monoplane.

Type	1911. <i>Bleriot-Hanriot</i> type.	1912. <i>Bleriot</i> type.
Length	26½ feet (8.15 m.)	28 feet (8.47 m.)
Span	29 feet (8.80 m.)	30 feet (9.35 m.)
Area	206 sq. ft. (19-20 m <sup>2</sup> .)	194 sq. ft. (18 m <sup>2</sup> .)
Weight (total)	705 lbs. (320 kgs.)	617 lbs. (280 kgs.)
Motor (h.p.)	25 Anzani	50 Gnome
Speed (p.h.)	46½ m. (75 km.)	50 m. (80 km.)

*Note.* Both fly well. Description in *Boletin de Ae.C. Argentino*.

## AUSTRO-HUNGARIAN.

(By our Austrian Editor.)

### **Aerial Societies:—**

Cesky Club Automobilistn. Aviatische Sektion. (Prague.)  
Deutscher Luftfahrt-Verein in Boehmen (Teplitz-Schoenau).  
Flugtechnischer Verein für Mähren (Brunn.).  
Flugtechnischer Verein in Schlesien (Troppau).  
Flugtechnischer Verein in Steiermark (Graz, Schmiedgasse 31).  
K.k. Oesterreichischer Flugtechnischer Verein (Wienstrasse 31, Vienna).  
Kärtner Automobil Club (Klagenfurt.)  
Klub Awiata (Obertynska Str. 8, Lemburg, Galicia).  
Magyar Automobil Club (Budapest).  
Magyar Athletikai Club (Abt. für Aviatik) Budapest.  
Oberösterreichischer Verein f.L. in Linz (Landstr. 119, Linz).  
Oesterreichischer Aero Club (St. Annahoff, Vienna) (*formerly Wiener Aero Club*).  
Oesterreichischer Flugsport Club (Breitegasse 7, Vienna VII).  
K.k. Oesterreichischer Flugtechnischer Verein (Weinstrasse 31, Vienna).  
Oesterreichischer Luftflotten-Verein (Vienna).  
Oesterreichischer Wintersportklub (Vienna). *Glider club*.  
Verein für L. in Tirol (Innsbruck).

### **Aerial Journals:—**

*Allgemeine Automobil Zeitung*. (Fleischmarkt 5, Vienna) weekly.  
*Allgemeine Sport Zeitung*. (St. Annhoff, Vienna) weekly.  
*H.P. Fachzeitung für Automobilismus und Flugtechnik*. (Vienna) weekly.  
*Oesterreichische Flugzeitschrift*. (Aspernplatz, Wien I) fortnightly.  
*Wiener Luftschiffer-Zeitung*. (St. Annahof, Vienna) fortnightly.

### **Flying Grounds:—**

Military.  
**Fischamend** (Principal Army).  
Goerz.  
Zaule b. Triest.

Naval.  
Pola.

Private.  
**Aspern bei Wien**, Vienna.  
Rakos bei Budapest.  
Wiener Neustadt.

## AUSTRO-HUNGARIAN AEROPLANES.

### Military Aviation: General.

In June, 1912, a central aeronautical committee was created, under the presidency of Prince Fürstenberg, to deal with the creation of a national aerial fleet. One of the objects is the perfection of the Austrian machines and factories.

About the same date, Pola was selected as a naval aviation school, and two *Paulhan-Curtiss* hydro-avions purchased.

In August the record making *Lohner* was purchased for the Army.

During September Captain Odolek tested before the military authorities a parachute of his invention; and a number were ordered.

In October very strict regulations were issued as to aircraft flying over prohibited areas, a rule that any offenders would be shot at was subsequently modified.

In November a *Donnet-Lerêque* was purchased for the Navy and another ordered at the Whitehead Works, Fiume.

### Army Section.

At the end of 1911 the Army possessed 4 monoplanes and one biplane (a *Lohner*), now available for school work.

During 1912 there were acquired:—

**20 monoplanes.**—1 *Bleriot*, 2 *Nieuport*, 15 *Etrich-Taube*, 1 *Etrich* limousine, 1 *Deperdussin*.

**6 biplanes.**—4 *Lohner-Daimler*, 1 *Mars*, 1 *Klobucar*, (of the above the 2 *Nieuports*, 1 *Etrich* limousine and the 4 *Lohners* were the only ones built in Austria).

### Naval Section.

**4 hydro-avions** were acquired during 1912; 2 *Donnet-Levêque* and 2 *Paulhan-Curtiss*.

### Military Pilots.

Banfield, Ob. Leut.  
Blaschke, v. Ob. Leut.  
Eyb, Ob. Leut.  
Flassig, Leut.  
Holeka, Ob. Leut.  
Kenese, Ob. Leut.  
Klobucar, Ob. Leut.  
Miller, Ob. Leut. (5)  
Oelwein, Ob. Leut.  
Perini, Leut.  
Petroczy, Haupt. von.  
Riedlinger, Ob. Leut. von.  
Schindler, Leut.  
Schünzel, Leut.  
Stohanzl, Ob. Leut. K (14)  
Umlauff, Major von. (10)  
Uzelac, Ob. Leut.  
Venczel, Leut.  
Welhelm, Ob. Leut. von

The military centre is at Goerz, the naval one at Pola.

Flying officers receive each a grant of 1,600 crowns; also 15 crowns a month for upkeep. Special certificate brings 2,000 crowns extra grant.

### Private Aviators.

\* = Superior brevet.  
+ = Killed.

Auer, J. (6)  
Baar, R.

Baboncse, K.  
Banfield, K.  
Bauer, Dr. V.R. von.  
Bernat, M.  
\*Brier, H. (18)  
Blaschke von. Z.R.  
Booms, W. (9)  
Bratmann, J.  
Buchstätter, A.  
Cejnek, J.  
Cihak, E.  
Ciszek, J.  
Czermak, J.  
Dworak, W.  
\*Economo, C.F. von. (7)  
Fiedler, P. (19)  
\*Flesch, J. (11)  
Friedmann, W.  
Haner, E.  
Hesse, M.  
Heyrowski, A.  
Hieronimus, O.  
Hinter, K.  
Hold, Hermann  
Huss, H.  
\*Illner, K.  
Javor, J.  
Kaiserfeld, R. von.  
Kasulakow, W.  
Keck, Z.  
Kenese, W.  
Király, K.  
Klobucar, V.  
Knirsch, A.  
Kolowrat, A. Graf. (15)  
Kreiner, E.  
Lagler, B.V.  
Latzel, J.  
Lettis, A.  
Libowitzky, A.  
Mandl.  
Mazuranic, B.  
+Mosen.  
Nemec, H.E. von.

Nittner, E.  
Ockermüller, H.  
+Petrovics, A. von. (13)  
Pischof. A.R. von. (2)  
Rabis, M.  
Reisner, H.  
Riedlinger, E. v. Kastrenberg.  
Rosenthal, F.  
+Russjan.  
Sablatnig, J. (12)  
Schartner, H.  
Schindler, A.  
Schonowsky, B.  
Schönpflug, F.  
Seidl, Franz.  
Simon, R. (4)  
Stanger, R.  
Steiner-Görtl, E. v. A.  
Stiploschek, M.  
\*Székely, M.  
Tauszig, A.  
Teufl von. Ferland, R.  
Umlauff von F.  
Vlaicu, A.  
\*Warchalowski, A. (1)  
Warchalowski, K. (8)  
Weiner, T.  
Widmer, J.  
+Wiesenbach, V.  
Woseček, W.

### **Private Aeroplanes.**

At the end of March, 1913, the total number of private aeroplanes in the country was about twenty.

## ETRICH Monoplanes.

Etrich Flieger Werke, Wiener Neustadt. Igo Etrich was a very early experimenter in conjunction with Wels. In 1909 he produced on his own account the first *Etrich* monoplane, a characteristic machine, which except for detail improvement, varying dimensions, etc., has not been appreciably altered since. (See Historical Section.)



Photo, C. Malcuit.

Model and date.		VII 1911.	VIII 1911-12. 2-seater	1912-13. Limousine 2-seater.
Length	feet (m.)	37 (11.30)	30¾ (9.30)	26¼ (8)
Span	feet (m.)	48 (14.60)	42 (12.80)	31¼ (9.50)
Area	sq. feet (m <sup>2</sup> .)	380 (35)	323 (30)	280 (26)
Weight	total lbs. (kgs.)	...	...	...
	useful lbs. (kgs.)	...	...	...
Motor	h.p.	120 Daimler	100	60 Daimler
Speed	m.p.h. (km.)	...	...	...
Number built during 1912		5	2	2

*Remarks.*—A number of VII & VIII have been sold for military purposes to the Austrian, Russian, German, and other governments.

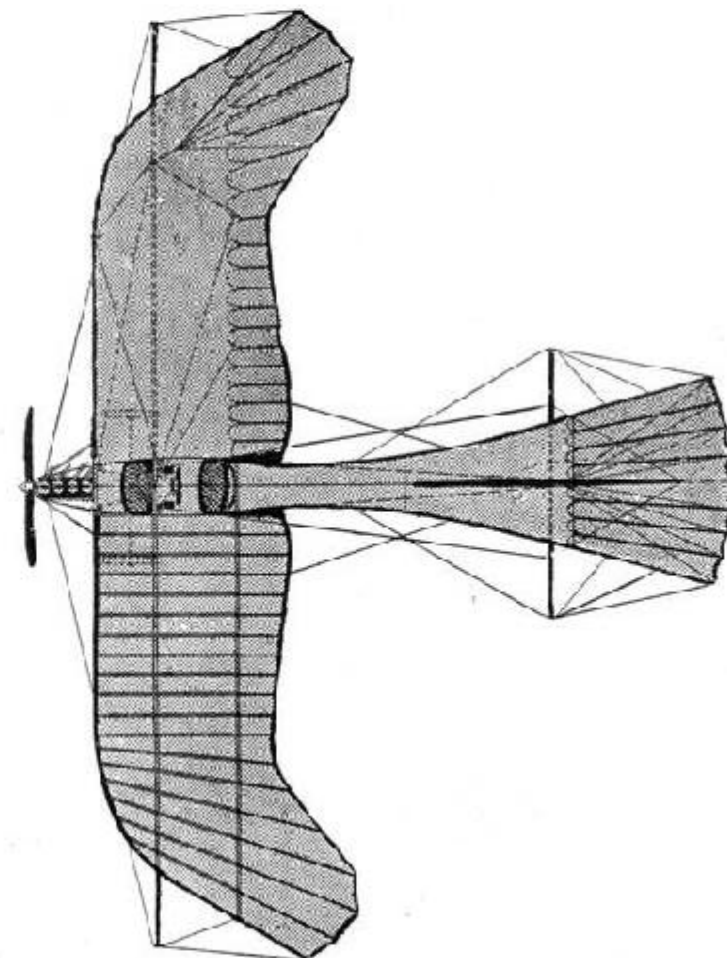
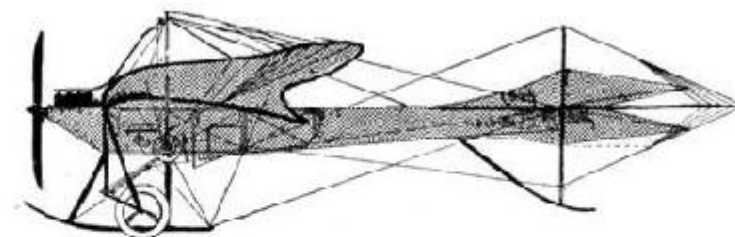

Uniform Aeroplane Scale

Etrich VIII.



Etrich. Limousine.

Photo, Guld.

### LOHNER-DAIMLER.

This firm is now amalgamated with Etrich.



	1911.	1912-13. Lohner Daimler Pfeilflieger.
Length	feet (m.)	...
Span	feet (m.)	...
Area	sq. feet (m <sup>2</sup> .)	...
Weight	total lbs. (kgs.)	...
	useful lbs.(kgs.)	...
Motor	h.p.	60 Aust. Daimler
Speed	m.p.h. (km.)	50 (80)
Number built during 1912	?	4

*Remarks.*—Staggered and V shape. Late in 1911 one was purchased for the Austrian Army. In 1912 made a world's altitude. Passenger record, 4,530 metres (14,862 feet.)

### MERCEP Monoplanes.

Mihalis Mercep, Aeroplanwerkstatte, Agram, Hungary. Russjan was connected with this firm, which built 2 biplanes to his designs in 1909. Russjan was killed in the second of these. In 1911, a *Mercep* was built.

	1911.	1912-13.
Length	feet (m.)	29½ (9)
Span	feet (m.)	34-1/3 (10.50)
Area	sq. feet (m <sup>2</sup> )	...
Weight	machine, etc. lbs. (kgs.)	...
	useful lbs. (kgs.)	...
Motor	h.p.	50 Gnome
Number built	1	1

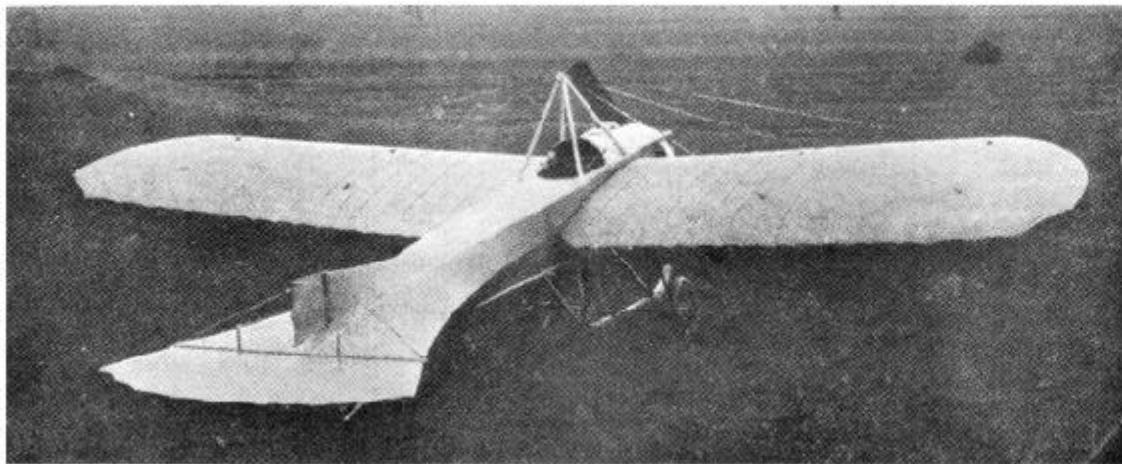

Mercep. 1912-13.

## ZIEGLER Monoplane.

Flugzeugwerke Johann Ziegler, Vienna.

		1912-13.
Length	feet (m.)	59 (18)
Span	feet (m.)	42¾ (13)
Area	sq. feet (m <sup>2</sup> .)	586 (55)
Weight	total	1656 (750)
	useful	...
Motor	h.p.	100 Mercedes
Speed	m.p.h. (k.m.)	50 (80)
Number built during 1912		2

## WARHALOWSKI, Biplane.

Karl Warchalowski, Autoplan Werke, Odoakergasse 35, Vienna XVI.

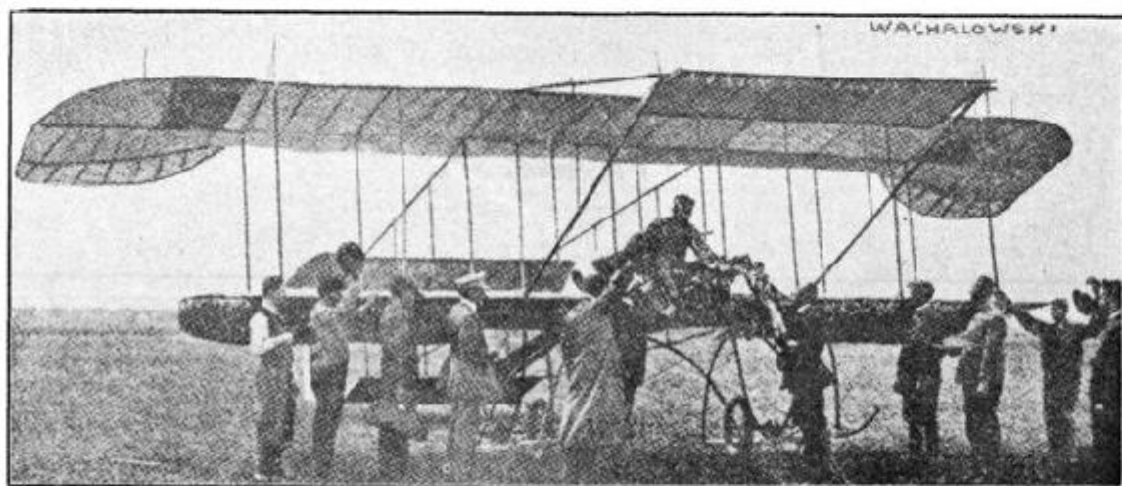

A machine generally on *M. Farman* lines, but with different shaped ailerons and corners of the leading edge rounded.

## WHITEHEAD.

Whitehead & Co., Fiume, Austria. The Whitehead Torpedo Co. has laid down plant for the production of hydro-aeroplanes.

## AUSTRO-HUNGARIAN DIRIGIBLES.

### Military.

Date of order.	Name.	Make.	Type.	Capacity in m <sup>3</sup> .	H.P.	Speed. m.p.h. (k.p.h.)	Remarks.
1909	M 1	Parseval P.L. 4	n.r.	2300	70	27 (45)	
1909	M 2	Lebaudy-Juillot 6	s.r.	4800	100	23 (37)	Wrecked 1911 but repaired
1910	M 3	Körting (K.W. 1)	n.r.	3600	150	30½ (49)	
1912	M 4	Zeppelin		22,000	450	47 (75)	Building.

### Military Dirigible Pilots.

Cajanek, V.  
 Grebenz, K.  
 Hauswirth, J.  
 Heller, S.  
 Hofstätter, E.  
 Macher, M.  
 Tauber, F.  
 Tepser, G.E. von.  
 Weiss, H.

### Private.

Date of commencement.	Name.	Make.	Type.	Capacity in m <sup>3</sup> .	H.P.	Speed m.p.h. (k.p.h.)	Remarks.
1910	MANNSBARTH-STAGL	Mann-Sl.	n.r.	8200	300	40 (65)	
1912	BOEMCHER II	Boemcher II		2750		25 (40)	

Two *Renners* and a *Boemcher I* have ceased to exist.

Private Dirigible Pilots.

Adrario, K.  
 Baumann, F.  
 Becker, T.  
 Berlepsch, F.F. von.  
 Cassinone, A.  
 Fürst, A.  
 Hoffory, W.  
 Hinterstoisser, F.  
 Kaiser, K.  
 Mannsbarth, F.  
 Nowy, V.  
 Richter, von. B.  
 Stigel, H.  
 Stratmann, W.  
 Wagner, E. von. F.  
 Zborowski, J.

### BOEMCHER II. (1912-13.) Non-rigid.

Building.

**Length**, ? feet (? m.) **diameter**, ? feet (? m.) **volume**, 77,000 c. feet (2,750 m<sup>3</sup>.)

**Gas bags.**—

**Motor.**—

**Speed.**—25 m.p.h. (40 k.p.h.)

**Propeller.**—



**LEBAUDY-JUILLOT 6=Military M II. (1910.) Semi-rigid.**

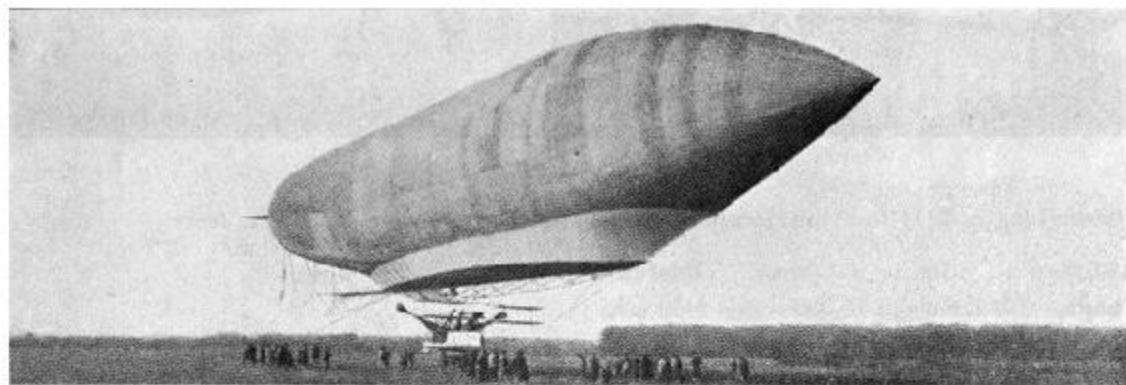

**Length**, 229¾ feet (10 m.) **diameter**, 36 feet (11 m.) **volume**, 170,000 c. feet (4,800 m<sup>3</sup>.)

**Gas bags.**—Austro-American Rubber Co.

**Motor.**—100 h.p. Mercedes.

**Speed.**—27 m.p.h. (45 km.)

**Propellers.**—Two 2-bladed.

**Remarks.**—Built by the Austrian Daimler works to *Lebaudy-J.* designs. Sister to the Russian *Lebed.*

**KÖRTING-WIMPASSING (K-WI). Non-rigid=Military. M III. (1911.)**

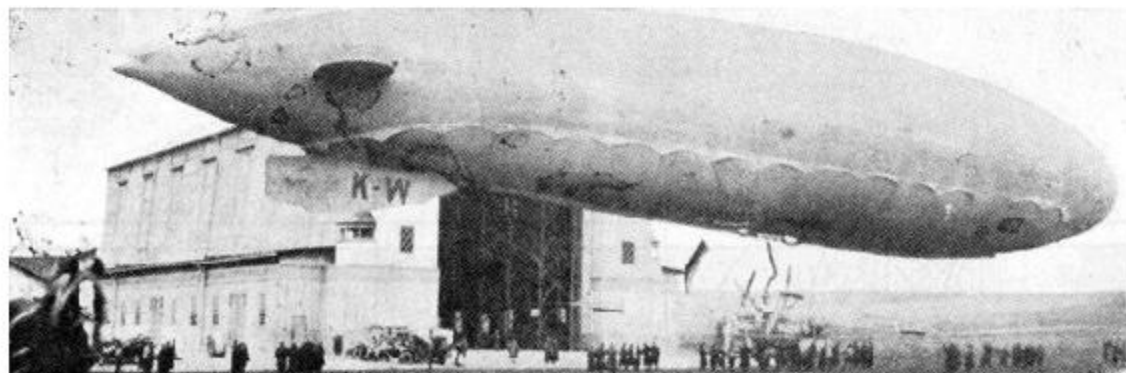

**Maximum length**, 213¾ feet (65 m.) **maximum diameter**, 34½ feet (10.50 m.) **volume**, 127,150 c. feet (3,600 m<sup>3</sup>.)

**Total lift.**— lbs. ( kgs.) **Useful lift**, lbs. ( kgs.)

**Gas bags.**—2 ballonets of 15,900 c. feet (450 m<sup>3</sup>.)

**Motors.**—2 Körting, of 75 h.p. each (= 150 h.p.)

**Speed.**—30½ m.p.h. (49 km.) Made on trials March, 1911.

**Propellers.**—Two 4-bladed. Diameter, 9¾ feet (3 m.)

**Steering.**—*Parseval* style. This ship is generally an adaptation of the *Parseval* type. Accommodates 8 people. Completed 1911. Military airship.

**Remarks.**—

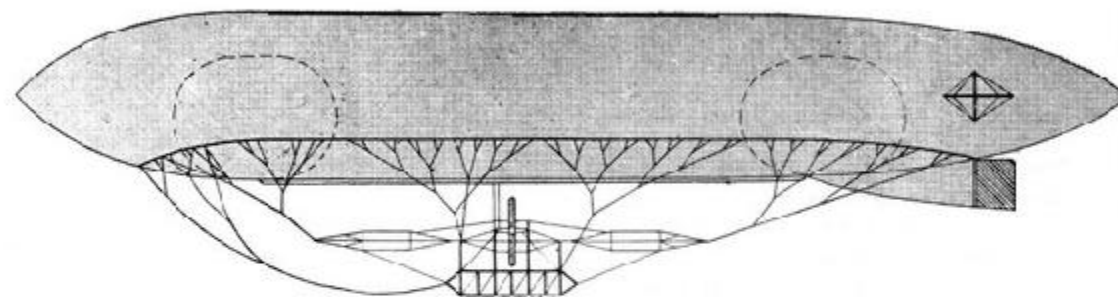

Uniform Dirigible Scale.

**MANNSBARTH. Non-rigid (1911).  
(Alias STAGL MANNSBARTH.)**



**Maximum length**, ? feet (? m.) **maximum diameter**, ? feet (? m.) **volume**, 289,600 c. feet (8,200 m<sup>3</sup>.)

**Total lift.**— lbs. ( kgs.) **Useful lift**, lbs. ( kgs.)

**Gas bags.**—Divided into 4 compartments. Ballonet in each.

**Motors.**—2 of 150 h.p. each (= 300 h.p.)

**Speed.**—40 m.p.h. (65 k.p.h.)

**Propellers.**—3. Diameter, 13 feet (4 m.) Also 1 helice.

**Steering.**—Helice used as elevator. Rudder aft. Forward and after ballonets also used as elevators, *Parseval* style. Completed 1911.

**Remarks.**—Built for Government, but not taken over.

#### PARSEVAL P.L. 4. Non-rigid. = MILITARY M I. (1909.)

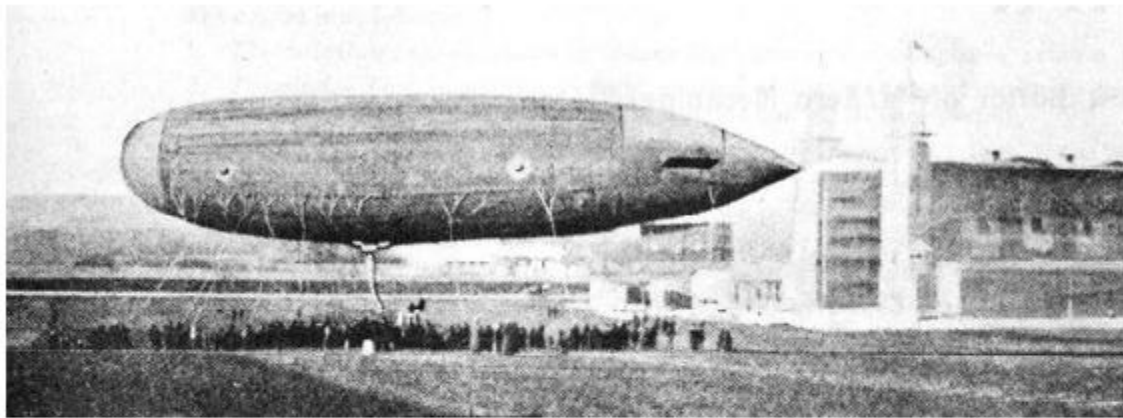

**Maximum length,** 164 feet (50 m.) **approx. diameter,** 28¼ feet (8.60 m.) **volume,** ? c. feet (2,300 m<sup>3</sup>.)

**Total lift.**—5,730 lbs. (2,600 kgs.)

**Gas bags.**—Rubbered fabric by Austrian American Rubber Co.

**Motor.**—70-100 h.p. Mercedes Daimler. 1,200 r.p.m. at 70 h.p.

**Speed.**—27 m.p.h. (45 km.) made on trials.

**Propellers.**—*Parseval* type, semi-rigid, chain driven, 3-bladed. Diameter, 11½ feet (3.50 m.)

**Steering.**—*Parseval* system.

**Remarks.**—Built by the Austrian Motorluftschiff Gesellschaft to the *Parseval* type C design (see Germany). Taken over by the Austro-Hungarian Army, December, 1909. Has flown 6½ hours. Has risen to 1,150 metres and subsequently flown 1½ hours. Carries 4 persons, *about* 400 lbs. (180 kgs.) ballast, and fuel for 12 hours. *Station:* Fischamend.

## BELGIAN.

(Revised by M. BRACKE, Aeronautical Engineer & Editor of "L'Aero Mécanique.")

#### Aerial Societies:—

Aero Club Belgique.  
Aero Club of Hainault.  
La Ligue Nationale Belgique.  
Delta Club (Kites).  
Ae. C. de Flanders.  
Ae. C. du Littoral.  
Ae. C. de Liege-Spa.

#### Aerial Journals:—

*La Conquête de l'Air.* (214 Rue Royale, Brussels) bimonthly, 5 francs p.a.  
*L'Aero Mécanique* (Brussels edition). Chemin de St. Denis, Casteau, Mons., Belgium, 2.50 f.  
*L'Aviation Industrielle et Commerciale* (monthly), Chemin de St. Denis, Casteau, Mons., 1.50 f.

#### Flying Grounds:—

Berchem.  
Brasschaet (Military).  
Camp de Casteau. (Aviation Industrielle & Commerciale).  
Etterbeek, near Brussels.  
Kiewit.  
St. Job (private property Baron de Caters.).

## BELGIAN AEROPLANES.

#### Military Aeroplanes.

At the end of 1912 the military air force consisted of three 50 h.p. Gnome H. Farman 1911 military, used for instructional purposes, and twenty-four 70 h.p. Gnome H. Farmans (model 1912 military), for war work:

The military school is at Brasschaet, near Antwerp. Major Campion in command.

The course is as follows:

1. *Theoretical course*.—Lectures on meteorology, structure of aeroplanes, aviation motors, etc.

2. *Practical*.—This, in addition to flight, consists of dismantling and replacing parts of aeroplanes and aerial motors, all general repairs, erecting hangars and aerial photography.

The school possesses nine hangars, of which three are Bessonneau type, three wooden, and three metal.

For 1913 the sum of £20,000 is to be expended for purchase of aeroplanes and the establishment of aerial squadrons at Antwerp, Liege, and Brasschaet.

These are organised into six squadrons of four units each. The full complement of each squadron is eight aviators, fifteen to 20 mechanics, etc., and six citizen soldiers.

The question of hydro-avions for the Congo is under consideration.

## AVIATORS.

(The number against any name is, unless otherwise stated, the Ae. C. Belgique pilot certificate number.)

### Military.

Broune, Lieut. (37)  
Cozic, R. (23)  
Dhanis, Lieut. (35)  
Heinter Poorten (47)  
Lebon, Lieut. (36)  
Moulin, E. (45)  
Movtens, Lieut. (19)  
Nelis, Lieut, (in command) (28)  
Robert, V. (47)  
Sarteel, Lieut. (26)  
Sournoy, J. (46)  
Tocy, Lieut.

### Private.

Allard, E. (4)  
Armand, C. (22)  
Baugniet, Edmond (18)  
Boel  
Bracke, A.

Camille, Amand (22)  
Christiaens, Joseph (7)  
Crombez (25)  
De Caters, Baron (1)  
De Heel, Emile (24)  
D'Hespel, Comte Joseph (15)  
De la Hault, Adhemar  
De Laet, E. (31)  
De Laminne, Chev (9)  
De Jonckeer (44)  
Depireux, Isidore (20)  
De Petrovsky, Alexandre (11)  
De Ridder, Alphonse (13)  
De Roy, W. (41)  
Descommines  
Deudeuner, A. (43)  
Dolphyn (40)  
Doneryos, J. (33)  
Duray, A. (3)  
Dutrieu, Mdlle. H. (27)  
Fischer, Jules (12)  
Frenay, Fernand (21)  
Hanciau, P. (34)  
Hanouilleo, P. (42)  
Hasen  
Lamblotte, F. (29)  
Lanser, Alfred (16)  
Lescart, F. (30)  
Mestagh, G. (39)  
Michez, S.R. (32)  
Olieslagers, Jan (5)  
Olieslagers, Max  
Orta, José  
Peeters  
Pickard  
Stellingwerff, J. (49)  
Tyck, Jules (8)  
Van den Born, Chas. (6)  
Verschaeve, Fernand (17)  
Verstraeten, Léon (14)

The following Belgian aviators have been killed:—

Kinet, Daniel (2)  
Kinet, Nicolas (10)

**BEHUEGHE**

(Bron), in Herseun. Built in 1912. A monoplane that flew very well at camp of Casteau Aerodrome during May—October. **Motor.**—25. h.p. type Morane. New designs in wing construction, landing chassis, etc.

**A. BRACKE**

(formerly Bracke, Missyon & Co.), Casteau, Mons. In 1910, constructed the first aeroplane built by a Belgium firm—a monoplane with planes at 120. This machine has not been duplicated: but the firm have since built machines to private specifications. The only firm which has in Belgium the speciality of aeronautical patents.

**DE BROUCKERE,**

23 rue Joardens, Brussels. Biplane. H. Farman. type. Built in 1911, modified in 1912.

**DE LA HAULT**

Adhémar de la Hault, 214 rue Royale, Brussels. In 1906, built a flapper of novel design. This was followed in 1910, by a machine on monoplane lines with one fixed plane and two flapping wings. This failed to fly, and in August, 1911, was altered into a biplane. It did not succeed, however. M. Hault is still pursuing the ornithopter question.

**HAREL I. Biplane.**

**Length.**—49¼ feet (15 m.) **Surface.**—344½ sq. feet (32 m<sup>2</sup>.) **Weight.**—771 lbs. (350 kgs.), flying order. Warping wings. Monoplane tail. **Motor.**—50 h.p. Gnome, mounted just under and forward of the upper wing. **Tractor.**—1 Chauviere. Elevator placed 1 in front and 1 in rear, *H. Farman* style. Rudders, 2 in rear. Completed May, 1911. For further details see *Conquete de l'Air*, July 1st, 1911. Property of M. Van der Stegen.

**WILLIAMS. Biplane.**

**Motor.**—70 h.p. E.N.V. Generally of headless *Voisin* type on a *Farman* body. Completed 1911. Has flown fairly well.

**Military.**

1910.

1. *LA BELGIQUE II (late I)* 4,000 m<sup>3</sup>.

1911.

2. *LA BELGIQUE III*

*Note.*—*La Belgique I* was built in 1909 and re-built 1910.

**Private.**

- VILLE DE BRUXELLES* 6,000 m<sup>3</sup>.

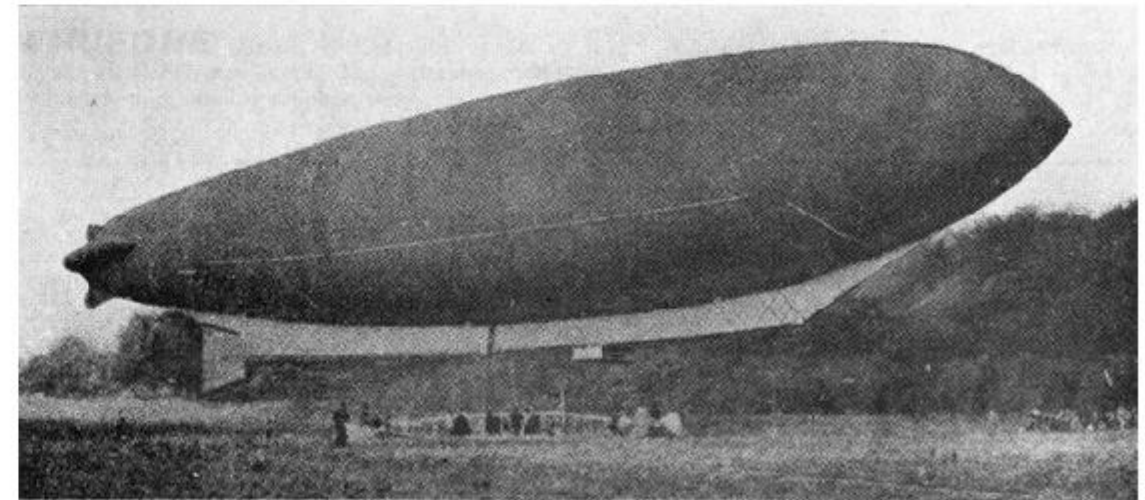
**LA BELGIQUE II. (No. 1 rebuilt.) Military.**

**Length,** 226 feet (64.8 m.) **maximum diameter,** 35 feet (10.75 m.) **capacity,** 141,300 cubic feet (4,000 m<sup>3</sup>.) **total lift,** 9,921 lbs. (4,500 kgs.)

**Gas bag.**—Rubber proofed Continental fabric. Ballonet, filled by a separate motor giving 7.5 inches of water pressure. Warm air can be pumped in if required. Ballonet, 28,250 c. feet (800 m<sup>3</sup>.)

**Motors.**—2, each of 60 h.p., Vivinus, 4-cylinder, 112×130.

**Propellers.**—1 in front of the car. 285 revolutions per minute. Wood construction.

**Speed.**—25 miles per hour. 40 km. per hour.

**Planes.**—Horizontal: a gas tube bent horizontally round the tail. Vertical: vertical fins on the tail, and a long vertical keel under the gas bag.

**Car.**—A girder, square in section, tapered at both ends. Built of tubular steel. Length, 82 feet (25 m.)

**Miscellaneous.**—Built by L. Godard, France, 1909. Crew, 3 men. Accommodation for 1 passenger. Fuel for 10 hours. Greatest height attainable, 3,280 feet (1,000 m.)

**Table of weights.**—

	lbs.	kgs.
Gas bag, complete with ballonet, valves, planes,		
suspension, etc	1,951	885
Propellers (2)	275½	125
Blower	33	15
3 h.p. motor for blower	33	15
Motors (2) complete with gearing and shafting	1,410	640
Car	992	450
Fuel for 10 hours	738½	335
Ballast	826¾	375
1 passenger (or ballast)	154	70
Crew (3)	463	210
Guide ropes, etc	220	100
Miscellaneous	88	40
	<i>About</i> 7,165	3,250

**Remarks.**—Reconstructed in the winter of 1909. There are two noteworthy innovations in connection with the ballonet. (1) The ballonet can be warmed by the motor. (2) In case of real emergency air can be pumped direct into the gas bag. Experiments of the utmost importance to all airships are in progress with a view to ridding the gas of this air cheaply and quickly.

**LA BELGIQUE III. Military.**

Presented 1910 to the Belgian Government by H.M. the King of the Belgians. 4,500 m<sup>3</sup>. Practically same as II, but has 3 propellers. **Motors.**—Two 100 h.p. Germain.

**VILLE DE BRUXELLES.**

(Formerly known as LA FLANDRE.)

(Astra type.)

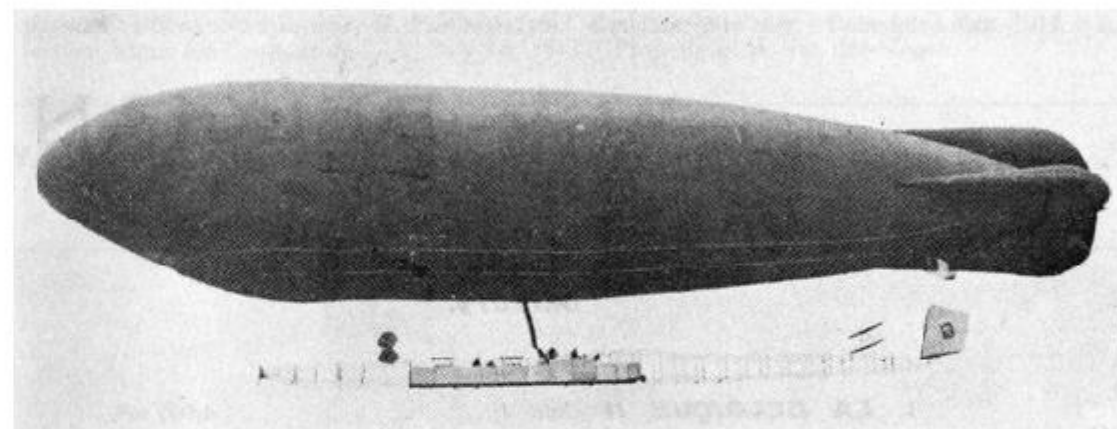

**Maximum length,** 256 feet (78 m.) **maximum diameter,** 41 feet (12.4 m.) **volume,** 212,000 c. feet (6,000 m<sup>3</sup>.)

**Total lift.**—15,763 lbs. (7,150 kgs.) **Useful lift,** ? lbs. ( ? kgs.)

**Gas bags.**—Continental rubbered fabric, yellow. Ballonet, 16,146 c. feet (1,500 m<sup>3</sup>.)

**Motors.**—2 Pipe motors of 100 h.p. each, placed in line with each other in the fore and aft line, and with clutches and the necessary gearing in between them.

**Speed.**—35 m.p.h.

**Propellers.**—3, namely: one at the fore end, driven by the two motors when coupled together, and two placed above and on either side of the centre of the car, for use when only one motor is running. Chauvière propellers.

**Steering.**—Vertical steering by means of a large double aeroplane fixed above the car, about a third from the front. Horizontal steering by means of a double vertical rudder above the rear end of the car. Stability is secured by the usual Astra pear shaped stabilising gas bags, with fins of rubbered cloth spread between the inner edges of these shapes.

*Remarks.*—The distinctive feature of this ship is the arrangement of the propellers. Both motors can be coupled either on to the front propeller or on to the two rear propellers, or on to all three together, but they are actually intended only to drive the front one. On stopping either motor the other is connected to the two rear propellers, which are designed for a slower speed of translation than the front one, with the result that the running motor does not find itself overloaded as it would if the same propeller had to serve both for one and for two motors.

## BRAZILIAN.

### AVIATORS.

Garos, Queiroz, Robert, Henri, Santos-Dumont, Versepuiz.

There are possibly one to two aeroplanes in Brazil, but the well-known aviators live in France. Little or nothing seems doing in Brazil as yet.

## BRITISH.

### Aerial Societies:—

Royal Aero Club.  
Aerial League.  
Aeronautical Society. (Premier Society, founded 1866.)  
Brooklands Aero Club.

There were once a great many local aero clubs, but the majority of these have ceased to exist and with one or two possible exceptions all the rest are moribund.

### Aerial Journals, etc.:—

*Aeronautical Journal.* Quarterly. 53, Victoria St., London, S.W.  
*Aeronautics.* 3d. monthly. 27, Chancery Lane, London, W.C.  
*The Aero.* 6d. monthly. 20, Tudor St., London, E.C.  
*Flight.* 3d. every Saturday. 44, St. Martins Lane, London, W.C. (Official organ of the R. Ae. C.)  
*The Aeroplane.* 1d. weekly, 166, Piccadilly, London.  
*All the World's Aircraft.* 21/- Annual. 100, Southwark Street, London, S.E. and 5, Queen Victoria Street, London, E.C.

In addition, the *Car Illustrated* and the *Motor* devote considerable space to aerial matters.

### Principal Flying Grounds:—

**Aldershot.**—Army school.

**Brighton,** Shoreham Aerodrome. Aero school.

**Brooklands.**—Bristol school.

**Camber Sands,** Rye, Sussex.—At low tide moderately hard sand and soft places. Area two miles by one mile.

**Dagenham** (Aeronautical Society).

**Dartford Marsh.**—Vickers school.

**Dunstall Park,** Wolverhampton.

**Eastbourne.** Aerodrome School.

**Eastchurch,** Sheppey.—(R. Ae. C.) 350 acres. Sheds. Members only. R. Naval school.

**Filey.**—Blackburn school.

**Hendon.**—Grahame-White, Blackburn, Bleriot, Deperdussin, Temple and Ewen schools.

**Lanark.**—Deperdussin school.

**Liverpool** (Melly school).

**Llandudno & North Wales.**—Aerodrome.

**Mapplin Sands,** Essex.—(Foulness). Very hard sand at low tide. Area ten miles by four miles. Property of War Office. Flying forbidden in winter.

**Salisbury Plain.**—Bristol school. Vast space available. Plenty of fairly smooth ground. Army school.

**Shoreham.**—(See Brighton).

**Upavon.** Central flying school (R. Flying Corps.)

## BRITISH MILITARY AVIATION.

### Royal Flying Corps.

In 1912 the Royal Flying Corps was instituted. It consists of two wings, navy and army, with a central flying school at Upavon, Salisbury Plain.

The staff is as follows:—

*Commandant:* Paine, Capt. G.M., M.V.O., R.N.

*Secretary:* Lidderdale, Asst. Paymaster J.H., R.N.

*Medical Officer:* Lithgow, Capt. E.G.R., R.A.M.C.

*Quarter-Master:* Kirby, Hon. Lieut. (Qr.-Mr.), V.C.

*Instructor in Theory and Construction:* Cook, Lieut.-Col. H. R., R.A.

*Instructor in Meteorology:* Dobson, G., Esq.

*Instructors in Flying:*

Fulton, Capt. J. D. B., R.A.

Gerrard, Capt. E. L., R.M.

Shepherd, Lieut. P. A., R.N.

Trenchard, Mt. Maj. H. M., D.S.O., R. Sc. Fus.

Salmond, Capt. J. M., R. Lanc. R.  
*Inspector of Engines*: Randall, Eng.-Lieut. C. R. J., R.N.

### Royal Aircraft Factory.

This is situated at Farnborough. Mervyn O'Gorman is superintendent. There are large sheds. Some *B E* biplanes have been built here, but the principal object of the factory is understood to be repairs and maintenance.

### Naval Wing Royal Flying Corps, Aeroplane Section.

There is a special Air Department at the Admiralty with Captain M. F. Sueter, as Director, Commander O. Schwann and Lieut. C. L'Estrange-Malone, as Assistants, Eng. Lieut. G. W. S. Aldwell, as Eng. Inspector.

Officers are graded Flying Officers, then Flight Commanders, thence to Squadron Commanders.

The flying school is at Eastchurch, Sheppey. Commander Sampson, S.C., in command. There are at present four air stations: (1) Isle of Grain, (2) Calshot, (3) Harwich, (4) Yarmouth.

At the end of March, 1913, the total number of aeroplanes including those on order, school machines, etc., was about 32; of which about 16 were effective for war purposes or available at short notice.

These machines were as follows:—

**7 monoplanes** ( = 1 *Bleriot*, 2 *Deperdussin*, 1 *Etrich*, 1 *Nieuport*, 2 *Short*).

**15 biplanes** ( = 1 *Avro*, 2 *Bristol*, 1 *Breguet*, 1 *Caudron*, 2 *H. Farman*, 1 *M. Farman*, 5 *Short*, 2 *Sopwith*).

**10 hydro-avions** ( = 1 *Astra*, 1 *Avro*, 2 *Borel*, 1 *Donnet-Leveque*, 1 *H. Farman*, 1 *M. Farman*, 3 *Short*).

The *personnel* is as follows (number after names is the R. Ae. C. brevet number):—

### Squadron Commanders.

Gerrard, Capt. F. L., R. M. (76)  
Gordon, Capt., R. M. (161)  
Gregory, Lieut. (75)  
L'Estrange-Malone, Lieut. C. (195)  
Longmore, Lieut.  
Sampson, Com. C. R. (71)

Shepherd, Lieut. P. A. (215)

### Flight Commanders.

Courtney, Lieut. I. T. (R. M.)  
Grey, Lieut. Spencer (117)  
Risk, Capt. C. E., R. M. (303)  
Seddon, Lieut. J. W. (296)

### Flying Officers.

Those marked \* are under instruction, not yet graded.

\*Agar, Lieut. A.W.S.  
Babington, Lieut. J.T. (408)  
Bigsworth, Lieut. A.W. (390)  
\*Bobbett, Boatswain H.C. (334)  
Bowhill, Lieut. F.W. (397)  
\*Brodrigg, Lieut. F.G. (481)  
Courtney, Lieut. I.T., R.M.  
Courtney, Lieut. C.L. (328)  
\*Davies, Lieut. R.B. (90)

\*Edmonds, Lieut. G.H.K.  
 \*Fawcett, Capt. H., R.M.  
 \*Gaskell, Lieut. A.B.  
 \*Hathorn, Lieut. G.H.V., R.M.  
 Hewlett, Sub. Lieut., F.E.J.  
 Kennedy, Lieut. J.B.  
 \*Maude, Lieut. C.E.  
 \*Noyes, Asst. Paymaster, C.R.F.  
 Oliver, Lieut. E.A. (425)  
 \*Parker, Asst. Paymaster E.B. (415)  
 Rathbone, Lieut., C.E., R.M.  
 Ross, Lieut. R.P. (422)  
 \*Sitwell, Lieut. W.G.  
 Travers, Lieut. J.L.  
 Vernon, Lieut. H.D. (404)  
 Wildman-Lushington, Lt. G.V., R.M.A.

The following R.N. officers and men are aviators employed in various duties at the Admiralty, at the Central Flying School or at Eastchurch:—

Aldwell, Eng. Lieut. G.W.S.  
 Andrews, J.C. (372)  
 Ashton, Ldg. Seaman  
 Batemad, Able Seaman P.E. (446)  
 Briggs, Eng. Lieut. E.F.  
 Brownridge, Carp.  
 Collins, Art. Eng. J.V.  
 Cresswell, Lieut. T.S., R.M. (420)  
 Deakin, A. (333)  
 Gerrard, Capt., R.M. (76)  
 L'Estrange-Malone, Lieut. C. (195)  
 Lidderdale, Asst. Paymaster H.J. (402)  
 O'Connor, Art. Eng. T. (280)  
 Paine, Capt. G.M. (217)  
 Randall, Eng. Lieut. (81)  
 Schwann, Com. O. (203)  
 Scarff, Art. Eng. F.W.  
 Shaw, Shipwright D. (465)  
 Shepherd, Lieut. P. (288)  
 Susans, F. (380)  
 Wells, Staff. Surg. H.V.

The following have privately secured pilot certificates in the years mentioned but are not employed in the R.F.C. for aeroplane work. Some of them, however (D), are employed in the airship section:—

1911.

Bower, Lieut. J.A. (161)  
 Clark-Hall, Lieut. (127)  
 Leveson-Gower, Com.  
 Williamson, Lieut. (150)  
 Williamson, Lieut. H.A. (160)

Naval. 1912.

Blatherwick, Lieut. G. (450)  
 Brown, Com. A M.T. (345)  
 Edwards, Lieut. C.H.H.  
 D Freeman Williams, Lt. F.A.P.(202)  
 Head, Lieut, G.G.W. (191)  
 Hooper, Sub. Lt. C.W.W. (382)  
 Johnson, Capt. C.D.  
 D Masterman, Com. E.A.D. (Ae.C.F.)  
 Prickett, Lieut. C.B. (381)  
 Trewin, Asst. Paymaster (294)  
 D Usborne, Lieut. N.F. (449)  
 Wheeler, Mid. N.F. (370)

Naval. 1913.

D Boothby, Lieut. F.L.M. (Ae.C.F.)  
 Brady, B.J.W. (394)  
 Brown, Lieut. A.C.G. (398)  
 Dobie, Lieut. W.F.R. (448)  
 Fitzmaurice, Lieut. R. (447)  
 Freeman, S.T. (393)  
 Littleton, Sub. Lieut. H.A. (405)  
 Picton-Warlow, Lieut. W. (451)  
 Ross, Lieut. R.P. (422)

### **Army Wing Royal Flying Corps, Aeroplane Section.**

The Army wing has its headquarters at S. Farnborough, its constitution being as follows:—

1st squadron (airships or kites) see Dirigible Section.  
 2nd squadron (aeroplanes) base at Montrose.  
 3rd squadron (aeroplanes) base at Salisbury Plain.  
 4th squadron (aeroplanes) base at S. Farnborough.



(Four more aeroplane squadrons *pro.*)

An aeroplane squadron nominally consists of 18 aeroplanes (9 in service, 9 remounts). At the end of March, 1913, the total number of aeroplanes, including those on order, school machines, etc., was about 110, of which about 50 (including some monoplanes not in use) were effective for war purposes or available at short notice.

The total of 110 was thus made up:—

**22 monoplanes** (= 2 *Bleriot*, 4 *Bristol*, 5 *Deperdussin*, 4 *Howard-Flanders*, 1 *Martinsyde*, 6 *Nieuport*).

**86 biplanes** (= 4 *Avro*, 22 *B.E.* type, <sup>[A]</sup> various makers), 2 *Breguet*, 2 *Caudrons*, 30 *Farman* (various types),  
6 *Short*—and about 20 *Avro* or *Farman* or *Short* not delivered.

### Squadron Commanders.

Brooke-Popham, Capt. H.R.M. (108)  
Burke, Capt. C.J. (46) (Ae.C.F. 260)  
Carden, Lt. A. D. (239)  
Cook, Lt.-Col. H. R. (42)  
Fulton, Major J. D. B. (27)  
Raleigh, Capt. G. H. (196)  
Trenchard, Major H. M. (270)

### Flight Commanders.

Allen, Capt. C. R. W. (159)  
Beor, Lt. B. R. W. (R.A.) (185)  
Becke, Capt. J. H. W. (236)  
Connor, Lt. D. G. (54)  
Fox, Lt. A. G. (176)  
Higgins, Major J. F. A. (R.A.) (264)  
Longcroft, Lt. C. A. H. (192)  
Reynolds, Lt. H. R. P. (R.E.)  
Salmond, Capt. J. M.  
Webb-Bowen, Capt. T. I. (242)

### Flying Officers.

Abercromby, 2nd Lt. R. O. (134)  
Allen, Lt. D. L. (318)

Anderson, Lt. E. V. (247)  
Atkinson, Lt. K. P. (267)  
Barrington-Kennett, Lt. B. H. (Adjutant) (43)  
Beatty, Capt. W. D. (89)  
\*Birch, Lt. W. C. K. (375)  
Board, Capt. A. G. S. (36)  
Boyle, Lt. the Hon. D. G.  
Burchardt-Ashton, Lt. A. E.  
Burroughs, Lt. J. E. G.  
Carmichael, Lt. G. I. (316)  
\*Chinnery, Lt. E. F. (211)  
Cholmondeley, Lt. R. (271)  
\*Christie, Lt. A. (R.A.) (245)  
Conran, Lt. E. L. (342)  
\*Corbalis, Lt. E. R. L.  
Darbyshire, Capt. C. (257)  
Dawes, Lt. L. (228)  
Dawes, Capt. G. W. P. (17)  
\*Gill, Lt. N. J. (174)  
Glanville, Lt. H. F. (307)  
Gould, 2nd Lt. C. G. S. (282)  
Harvey, Lt. E. G.  
\*Harvey-Kelley, Lt. H. D.  
Herbert, Capt. P. L. W. (244)  
Holt, Lt. A. V. (312)  
Hubbard, 2nd Lt. T. O. B. (202)  
Hynes, Lt. G. B. (R.A.) (40)  
James, Lt. B. T.  
Joubert, de la F. Lt. P. B. (280)  
Lawrence, Lt. W.  
MacDonnell, Capt. H. C. (273)  
MacClean, Lt. A. C. H.  
\*Mapplebeck, Lt. G. W. C. (386)  
Martyn, Lt. R. B.  
Mead, Sergt. J. (475)  
Mellor, Capt. C. (155)  
\*Mills, Lt. R. P. (377)  
Moss, Bt.-Major L. B. (241)  
\*Musgrave, Capt. H. (R.E.)  
\*Mulcahy-Morgan, Lt. T. W.  
\*Noel, Lt. M. W. (416)  
Pepper, Lt. J. W. (98)  
\*Picton-Warlow, Lt. W. (451)  
Playfair, 2nd Lt. P. H. L. (283)

\*Pretyma, Lt. G. F. (341)  
Porter, Lt. G. T. (R.A.) (169)  
Pryce, Hon. Lt. W. J. D. (Qr.-mr.)  
\*Read, Lt. A. M. (336)  
\*Rodwell, Lt. R. M.  
Roupell, 2nd Lt N. S. (237)  
Shepherd, Capt. G. S. (215)  
Soames, Lt. A. H. L.  
Small, Lt. F. G. D. (429)  
\*Small, Lt. R. G. (343)  
Smith-Barry, 2nd Lt. R. R. (161)  
Stopford. Lt. G. B.  
\*Todd, Lt. E. (185)  
Thompson, Lt. A. B.  
Tucker, Capt. F. St. G.  
\*Vaughan, 2nd Lt. R. M.  
Wadham, 2nd Lt. V. H. N. (243)  
Waldron, Lt. F. F. (260)  
Wanklyn, Lt. F. A. (284)

### **Reserve.**

Ashmore, Major E. B. (281)  
Bell, 2nd Lt. C. G. (100)  
De Havilland, 2nd Lt. G. (53)  
Hartree. 2nd Lt. A. (214)  
Henderson, Col. D. (118)  
Marks, Lt. C. H. (83)  
Pizey, 2nd Lt. C. P. (61)  
Salmond, Capt. W. G. H.  
Smith, Lt. S. C. W.  
Unwin, Lt. E. F.  
Warter, 2nd Lt. H. de V. (107)

### **Special Reserve. (2nd Lieuts. on probation.)**

Biard, H. C., de la F. (218)  
Busteed, H. R. (194)  
Charteris, R. L. (197)  
Cutler, H. D. (189)  
Davies, E. K. (22)  
\*Fuller, E. N. (325)

Fuller, H. C. (Ae. C. F.)  
Gibson. W. E. (129)  
Hammond, J. J. (32)  
Humphreys, G. N. (390)  
Lerwill, F. W. H.  
Metford, L. S. (146)  
Perry, E. W. C. (130)  
Rickards, G. B. (400)  
Sippe, S. V. (172)  
Spratt, N. C. (339)  
Ware, D. C.  
Wilson, C. D. (Ae. C. F. 136)  
\*Wilson, C. W. (329)  
Young, D. G. (207)

The following have qualified privately, R. Ae. C. brevets, but are not at present employed in the Aeroplane Section:—

1910.

Gibb, Lt. (10)  
Snowden Smith, Lt. (29)  
Watkins, Lt. H. E. (25)  
Wood, Capt. H. F. (37)

1911.

Blacker, Lt. (12)  
Cross, Lt. (151)  
Dickson, Capt. (Ae. C. F. 260)  
Harford, Lt. (152)  
Harrison, Capt. (158)  
Hoare, Capt. (126)

Hooper, Lt. (149)  
Hutchinson, Capt. Steele (143)  
Manisty, Lt. G. (135)  
Pitcher, Capt. (125)  
Sebag-Montefiore, Lt. (93)  
Smeaton, Lt.-Col. (115)

Strover, Lt. E. J. (145)

1912.

Agnew, Capt. C. H. (240)  
Alston, Capt. R. C. W. (255)  
Ashton, Lt. A. E. B. (201)  
Bannerman, Major Sir A. (213)  
Boger, Capt. R. (335)  
Borton, Lt. A. E. (170)  
Boyle, Capt. M. (241)  
Brodigan, Lt. F. J. (200)  
Broke-Smith, Capt. D. W. (204)  
Bulkeley, Lt. H. T. (246)  
Carfrae, Lt. G. T. (188)  
Chamier, Capt. J. A. (340)  
Cordner, Capt. R. H. L. (277)  
Ellington, Capt. E. L. (305)  
Empsom, Lt. J. (387)  
Fielding, L. H. C. (212)  
Fletcher, Lt. (229)  
Hanlon, Lt. D. R. (311)  
Jones, Lt. B. T. (230)  
Lewis, Lt. D. (216)  
Mackay, Lt. M. E. (177)  
Mackworth, Lt. J. D. (209)  
Martin-Barry, Lt. (Ae. C. F.)  
McCudden, Capt. J. H. (269)  
Miller, Capt. G. R. (313)  
Murray, Lt. R. G. H. (320)  
Nicholas, Capt. C. P. (266)  
Penn-Gaskell, Lt. L. de C. (308)  
Percival, Lt. D. (226)  
Pollok, Lt. R. V. (379)  
Powell, Capt. D. W. (389)  
Price, Capt. C. L. (299)  
Rawson, Lt. K. (249)  
Reilly, Lt. H. L. (252)  
Ridd, Corporal F. (227)  
Roger, Capt. R. (335)  
Stott, Capt. J. N. J. (373)  
Styles, Lt. F. E. (338)  
Thomas, Staff-Sergt. (276)

Trevenon, Lt. B. J. (230)  
Weeding, Capt. (182)  
Winfield-Smith, Lt. S. G. (187)  
Worthington-Wilmer, Lt. F. M. (254)

1913.

Archer, Lt. R. H. (434)  
Bayly, Lt. C. G. G. (441)  
Bruce, Sergt. W. R. (467)  
Bourke, Lt. U. J. D. (479)  
Cameron, Major N. J. (478)  
Chidson, Lt. M. R. (471)  
Crogan, Lt. F. J. L. (460)  
Harrison, Lt.  
Hawker, Lt. L. G. (435)  
Hordern, Lt. L. C. (440)  
Hosking, Lt. C. G. (472)  
Hunter, Sergt.  
Kemper, Sergt. K. (444)  
Lee, Lt. C. F. (431)  
Maclean, Lt. L. L. (427)  
Marshall, Lt. R. (470)  
McMullern, Lt. J. D. (436)  
Merrick, Major G. C. (484)  
Mitchell, Lt. W. G. S. (483)  
Read, Lt. W. R. (463)  
Rees, Lt. Col. W. B. (392)  
Stafford, Sergt. W. G. (438)  
Street, Sergt. E. J. (439)  
Thomas, Sergt. Major  
Vagg, Sergt. H. R. (443)

The above figures are mainly taken from *The Aeroplane*, 1st May, 1913.

\* = under instruction; not yet graded.

[A] Twelve of these *B.E.* were held up pending some special steel wire strainers which had been specified.

### BRITISH AVIATORS—PRIVATE. PRIVATE AVIATORS.

(The number against any name is, unless otherwise stated, the R. Ae. C. pilot certificate number).

Abbott, C. R. (101)  
Aitken, A. H. (56)  
Anderson, J. A. (164)  
Archer, Ernest (Ae. C. F. 214)  
Ballard, F. M. (151)  
Barber, H. (30)  
Barnes, G. A. (16)  
Blackburn, H. (79)  
Bowens, R. G. (39)  
Boyle, Hon. Alan (13)  
Bretherton, John (136)  
Breton, J. (136)  
Brown, H. B. (109)  
Chataway, J. D. (167)  
Challenger, G. H. (58)  
Chambers, C. F. M. (168)  
Cockburn, G. B. (5)  
Cockerell, P. (132)  
Cody, S. F. (9)  
Conway-Jenkins, F. (74)  
Crawshay, R. (133)  
Colmore, G. C. (15)  
Dacre, G. B. (162)  
Darroch, G. R. S. (59)  
Dolphin, W. H. (82)  
Dunkinfield-Jones (138)  
Ducroq, M. (23)  
Dyott, G. M. (114)  
Driver, E. F. (110)  
Egerton, M. Hon. (11)  
England, Gordon (68)  
Esterre, C. R. (Ae. C. F. 259)  
Ewen, W. H. (63)  
Fleming, H. R. (69)  
George, A. E. (19)  
Graham-White, Claud (6) (Ae. C. F. 30)  
Gresswell, C. H. (26)  
Grey, W. H. de (107)  
Halse, E. (131)  
Hamel, Gustav (64) (Ae. C. F. 358)  
Harding, Howard (Ae. C. F. 213)  
Harrison, Eric (131)

Hewlett, Mrs. (122)  
Higginbotham, Gerald (96)  
Hilliard, W. M. (102)  
Hubert, Charles (57)  
Hotchkiss, E. (87)  
Houdini, Harry  
Hucks, B. G. (91)  
Hunter, A. (137)  
Johnston, St. Croix, P. G. (41)  
Johnstone, W. Barnley (103)  
Kemp, R. C. (80)  
Keith-Davies, E.  
King  
Knight, Archibald (60)  
Lawrence, W. (113)  
Longstaffe, J. L. (140)  
Loraine, Robert (Ae. C. F. 126)  
Low, A. R. (34)  
Macdonald, L. F. (28)  
Maron, Louis (62)  
Martin, J. V. Mrs. (55)  
Macfie, R. (49)  
McArdle, W. E. (Ae. C. F.)  
M'Clean, F. K. (21)  
Mellersh, O. S. (155)  
Melly, H. G. (Ae. C. F.)  
Moorhouse, W. B. R. (147)  
Morrison, O. C. (46)  
Moore-Brabazon, J. (1)  
Noel, Louis (116)  
Ogilvie, A. (7)  
Pashley, Cecil L. (106)  
Pashley, E. C. (139)  
Paterson, C. E. (38)  
Paul, E. A. (Ae. C. F.)  
Percival, N. S. (111)  
Petre, H. A. (128)  
Philpott, R. W. (81)  
Pixton, H. (50)  
Prentice, W. R. (67)  
Radley, J. (12)  
Rawlinson, A. (3)  
Raynham, F. P. (85)  
Roe, A. V. (18)

Salmel, H. (99)  
Sassoon, E. V. (52)  
Santoni, L.  
Singer, A. M. (8) (Ae. C. F. 24)  
Slack, R. B. (157)  
Smith, S. E. (33)  
Smith, W. W. (Ae. C. F.)  
Spencer, H. (124)  
Somers-Somerset (Ae. C. F. 151)  
Sopwith, T. (31)  
Stanley-Adams, H. (97)  
Stark (Ae. C. F. 110)  
Stocks, Mrs. C. de B. (153)  
Thomas, J. H. (51)  
Travers, J. L. (86)  
Turner, C. C. (70)  
Turner, L. W. F. (66)  
Valentine, J. (47)  
Watt, W. O. (112)  
Weir, J. D. (24)  
Weston, John (Ae. C. F.)  
Wickham, R. F. (20)  
Woodward, G. A. T. (Ae. C. F.)

*To end of 1912.*

Barnwell, R. H. (278)  
Beech, A. C. (Ae. C. F.)  
Bendall, W. (180)  
Bettington, A. V. (326)  
Birch, E. (322)  
Brock, W. L. (285)  
Cheeseman, W. E. (293)  
Featherstone, W. (384)  
Fowler, F. H. (221)  
Gates, R. T. (225)  
Garne, T. (173)  
Geere, A. E. (310)  
Gill, R. W. R. (258)  
Hall, H. W. (332)  
Hall, J. L. (291)  
Hardman, W. L. (323)

Harrison, W. J. (275)  
Hawker, H. G. (297)  
Hedley, W. S. (274)  
Hewitt, V. (302)  
Higginbotham, V. C. (317)  
Holyoake, R. G. (268)  
James, J. H. (315)  
James, H. H. (344)  
Kershaw, R. H. (248)  
Lister, R. A. (250)  
Nesham, H. P. (219)  
Nevill, M. R. (223)  
Manton, M. D. (231)  
Meredith, C. W. (193)  
Merriam, F. W. (179)  
Parr, S. (184)  
Payze, Arthur (337)  
Potet, A. (224)  
Prensiel, G. (198)  
Simms, R. H. (261)  
Stodart, Dr. D. E. (321)  
Summerfield, S. (292)  
Sutton, E. F. (295)  
Sweetman-Powell, H. (251)  
Taylor, V. P. (376)  
Tremlett, L. A. (208)  
Wood, V. G. (171)  
Wynne, A. M. (314)  
Wright, H. S. (331)  
Yates, V. (306)

**1913** (Brevets from 400 onward).

Andreas, F. G. (477)  
Barron, J. C. (480)  
Hodgson, W. P. (433)  
Kehrmann, J. C. (420)  
King, R. A. (482)  
Lane, H. T. G. (418)  
Lawford, E. H. (442)  
Macandrew, H. E. W. (401)  
Macneill, W. (Ae. C. F.)  
McNamara, J. C. (445)

Minchin, F. R. (419)  
Muller, P. M. (432)  
Temple, G. L. (424)  
Thompson, A. B. A. (452)  
Tower, H. C. (466)  
Rainey, T. H. (474)  
Russell, A. L. (406)  
Stewart, H. (473)  
Strain, L. H. (476)

The following British aviators have been killed:

1910.

Rolls, Hon. C. (2)

1911.

Benson, R.  
Cammell, Lieut. (45)  
Grace, Cecil (4)  
Napier (104)  
Oxley, H. (78)  
Ridge, T. (119)  
Smith, V.<sup>[B]</sup>

1912.

Allen, D. L. (183)  
Astley, J. H. D. (48)  
Bettington, Lt. C. A. (256)  
Campbell, Lindsay (220)  
Clark, Miss J.  
Fenwick, R. C. (35)  
Fisher, E. V. B. (77)  
Gilmour, Graham (Ae. C. F.)  
Hardwick, A.  
Hamilton, Capt. P. (194)  
Hotchkiss, Lieut.  
Lorraine, Capt. (154)  
Petre, Edward (259)

Parke, Lieut. W. (73)  
Wilson, St. Serg. (232)  
Wyness-Stuart, Lt. A.

1913.

Arthur, Lt. Desmond (233)  
Berne, Paym'st'r (R.N.)  
England, G. (301)  
Macdonald, L. F.  
Rogers-Harrison, Lieut. L. C. (205)

<sup>[B]</sup> Killed in Russia.

## BRITISH AEROPLANES

### A

#### AIRCRAFT FACTORY.

Royal Aircraft Factory, Farnborough, near Aldershot. For a long time this establishment had been engaged in dirigible construction and repairs. In 1911 it was decided to expand it in connection with the Royal Flying Corps. Its precise functions are somewhat uncertain. Its nominal main purpose is the repair, etc., of Service Aircraft. During 1912, however, it turned out several machines to a design of its own, known as the "B.E." This design was at one time regarded as confidential; but subsequently duplicates were built by private contractors, and the design illustrated below, published by the Advisory Committee for Aeronautics.

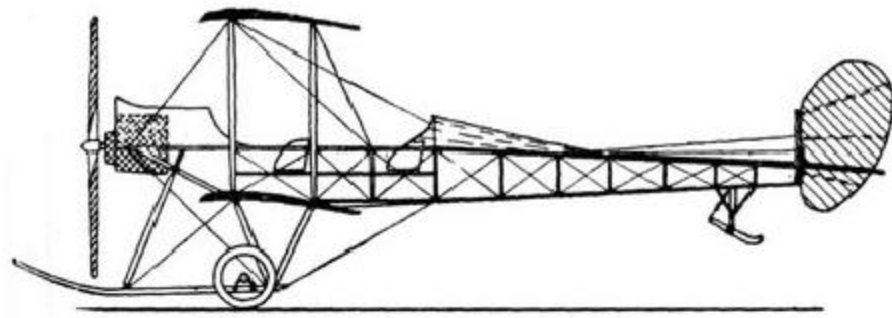

**Length,** 29½ feet (9 m.)

**Span.**—36¾ feet (11.20 m.)

**Area.**—374 sq. feet (34¾ m<sup>2</sup>.)

**Weight.**—

**Motor.**—75 h.p. Renault and others.

**Speed.**—

#### **AERO'S Ltd.**

St. James' Street, Norwich Union Buildings, Piccadilly, London, S.W. Established 1912 for the sale of all parts and accessories; also for the sale of second hand aeroplanes and motors of all makes. Does not construct at present.

#### **AIRCRAFT MANUFACTURING Co., Ltd.**

47, Victoria Street, London, S.W. Works: Hendon, London, N.W. This company established in 1912, holds all the British rights for the *H. & M. Farman* types. It constructs in England all *Farman* types at its own works. (See *Farman*, French).

#### **AVRO. Aeroplanes.**

A. V. Roe & Co., Clifton Street, Miles Platting, Manchester; also Shoreham, Sussex. A. V. Roe designed his first machine, a biplane, in 1906. It was the first British machine to leave the ground. He then experimented with triplanes in Lea Marshes, where he managed to fly with only 9 h.p. in 1908-9. In August, 1910, built *Roe III*, and in September, *Roe IV*, also triplanes (see 1911 edition for full details). In 1911 he abandoned triplanes for the *Avro* biplane. School: Shoreham.

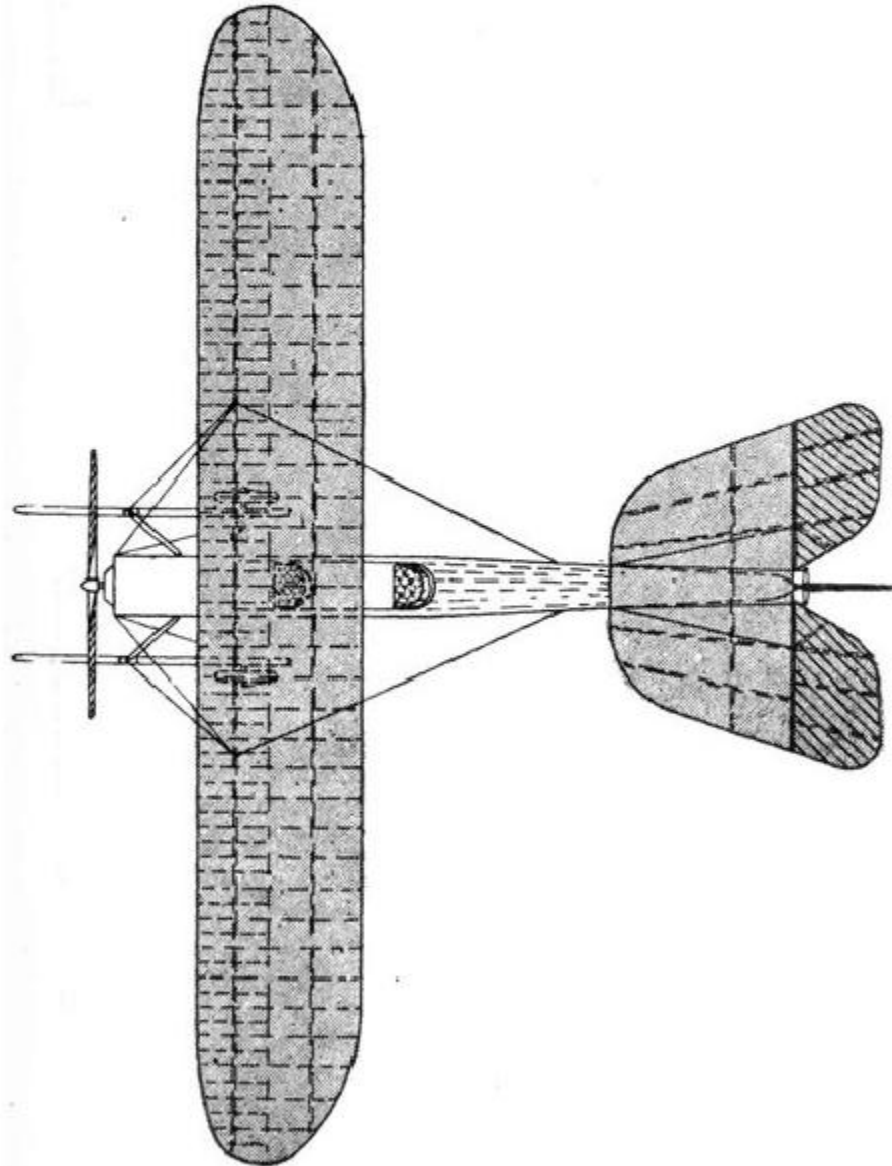

B.E. type. R.A.F. Uniform Aeroplane Scale

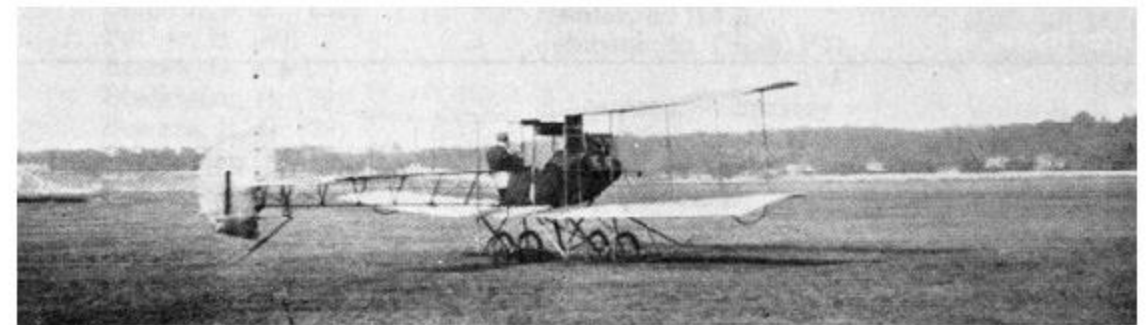

Type D (1911).

Model.		D 1911-12. 2-seater biplane.	E 1912. 2-seater biplane.	F 1912. Totally enclosed mono.	G 1912-13. Totally enclosed biplane.	E 1912-13. Hydro- biplane.
Length	feet (m.)	31 (9.45)	29 (8.84)	23 (7)	29 (8.84)	33 (10)
Span	feet (m.)	31 (9.45)	36 (11)	28 (8.50)	36 (11)	47½ (14.50)
Area	sq. ft. (m <sup>2</sup> .)	279 (26)	335 (32)	158 (14½)	335 (32)	478 (34½)
Weight	empty lbs. (kgs.)	800 (363)	900 (482)	550 (249)	1191 (540)	1740 (789)
	fully loaded, lbs. (kgs.)	...	1300 (589)	800 (363)	1700 (771)	2700 (1224)
Motor	h.p.	35, any make	50 Gnome	40 Viale	60 Green	100 Gnome
Speed	m.p.h. (km.)	48 (78)	61 (97)	65 (105)	61.8 (100)	55 (90)
Number built during 1912		several	6	1	1	1

Remarks.—Of the above, 4 of the 50 Gnome E type were purchased by the British Royal Flying Corps, and one by the Portuguese Government; the other went to Windermere on January, 1913, for hydro experiments. Climbing speed of this type is 440 feet per min. (134 m.) Dual control fitted. D type are no longer being built. Climbing speed of F type, 300 feet per min. (91.5 m.) Gliding angle, 1 in 6. G has a gliding angle 1 in 6.5. On October 24th, 1912, made British record to date, 7'31½" (=450 miles). The hydro. was delivered to the British R.F.C. naval wing early in 1913.

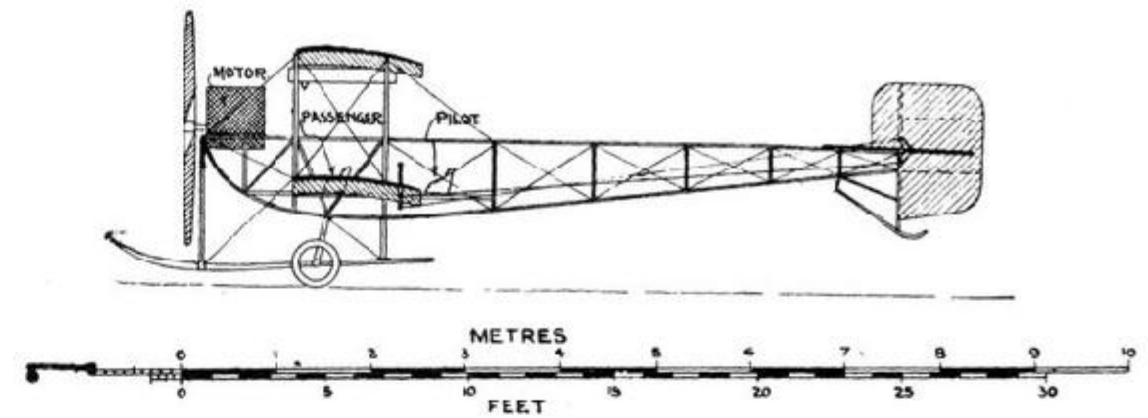

Uniform Aeroplane Scale

Avro. Type D (1911-12).



E type Standard 50 h.p. Avro Biplane.

No suitable photo available.

The machine is on usual lines. The first had a single float, but now two floats are used.

E type 100 h.p. Avro Hydro-biplane.



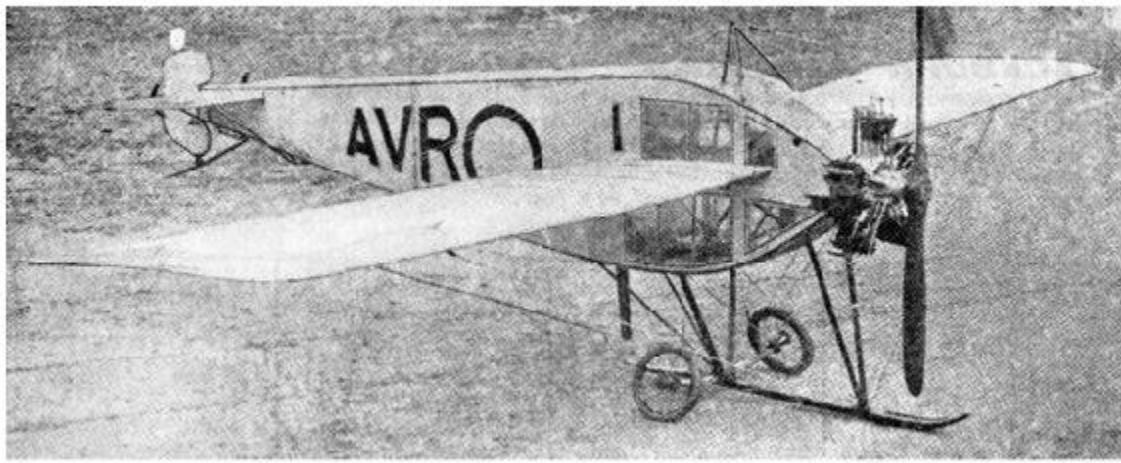

F type Enclosed Avro Mono.

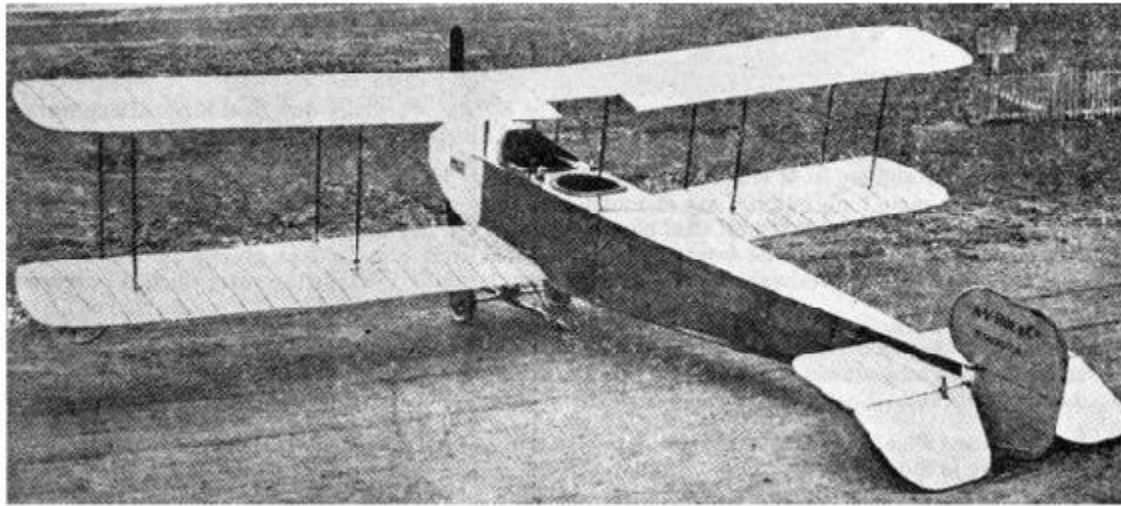

G type Enclosed Avro Biplane.

## B

### BLACKBURN Aeroplanes.

Blackburn Aeroplane Co., Balm Road, Leeds. Blackburn produced his first machine early in 1910 (see 1911 edition for details). In the latter part of that year he designed the machine which ultimately developed into the *Blackburn* military. In 1911 other types were produced, all being fitted with the patent Blackburn triple control. School at Filey Hucks has been the principal *Blackburn* flyer. The type has also been very successfully flown by naval officers. Capacity of works: about 24 a year.

	1912-13. Military. 2-seater.	1912-13. Military. 1-seater.	1913. Hydro-biplane. 2-seater.
Length	32 feet (9.75 m.)	25 feet (7.60 m.)	33 feet (10 km.)
Span	40 feet (12.20 m.)	32 feet (9.75 m.)	44 & 36 ft. (13.40 & 11 km.)
Area	276 sq. ft. (26 m <sup>2</sup> .)	195 sq. ft. (18 m <sup>2</sup> .)	410 sq. ft. (38 m <sup>2</sup> .)
Weight (total)	...	750 lbs. (340 kgs.)	1250 lbs. (507 kgs.)
Motor h.p.	...	50 Gnome.	80 Gnome or 100 Anzani
Speed	55-65 m. (90-105 km.)	60 m. (97 km.)	65 m. (105 km.)

*Notes.*—Petrol for 5 hours (higher endurances can be fitted). Specially designed for military work—all steel construction. All parts unwelded to admit of rapid displacement. Clear observation provided for.

**Fuselage.**—The fuselage is V shaped and constructed of weldless steel tubing in the form of a lattice girder. The main longitudinals are of round section; cross members, oval section. Connections are not welded but made with strong steel clips so that should any member become damaged a new one can be readily arranged. The front portion is covered with sheet metal giving additional strength and reducing the head resistance. Stream line form tapering towards the rear which is covered with fabric.

**Chassis.**—Two long skids connected up to fuselage by metal struts. Each skid borne by a pair of wheels, axle held down by elastic shock absorbers. On the axle of the wheels are fitted steel springs which take side thrust. Each pair of wheels held by radius rods forming a bogie.

**Control.**—Patent Blackburn triple, independent or simultaneous on hand wheel, but special foot control for rudder is fitted if desired.

In 1912, five machines were built, of which two were of the mil. model. Others, non-military models (see last edition.)



Military monoplane.

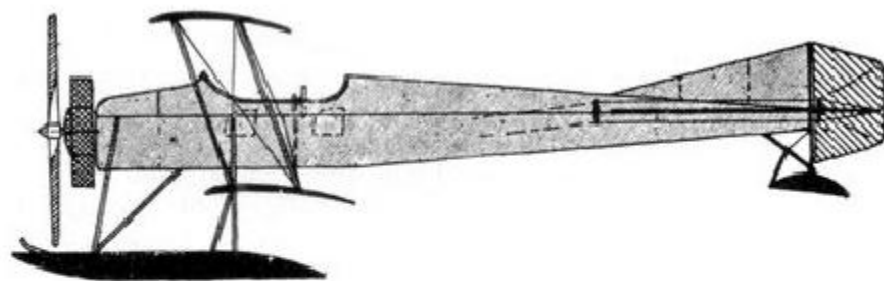
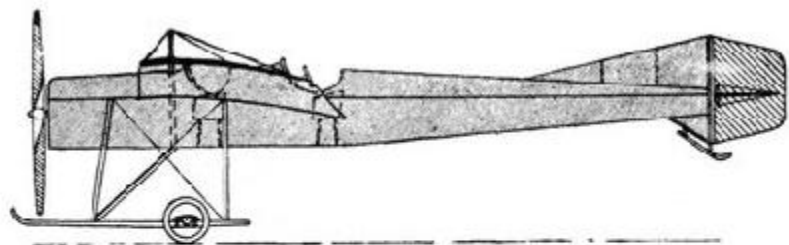

— BLACKBURN. —  
MILITARY TYPE  
TWO - SEATER.

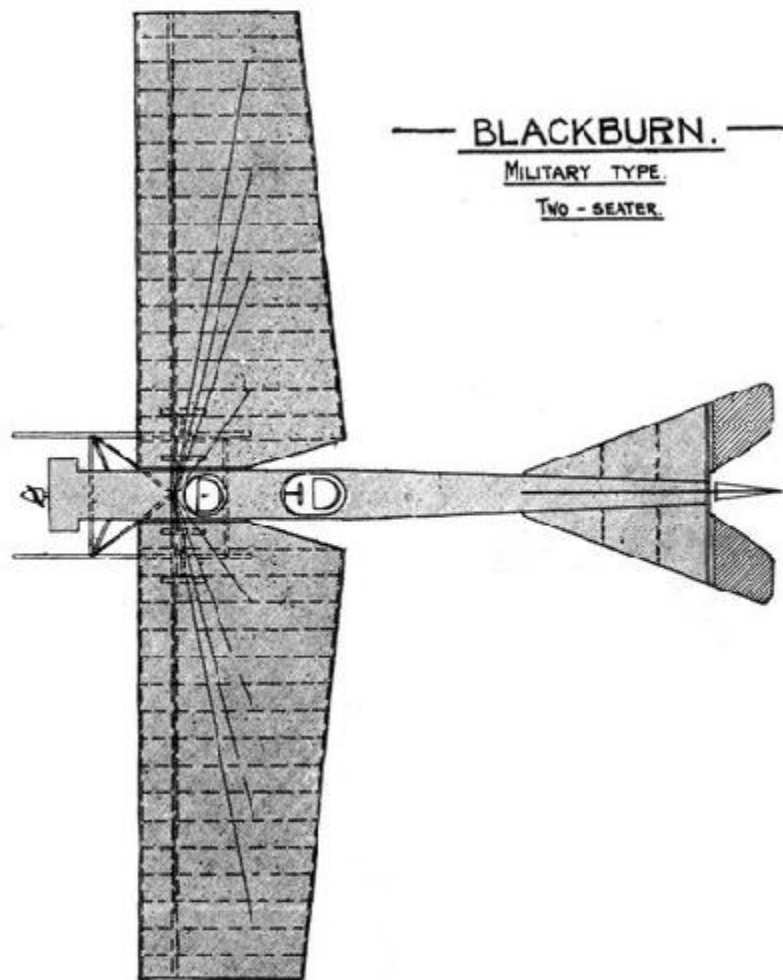

— BLACKBURN. —  
NAVAL TYPE.

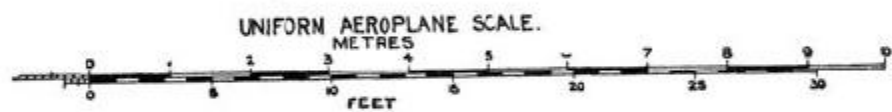
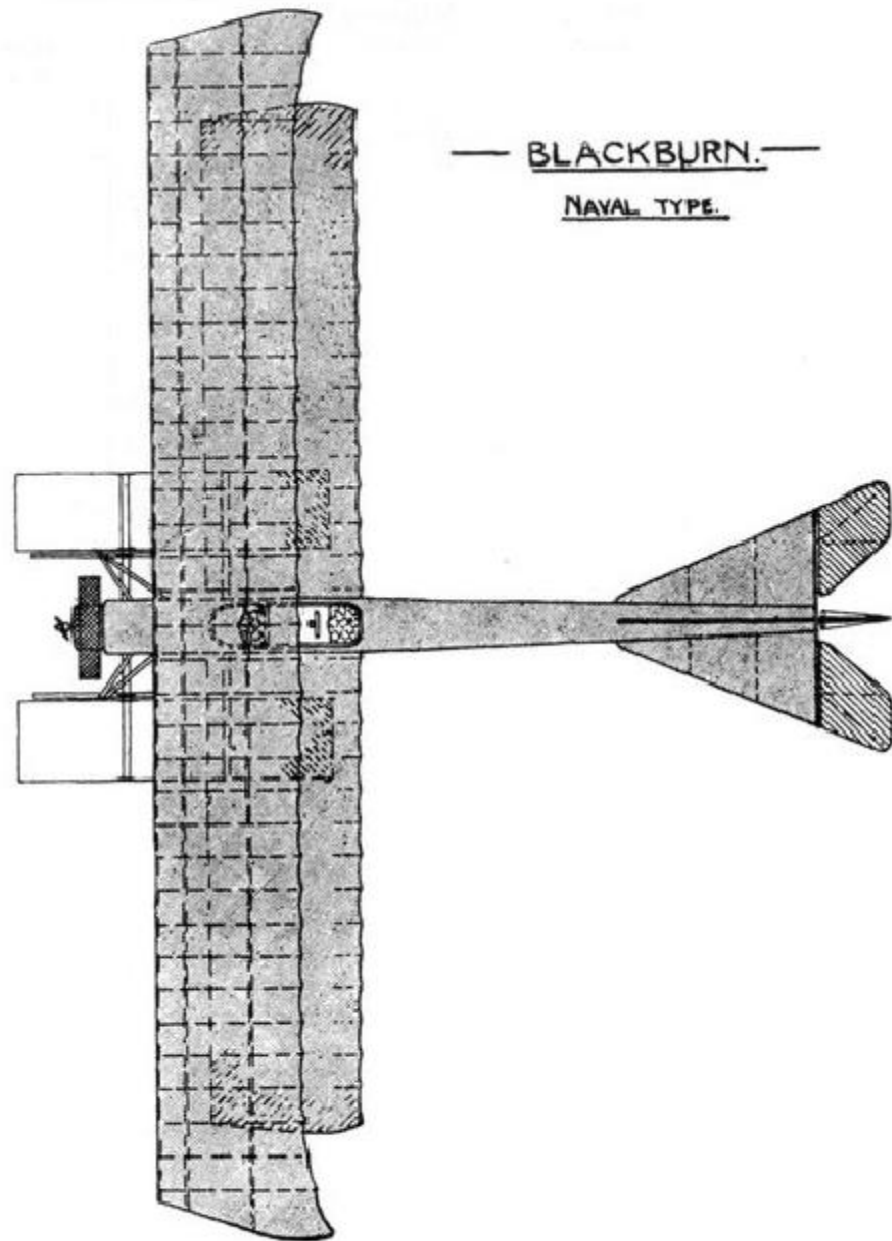

## BRISTOL.

The British & Colonial Aeroplane Co., Ltd., Filton House, Bristol. Founded 1910. Capital (1913), ? Have very extensive works (area. ? sq. feet) on the outskirts of Bristol, employing over 300 men, where they manufacture to their own designs practically every type of flying machine. Flying grounds: Salisbury Plain, Brooklands. 105 Royal Aero Club certificates won on *Bristol* machines during 1912 (of which 86 were officers of His Majesty's Forces).

		<b>Military mono.</b> 2-seater 80hp <b>1912-13.</b>	<b>Military mono.</b> 2-seater. 50h.p. <b>1912-12.</b>	Tractor biplane 1913.	<b>School mono.</b> Side by side.
Length	feet (m.)	28¼ (8.60)	23-2/3 (7.20)	27¼ (8.47)	
Span	feet (m.)	42-1/3 (12.90)	39-1/3 (12)	34-1/3 (10.44)	
Area	sq. feet (m <sup>2</sup> .)	221 (20.6)	226 (22)	370 (34.4)	
Total	machine, lbs. (kgs.)	1719 (771)	1323 (600)	1764 (800)	
weight	useful lbs. (kgs.)	710 (322)	551 (250)	1200 (544)	
Motor	h.p.	80 Gnome	50 Gnome	70 Renault	50 Gnome
Speed	max. m.p.h. (km.)	73 (118)	62 (100)	70 (112)	
	min. m.p.h. (km.)	...	...	...	
Endurance	hrs.	4	3-4	...	
Number built during 1912		...	...	...	

*Notes.*—**Monoplane:** Box section fuselage convex on bottom side to minimise resistance. Mounted on 2 wheels and 2 skids with smaller wheels attached at the forward end. Bristol tractor. **Biplane:** Box section fuselage, convex on top and bottom sides. Mounted as monoplane. Bristol tractor. This machine is the latest production of the Bristol Co., and has proved an exceptionally successful flyer. Designed by M. Coanda.

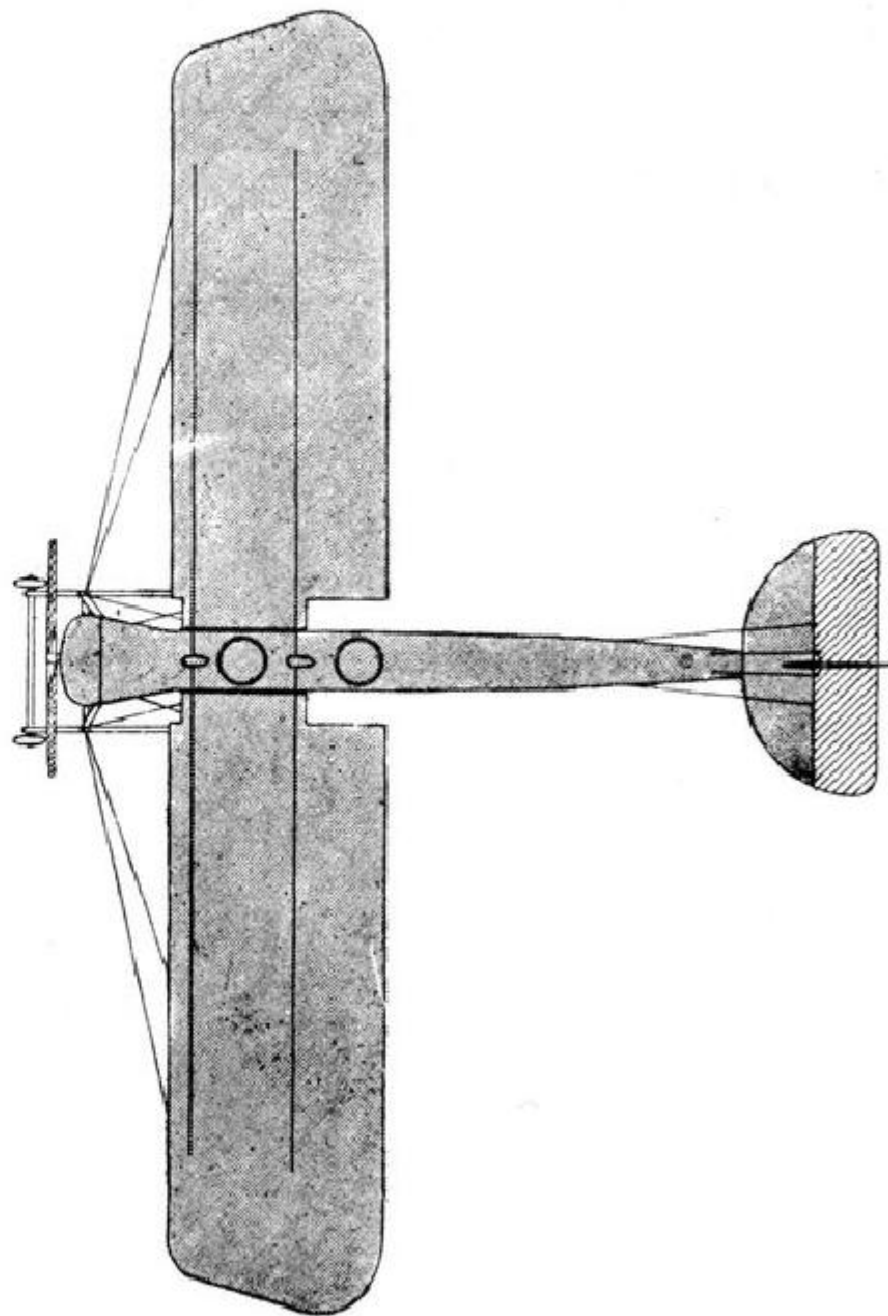
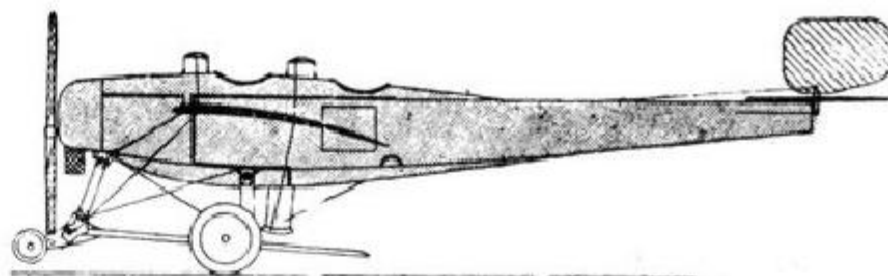

monoplane.

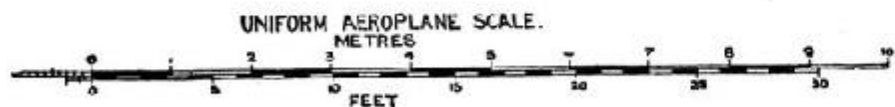
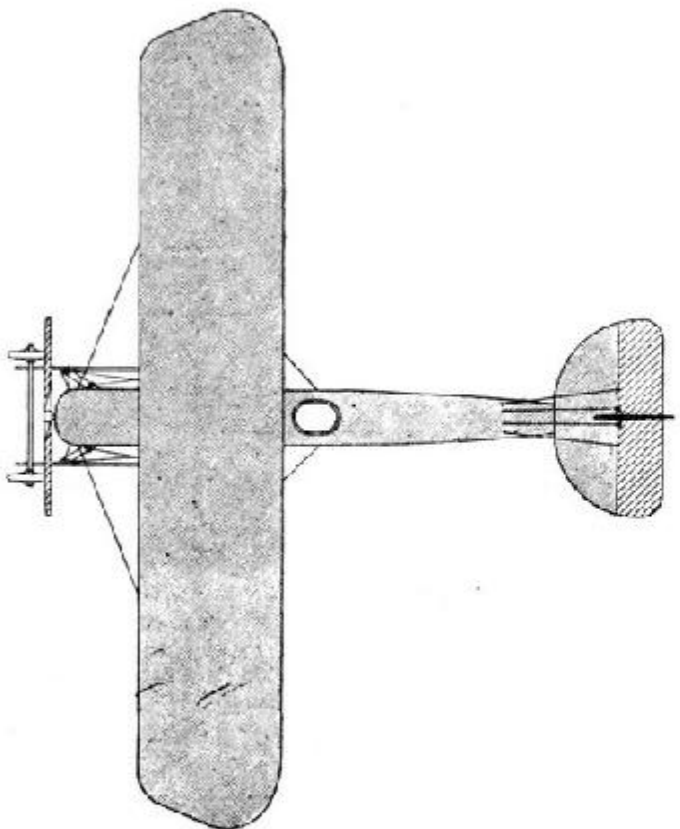
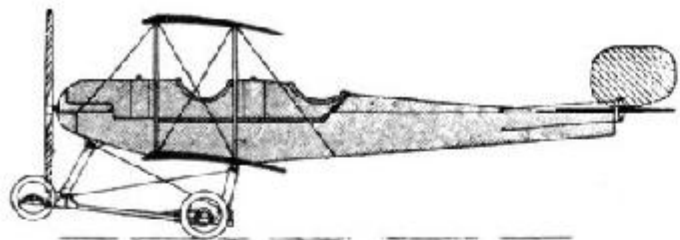

Uniform Aeroplane Scale

70 h.p. biplane.

### BLERIOT Aeronautics.

Belfast Chambers, 156, Regent Street, London, W. School: Hendon. British office of the *Bleriot* firm (see France).

### BRITISH BREGUET CO.,

1, Albemarle Street, Piccadilly, London, W. Works and offices: 5, Hythe Road, Cumberland Park, Willesden, London, N.W. Established 1912. Constructs in England *Breguet* models, some of which are beginning to vary in detail from the originals (see France).

### BRITISH CAUDRON.

(See *Ewen*.)

### BRITISH DEPERDUSSINS.

British Deperdussin Aeroplane Co., Ltd., 39, Victoria Street, Westminster, London, S.W. School: Hendon.

Chairman: Admiral The Hon. Sir E. R. Freemantle, G.C.B., C.M.G.  
Managing Directors: Lieut. J. C. Porte, R.N., D. Laurence Santoni.  
Secretary: N. D. Thompson.

This firm handles the French models of *Deperdussins*, but has in addition a special hydro-aeroplane of its own, of which one was built in 1912. Details of this special machine are:—**Length**, 27 feet 10 inches (8.50 m.) **Span**, 42 feet (12.80 m.) **Area**, 290 sq. feet (27 m<sup>2</sup>.) **Weight**, total, 1,800 lbs. (816 kg.); useful, 1,250 lbs. (566 kg.) **Motor**, 100 h.p. Anzani. **Speed**, 67 m.p.h. (110 k.m.) Other models sold by the firm are of French type exactly (see France).

### BRITISH DONNET-LEVEQUE.

Handled by Aeros, Ltd., 39, St. James' Street, Piccadilly, London, S.W. Company forming March, 1913 (see France). Works and school at Shoreham.

### BRITISH FARMANS.

(See *Aircraft Co.*)

### BRITISH HANRIOTS.

Hewlett & Blondeau, Omnia Works, Vardens Road, Clapham Junction, London, S.W. Construct all types of *Hanriot* machines (see France), also build to private specifications, and deal in accessories generally.

## BRITISH NIEUPORTS.

Company forming 1913. Representative: M. Bonnier, 2, Goulanders Green Crescent, London, N.W.

### C

#### CODY.

Cody flying school, Farnborough. Cody commenced experiments with kites in very early days on behalf of the British Admiralty. Subsequently built the first British Army dirigible, and an experimental Army aeroplane. In 1909, his direct connection with the Army ceased. A *Cody I* was built in 1908. A *Cody II* was completed June 1910. The *special features* of both were: very strong construction, great size (*II* had area of 857 sq. feet), ailerons. Later types, except that warping is substituted for ailerons, do not differ very materially except in minor details. All wood construction.

		1911. 4-seater biplane.	1913. 4-seater biplane.	Model. May, 1912. Monoplane.
Length	feet (m.)	38 (11.60)	38 (11.60)	38 (11.60)
Span	feet (m.)	43 (13)	43 (13)	43½ (13.25)
Area	sq. feet (m <sup>2</sup> .)	484 (44¾)	483 (44¾)	260 (19)
Weight	total lbs. (kgs.)	1900 (862)	1900 (862)	2400 (1088)
	useful lbs. (kgs.)	1000 (453)	1000 (453)	700
Motor		60 Green, later a 100 Green	120 Aust. Daimler	120 Aust. Daimler
Speed	max m.p.h. (km.)	70 (115)	75 (120)	83 (135)
	min m.p.h. (km.)	47 (75)	47 (75)	58 (95)
Number built to end of last year		1	1	1

*Remarks.*—The 1911 is the famous *Cody*, which, as a 60 h.p., won both Michelin 1911 prizes, and completed the *Daily Mail* circuit. As a 100 h.p. it won the 1912 Michelin cross-country. By the end of 1912 it is said to have flown a total of 7000 miles. The 1913 is practically a duplicate with a more powerful engine. *Special features* of the biplanes, maximum camber to lower plane. Both planes equal span. Very strong landing gear. Propeller chain driven: 1¾ to 1 gearing. In February, 1913, four biplanes were ordered for the British Army.

Cody lists a mono. for 1913 a trifle longer than the above; also five variations on the biplane of from 35 to 160 h.p., which can be built if required.

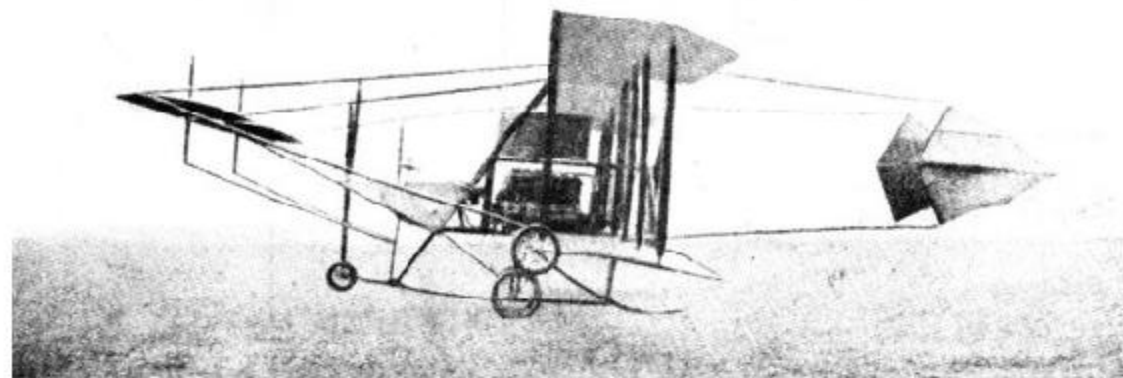

Biplane.

#### COVENTRY ORDNANCE.

The Coventry Ordnance Works, Ltd., Coventry. London office: 28, Broadway, Westminster, S.W. Established 1912. Capacity: 50 machines a year without difficulty.

		1912. Model 10.
Length	feet (m.)	29 (8.80)
Span	feet (m.)	56 (17)
Area	sq. feet (m <sup>2</sup> .)	630 (58)
Weight	total lbs. (kgs.)	1900 (861)
	useful lbs. (kgs.)	800 (362)
Motor	h.p.	100 Gnome
Speed	max. m.p.h. (km.)	60 (97)
	min. m.p.h. (km.)	...
Endurance	hrs.	...
Number Built during 1912		2

*Remarks.*—Experimental machines.

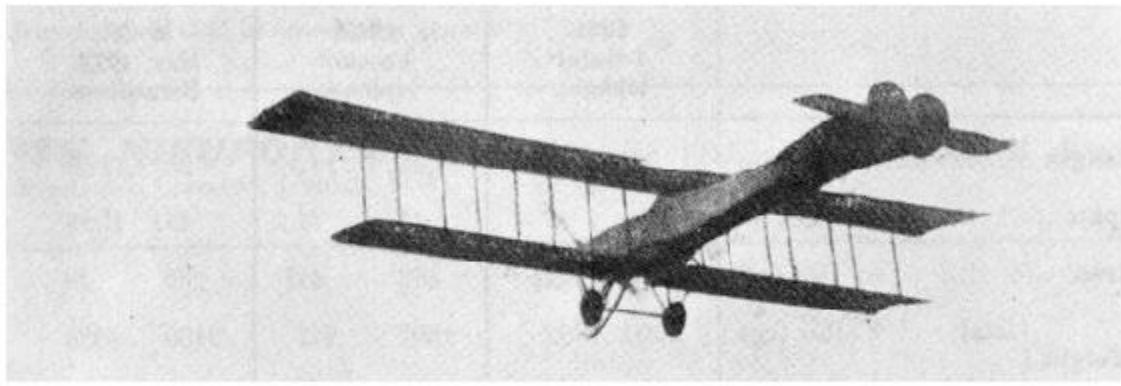

**D**

**DUNNE.**

The Blair Atholl Aeroplane Syndicate, Ltd., 1, Queen Victoria Street, London, E.C. School: Eastchurch. In 1906 Lieut. Dunne was employed by the British Army authorities for secret aeroplane experiments. He had at that time patented a monoplane of < type. In 1907 *Dunne I* was tried on the Duke of Atholl's estate in Scotland, but failed to fly, being smashed on the starting apparatus. *Dunne III*, a glider, 1908, was experimented with successfully by Lieut. Gibbs. In the same year *Dunne IV*, a larger power driven edition made hops of 50 yards or so. Early in 1910 the War Office abandoned the experiments. *Dunne II*, a triplane of 1906 design, was, by consent of the War Office, assigned to Prof. Huntingdon, who made one or two short flights with it at Eastchurch in 1910. At the same time the above syndicate was formed, and *Dunne V*, built by Short Bros., was completed in June, 1910. In 1912-13 the Huntingdon, modified, was flying well.

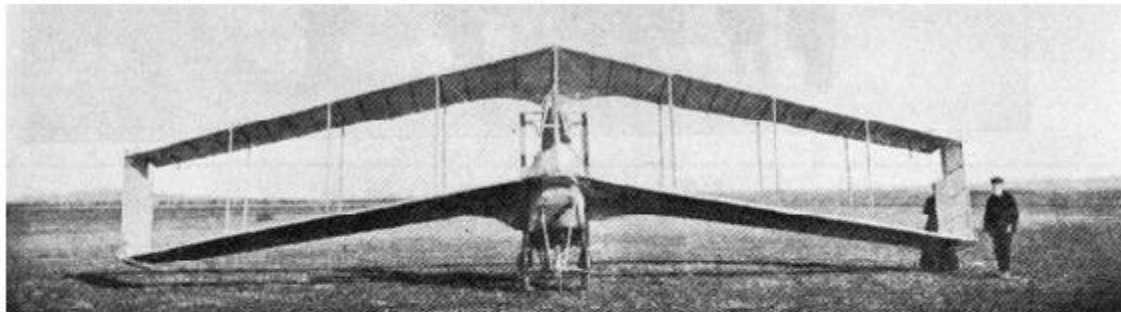

Model and Date.		50 Gnome. 1912-13 single-seat mono. D 7.	1912-13 2-seater mono. D 7 bis.	1912-13 biplane. D 8.	1912-13 biplane. D 9.
Length	feet (m.)	not given	...	...	...
Span	feet (m.)	35 (10.66)	35 (10.66)	46 (14)	45 (13.70)
Area	sq. feet (m <sup>2</sup> .)	200 (18.5)	200 (18.5)	552 (51)	448 (42)
Weight	total lbs. (kgs.)	1050 (476)	1200 (544)	1700 (771)	1693 (768)
	useful lbs. (kgs.)	359 (161)	528 (239)	414 (187)	509 (231)
Motor	h.p.	50 Gnome	70 Gnome	60 Green	80 Gnome
Speed	m.p.h. (km.)	60 (95)	60 (95)	45 (70)	50 (80)
Number built during 1912		1	1	1	5 b'lding ('13)

*Notes.*—Biplane *D 3* is identical with the original pattern *Dunne V*, except that it has only one propeller instead of two. It has been flown completely uncontrolled in a 20 m.p.h. wind, carrying a R. Ae. C. observer as passenger.

E

EWEN.

The W. H. Ewen Aviation Co., London Aerodrome: Hendon. Also works at Lanark, Scotland (opened February, 1913). Hold the British rights for and construct at their works *Caudron* aeroplanes (see France).

F

FERGUSON.

J. B. Ferguson, Ltd., Belfast.

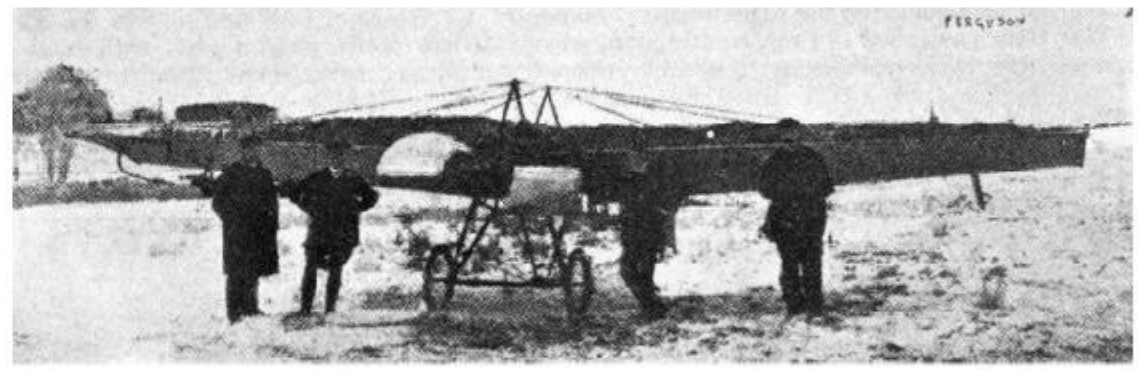

This machine first appeared in 1910. Owing to an accident to Mr. Ferguson it was laid up for a long time. About the end of 1912 it re-appeared. Principal details:—

**Span.**—40 feet (12.20 m.) **Area.**—230 sq. feet (21 m<sup>2</sup>.) **H.P.** 40.

G

GRAHAME-WHITE.

The Grahame-White Aviation Co., Ltd., 166 Piccadilly, London, W. Works and Flying Ground: Hendon. Founded by C. Grahame-White, the well-known aviator, who in 1909 commenced operations with a school at Pau. Later this was removed to England, and a general agency for the sale of aeroplanes, etc., established. This developed, and early in 1911 the firm was handling

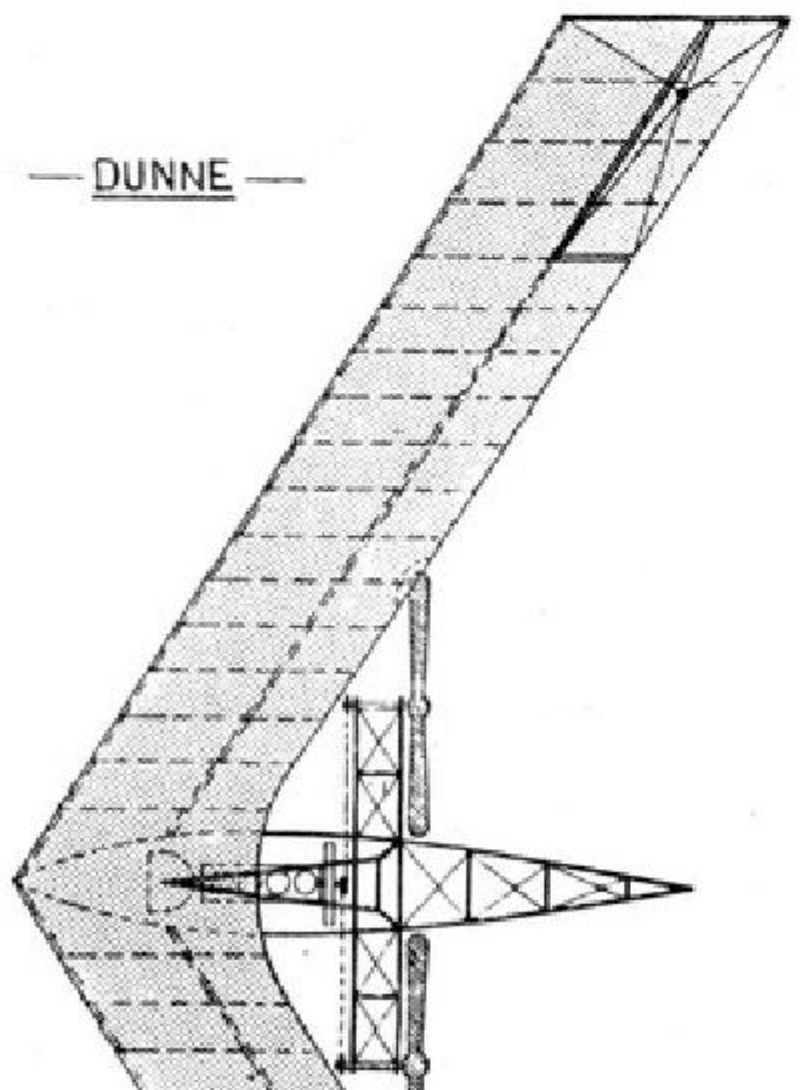
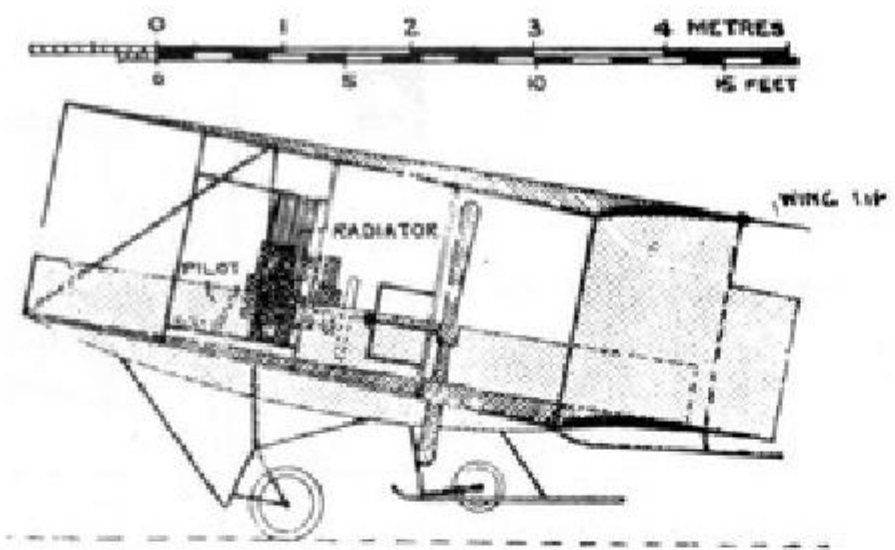

a special British agency for the U.S. *Burgess* type known as "The Baby." The Hendon Aerodrome was acquired, and a factory established, which has grown continually ever since. In April, 1912, a monoplane to special design was completed. By the close of the same year biplanes of advanced design were constructed. Capacity of the works, March, 1913, was equal to 150 machines a year if necessary.

		1913. Military biplane. Type VI. 2-seater.	1913. "Popul ar" biplane  Type VII. 1- seater.	1913. "Popul ar" biplane  Type VII. 2- seater.	1913. Tractor hydro- biplane  Type VIII. 2- seater.	1913. Monoplane. Type IX. single- seat.
Length	feet (m.)	33¼ (10.10)	20-5/6 (6.40)	26-5/6 (8.22)	25 (7.60)	21 (6.40)
Span	feet (m.)	42 (12.80)	29-1/6 (8.85)	38 (11.60)	42½ (13)	32 (9.75)
Area	sq. feet (m².)	435 (40½)	230 (21)	475 (44)	380 (35)	208 (19)
Weight	total lbs. (kgs.)	2200 (997)	...	...	850 (385)	...
	useful lbs. (kgs.)	750 (340)	...	...	450 (204)	...
Motor		120 Aust. Daimler	50 Gnome	50 Gnome	80 Gnome	50 Gnome
Speed	max. m.p.h (k.p.h.)	70 (110)	60 (95)	50 (80)	65 (105)	65 (105)
	min. m.p.h (k.p.h.)	55 (90)	50 (80)	40 (65)	50 (80)	...
Endurance	hrs.	6	4	4	4	4
Number built during 1912		1	...	...	1	...

Also built with a 90  
Aust. Daimler.  
Designed to carry a  
gun on the bow. Very  
good view. Very  
strong landing  
carriage.

Also  
built  
with a  
35

Also  
built  
with a  
60

Also built with a 35  
Anzani. Two main  
floats with 12½ ft.  
track. Floats are 15  
ft. long, 2 ft. wide, 1  
ft. 3 in. deep.

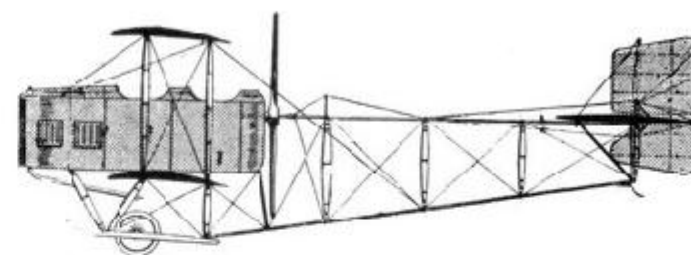

Military Type VI.

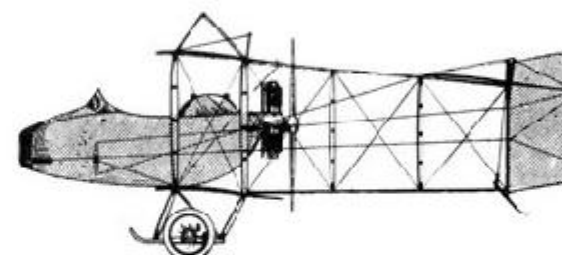

"Popular" biplane. Type VII.

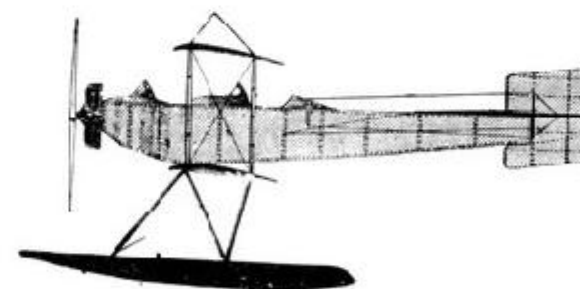

Hydro-biplane. Type VIII.





# H

## HOWARD-FLANDERS.

L. Howard-Flanders, Ltd., 31, Townsend Terrace, Richmond, Surrey. School: Brooklands. Established February, 1912, by Howard-Flanders, whose connection with aviation dates from the pioneer days. Richmond Works opened April, 1912. Capacity of the works at end of 1912 was sufficient to turn out from 25 to 35 machines a year.

		<b>F 4 1912.</b> 2-seater military monoplane.	<b>B 2 1912.</b> 2-seater biplane.	<b>S 2 1913.</b> single-seat monoplane.	<b>F 5 1913.</b> 2-seater monoplane.	<b>B 3 1913.</b> 2-seater monoplane.
Length	feet (m.)	31½ (9.50)	31½ (9.50)	28 (8.50)	31 (9.45)	31 (9.45)
Span	feet (m.)	40 (12)	40 (12)	35 (10.70)	39 (11.90)	40 (12)
Area	sq. feet (m <sup>2</sup> )	240 (22)	390 (36)	190 (17¾)	250 (23)	390 (36)
Weight	total lbs. (kgs.)	1850 (839)	1500 (680)	1180 (535)	1600 (726)	1650 (748)
	useful lbs. (kgs.)	500 (227)	450 (204)	350 (159)	600 (272)	600 (272)
Motor	h.p.	70 Renault	40 A.B.C.	80 Gnome	80 Gnome	80 Gnome
Speed	max m.p.h. (km.)	67 (108)	56 (90)	82 (132)	70 (115)	68 (110)
	min m.p.h. (km.)	41 (66)	38 (61)	45 (73)	42 (68)	40 (65)
Number built during 1912		4	1			

*Remarks.*—*F 4* climbing speed 1000 feet (305 m.) in 3½ minutes, 1500 in 5½ mins., 2000 in 8 mins. *B 2* climbing speed 200 feet (61 m.) per minute. The four *F 4* type were bought by the British Army during 1912.



Monoplane.

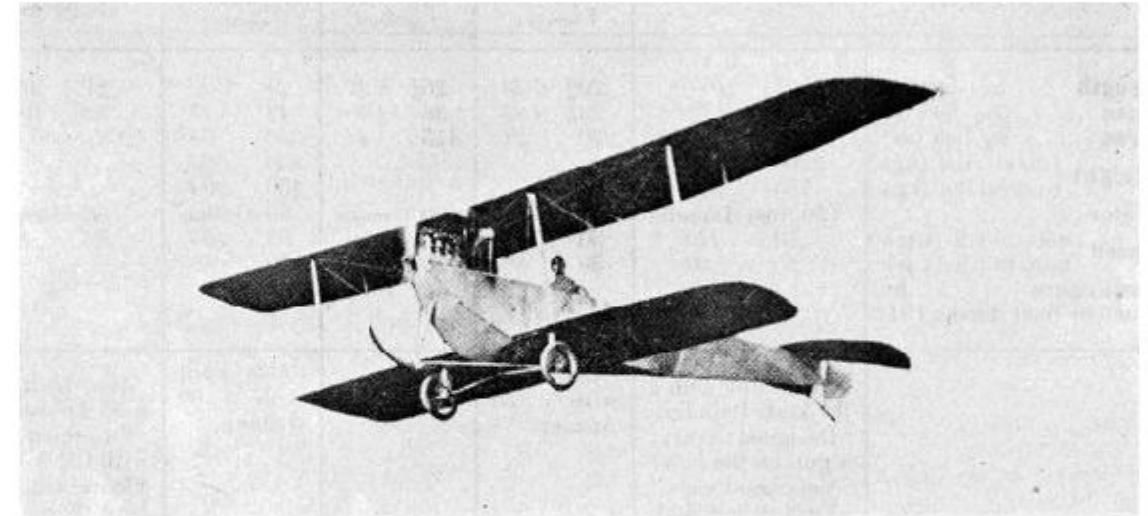

Biplane.

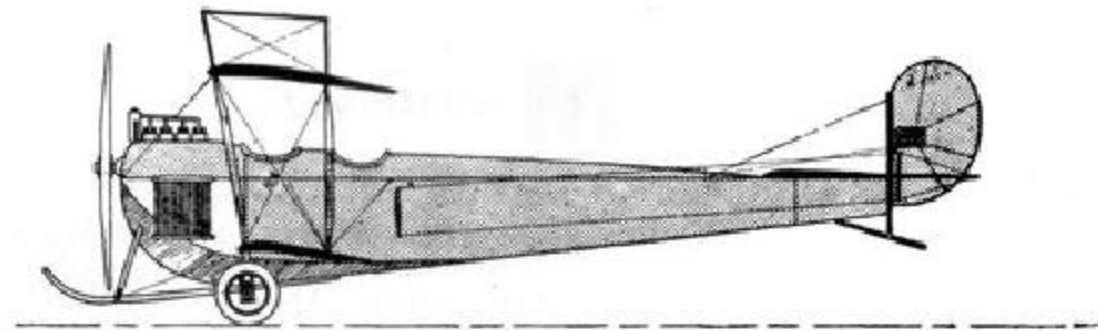
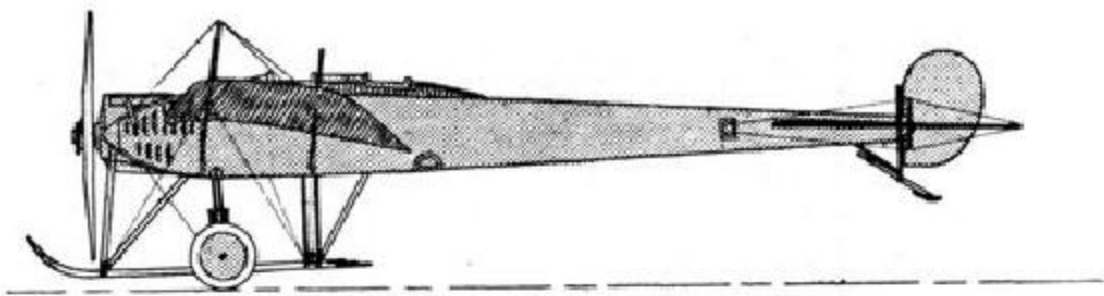

— FLANDERS. —

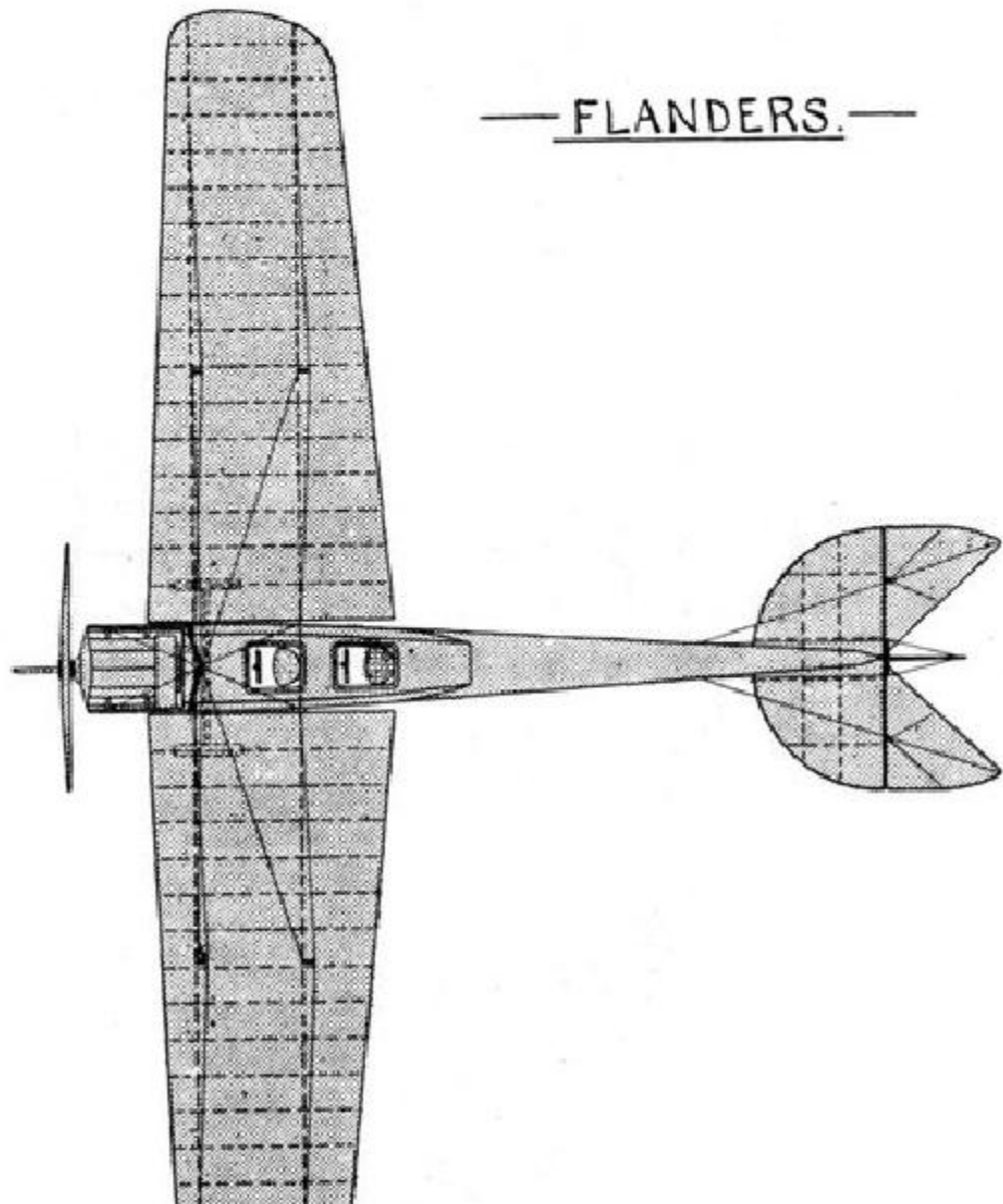

— FLANDERS. —

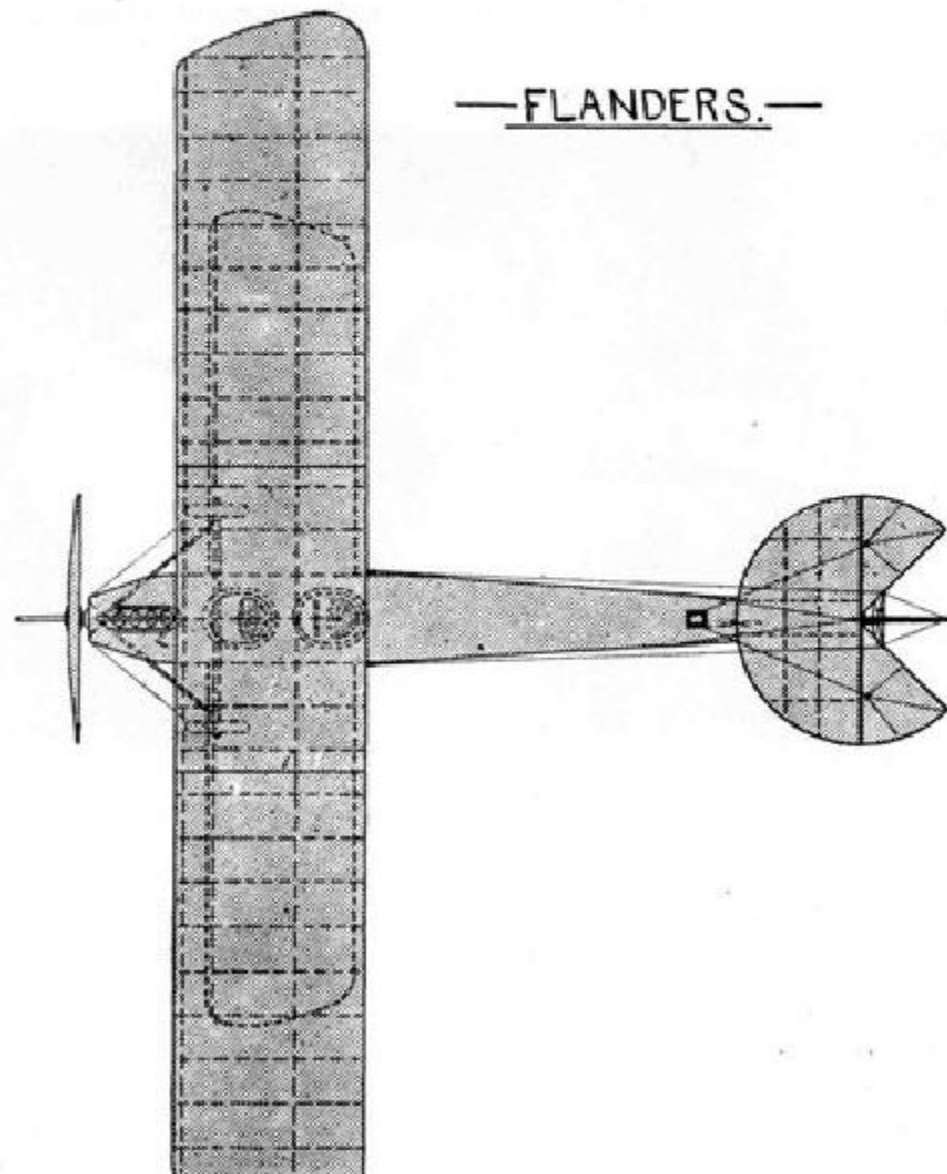

## HANDLEY-PAGE Monoplanes.

Handley Page, 72, Victoria Street, S.W. Works: 110, Cricklewood Lane, N.W. Flying ground: Hendon. Established at the end of 1908. In June, 1909, it was turned into a Limited Liability Co. Since then it has been busily employed in producing its own machines, also others to inventor's specifications. About the end of 1911 the firm bought up and sold all the machines of the Aeronautical Syndicate—*Valkyrie* and *Viking* types. It is doubtful whether any of these V type still exist—in any case it does not matter. Four were presented to the R. Flying Corps. Of these one was smashed up, the others, one army and two navy, were used to teach mechanics to take down and re-assemble engines, etc. Handley-Page also bought up the *Radley-Moorhouse* machines (Bleriot copies), and disposed of them.

The 1912-13 *Handley-Page* type is as follows—a development along regular lines of the original H.P. machine:—

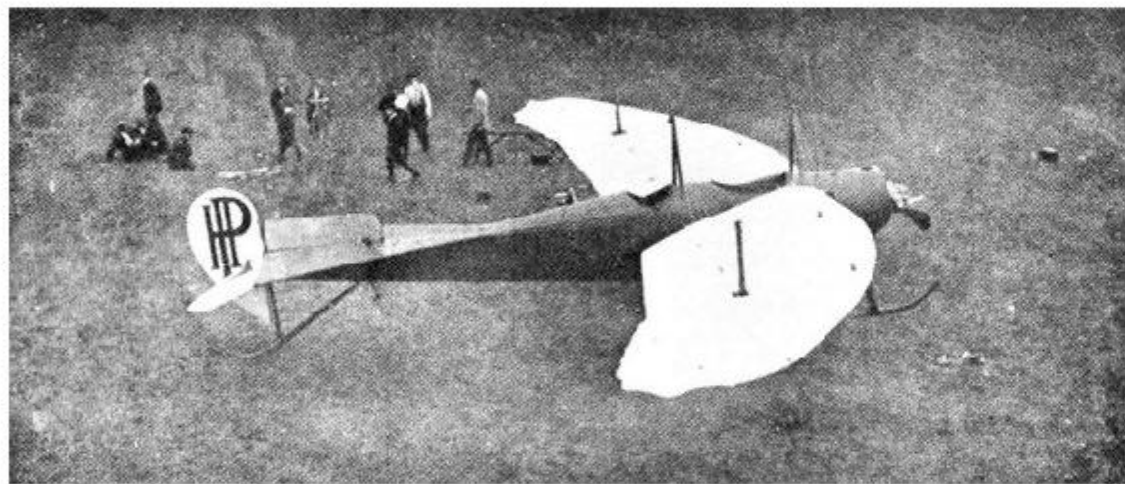

Handley-Page V.

**Length**, 27½ feet (8.40 m.) **span**, 42½ feet (12.95 m.) **area**, 240 sq. feet. (22¼ m<sup>2</sup>.)

**Weight**.—Total, 1300 lbs. (590 kgs.) Empty, 800 lbs. (363 kgs.)

**Motor**.—50 h.p. Gnome. **Speed**. 55 m.p.h. (90 km.)

**Remarks**.—The fixed tail area is 32 sq. feet. Body is entirely enclosed, stream line form. The passenger sits behind the pilot. Mounted on wheels and one long skid forward. Full description and details, *Flight*, 26th October, 1912.

Principal pilots have been the late E. Petre (who made in it the only flight through London), the late Lieut. Parke, R.N., S. Pickles, and L. R. Whitehouse. The machine has been flown with two passengers, in addition to the pilot.

**Military work**.—During 1912 five biplanes of the *B.E.* type were ordered by the British War Office. Several monoplanes were ordered by foreign governments.

L

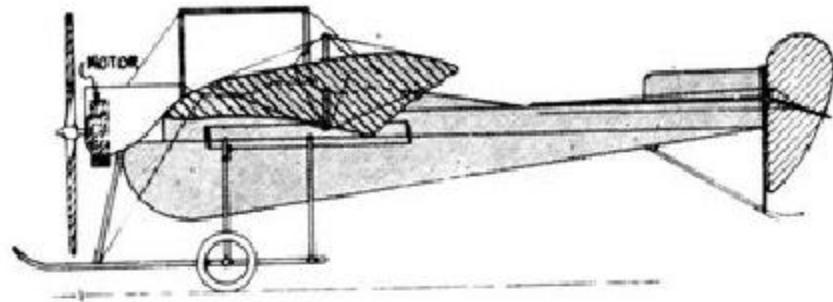
**LAKE FLYING Co.**

Windermere. Established 1911, by E. W. Wakefield, with a view to hydro-aeroplane experiments. The first machine was a *Curtiss* type built by A. V. Roe, which flew in November, 1911. In 1912, a special biplane generally of *Farman* type but with more camber to the planes, was built.

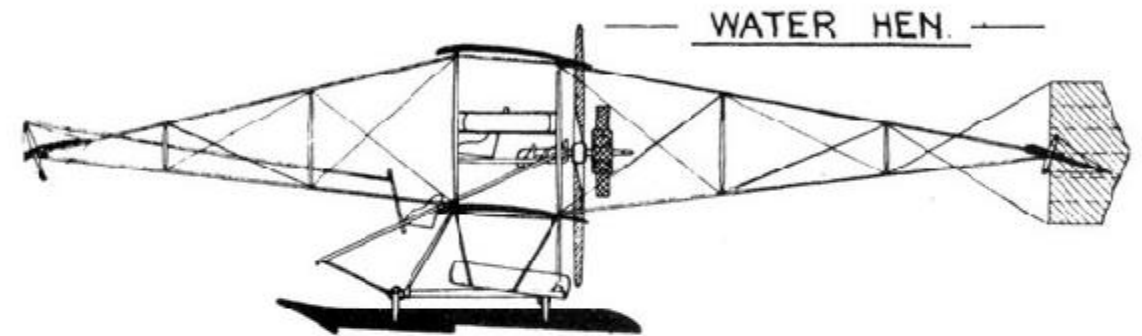
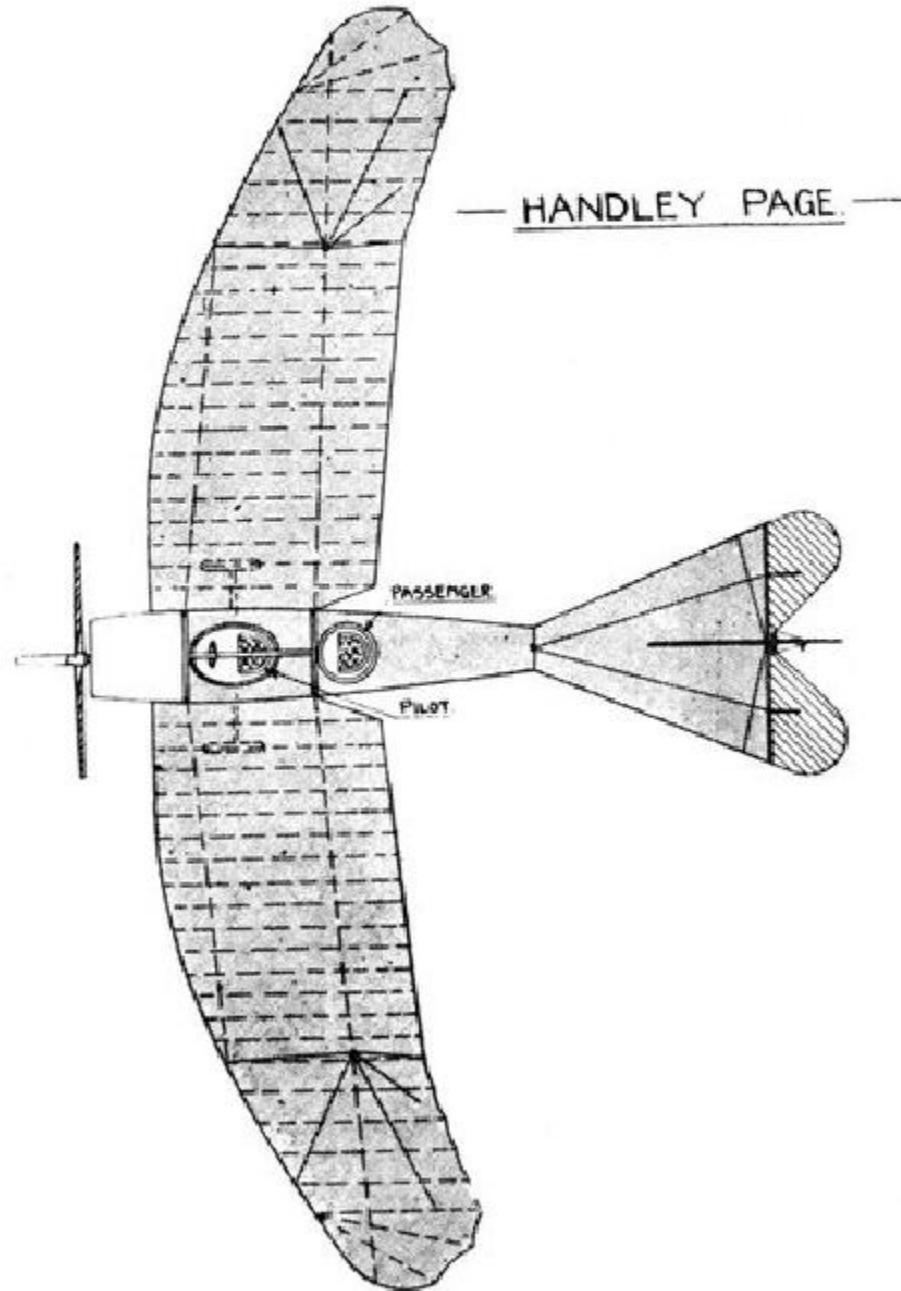

**Length.**—36½ feet (11 m.) **Span.**—42 feet (12.80 m.) **Area.**—270 sq. feet (25 m.<sup>2</sup>) **Motor.**—Gnome.

**Speed.**—45.33 m.p.h. (72.54 k.p.h.)

The single float is 6 feet wide, flexibly connected. Balancers mounted on a spring board. Water rudders for steering at slow speed. Fuller details see *Flight*, December 7th, 1912. Early in 1913, an *Avro* was purchased for further experiments.

M

**MARTINSYDE.**

Messrs. Martin & Handasyde, Brooklands, Weybridge, Surrey. Output capacity: about 20 per annum.

Model and date.	1912.		1913.	
	Mono. 2-seater.		Mono. 2-seater.	
Length	feet. (m.)	35½ (10.75)	35 (10.65)	
Span	feet. (m.)	42½ (12.95)	42¾ (13)	
Area	sq. feet (m <sup>2</sup> .)	290 (27)	285 (26½)	
Weight	total lbs. (kgs.)	...	1212 (550)	
	useful lbs. (kgs.)	...	551 (250)	
Motor	h.p.	65 Antoinette	80 Laviator	
Speed	max m.p.h. (km.)	63 (102)	78 (125)	
	min m.p.h. (km.)	...	...	
Number built during 1912		...	...	

Notes.—Wood construction. Landing: wheels and one skid. Controls: warping wings and rear elevator. Triangular body. The two models are very nearly identical.

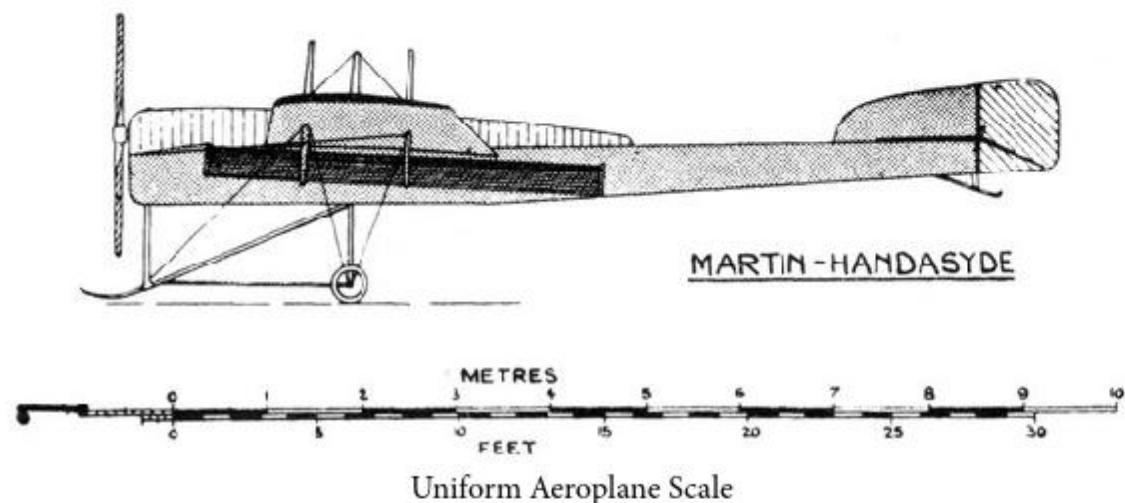

## P

### PIGGOTT.

Piggott Bros. & Co., Ltd., 220, 222 & 224, Bishopsgate, London, E.C. This well-known firm of shed makers built a novel biplane in May, 1910 (details *Flight*, May 21st, 1910), and in 1911 a monoplane with enclosed body (*Flight*, April 1st, 1911). In 1912, both were disposed of, and the firm is not proceeding with its experiments. It has, however, a staff of skilled mechanics and a great deal of floor space for the construction of aeroplanes to specifications.

### PLANES.

Planes, Ltd., 6, Lord Street, Liverpool. Works: Duke Street & Cleveland Street, Birkenhead. Not building at present. In October, 1910, the firm produced a biplane, designed by W. P. Thompson, fitted with a special pendulum stabilising device. This was followed a year or so later by a monoplane.

## R

### RADLEY-ENGLAND.

This is not an aeroplane firm, but a special hydro built by two well-known aviators for the *Daily Mail* competition. **Length**, 22 feet. **Span**, 50 feet. 2 floats, 15 feet long by 1 foot 5 inches wide. Pilot in starboard float. **Weight**, with petrol for 12 hours, 1,380 lbs. **Motor**, 150 h.p., made up of 3—50 h.p. Gnomes, but two Greens to be fitted for competition. One 4-bladed propeller in rear. **Speed**, 60 m.p.h., with 100 h.p.

## S

### SANDERS.

This firm appears to have ceased to exist.

### SHORT BROS.

Works and flying grounds: Eastchurch, Isle of Sheppey, Kent. London office: Queen's Circus, Battersea Park. Took up construction at a very early date. *Wright* agents in 1909. Have built numerous biplanes and monoplanes to specifications. Produced their own first machine (see 1911 edition) in 1910.

		S 41. 1913. Hydro Biplane.			S 45. 1913. Military Tractor Biplane.			S 38. 1913. Military Nacelle Biplane.		S 34. Standard Sch	1911-1	1911-1	
		80 h.p. 2-seater.	100 h.p. 2-seater.	160 h.p. 4-seater.	70 h.p. 2-seater.	80 h.p. 2-seater.	160 h.p. 4-seater.	50 h.p. 2-seater.	80 h.p. 3-seater.	50 h.p. 2-seater.			
Length	feet (m.)	35 (10.67)	39 (11.90)	45 (13.70)	35-1/2 (10.80)	35-1/2 (10.80)	40 (13.70)	35-1/2 (10.80)	35-1/2 (10.80)	42 (12.85)			
Span	feet (m.)	40 (13.70)	50 (15.25)	50 (15.25)	42 (12.90)	45 (13.70)	50 (15.25)	52 (15.85)	52 (15.85)	46-1/2 (14.20)	40-1/2 (12.26)	29-1/2 (9.00)	
Area	sq. feet (m <sup>2</sup> .)	390 (36)	...	...	...	...	...	...	...	...	...	186	
Weight	Machine lbs. (kg.)	1200 (545)	1700 (764)	2000 (909)	1080 (490)	1100 (500)	1890 (860)	950 (432)	1050 (480)	1100 (500)			
	Useful lbs. (kg.)	771 (350)	...	...	...	...	...	...	...	...			
Motor	h.p.	80 Gnome	100 Gnome	160 Gnome	70 Gnome	80 Gnome	160 Gnome	50 Gnome	80 Gnome	50 Gnome			
Speed	max (m.p.h.)	65 (105)	60 (97)	74 (120)	60 (97)	70 (113)	74 (120)	42 (68)	58 (94)	39 (63)			
	min (m.p.h.)	50 (80)	50 (80)	56 (90)	50 (80)	50 (80)	56 (90)	35 (57)	39 (63)	34 (55)	34 (55)	34 (55)	
Endurance	hrs.	4	5	6	5	5	6	4	5	4	5	5	
Number built during 1912		...	...	...	...	...	...	...	...	...	...	...	
<i>Remarks.</i> --Floats are two long pontoons. Subsidiary floats at tips of lower plane. Small tail float with water rudder. W.-t. compartments to floats. Tandem seated, pilot in front. The observer's seat can accommodate two if necessary.					Tandem seats, pilot in front. Fittings for maps, etc.			Specially designed for reconnaissance. Tandem seats, pilot in front. An extra passenger can be accommodated.		Solely designed for school work. Seats side by side.		No longer built, but still in existence.	

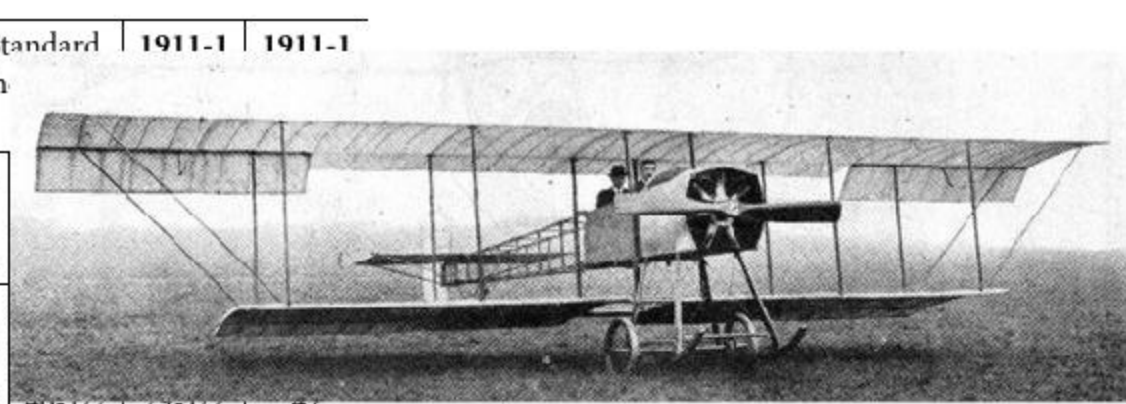

Old 1911-12 tractor biplane.

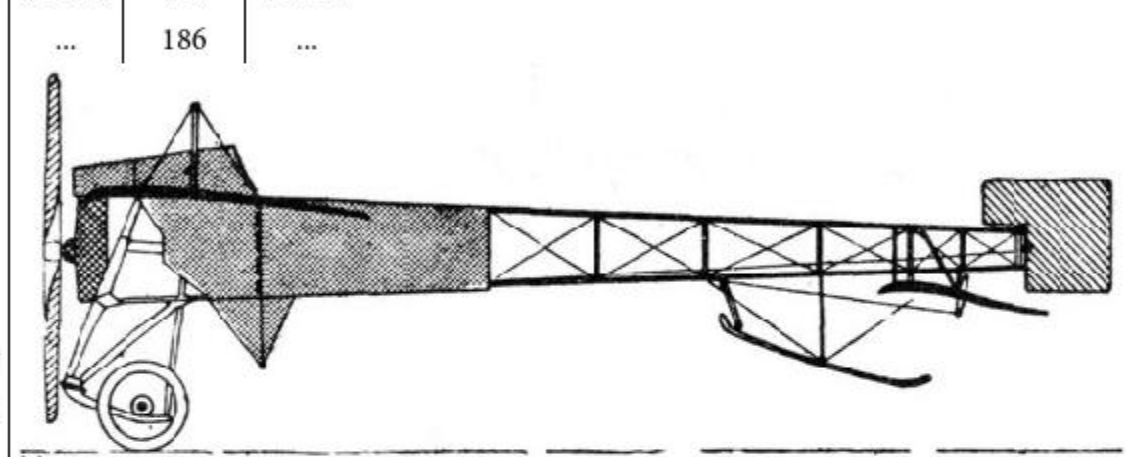

Old 1911-12 mono.

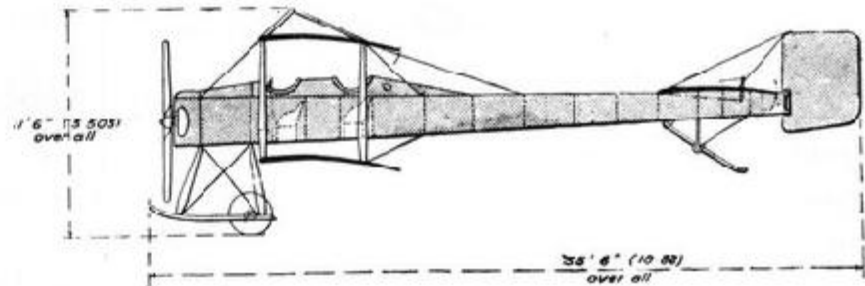
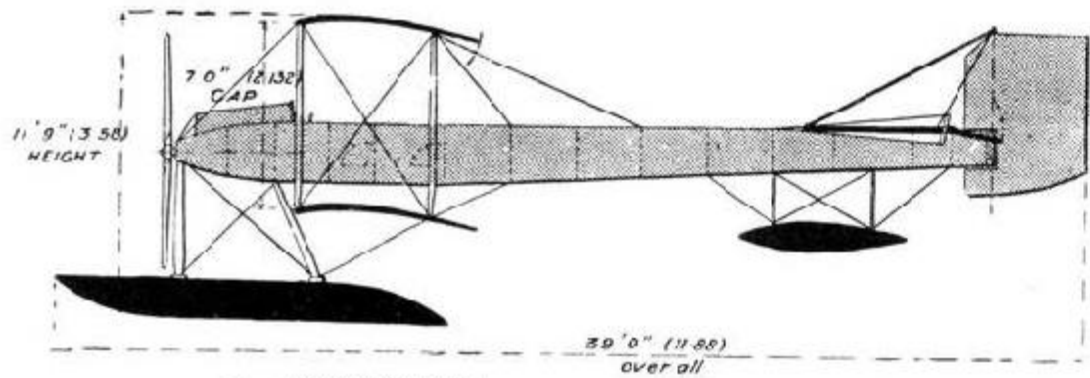

Short. S. 45 type.

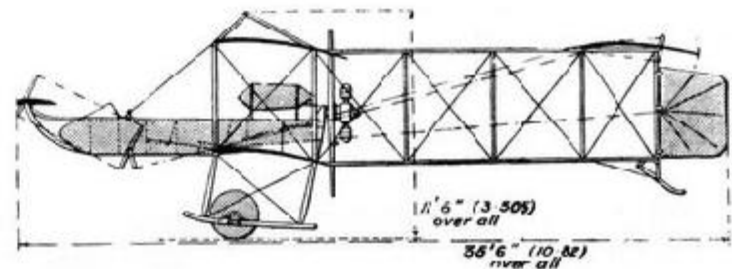

Short. S. 38 military.



Uniform Aeroplane Scale

**SOPWITH.**

Sopwith Aviation Co. Works: Canbury Park Road, Kingston-on-Thames. School: at Brooklands. Established by T. O. M. Sopwith, the well known aviator at Brooklands, Autumn of 1911, where during 1912, a 70 h.p. tractor biplane and a 40 h.p. biplane was turned out.

Floor area of the Kingston works in March, 1913, was 30,000 sq. feet with electric power plant. Works manager: F. Sigrist. General manager: R. O. Cary. Output capacity: at full pressure about 50 machines a year.

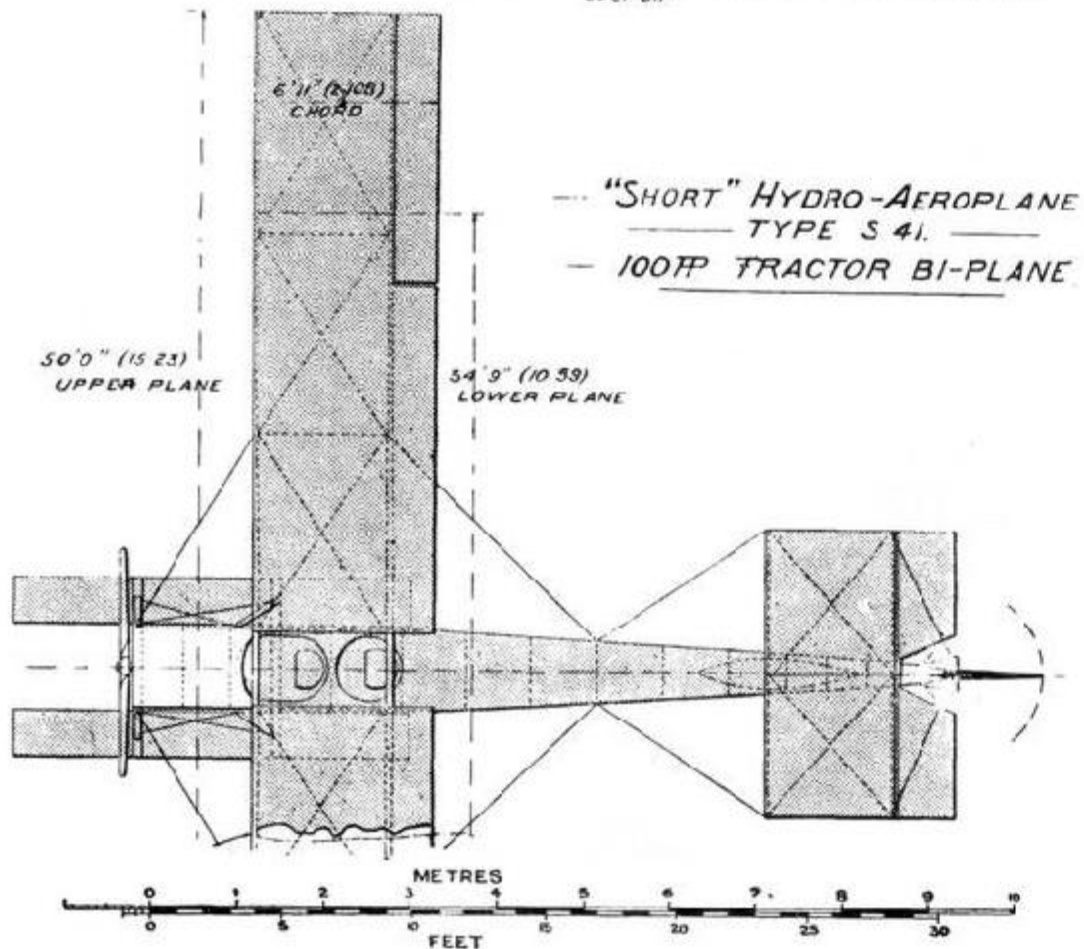

Uniform Aeroplane Scale

Short. Hydro.

Model and Date.		1913. Bat boat hydro biplane.	1913. Tractor biplane 3-seater.	1913. School biplane.	1913. Armoured warplane.
Length	feet (m.)	30-1/3 (9.20)	29 (8.85)	29 (8.85)	29' 7-1/2" (9)
Span	feet (m.)	41 (12.50)	40 (12.20)	40 (12.20)	50 (15.25)
Area	sq. feet (m <sup>2</sup> .)	422 (39)	365 (34)	400 (37)	552 (51)
Weight	total lbs. (kgs.)	1700 (771)	1750 (794)	1200 (544)	2000 (907)
	useful lbs. (kgs.)	500 (227)	750 (340)	400 (181)	800 (362)
Motor	h.p.	90 Austro- Daimler	80 Gnome	50 Gnome	90 Austro- Daimler
Speed	max. m.p.h. (km.)	65 (105)	74 (125)	48 (78)	65 (105)
	min. m.p.h. (km.)	42 (68)	40 (65)	35 (60)	38 (61)
Endurance	hrs.	...	...	...	...

Notes.—Wood construction. Carriage wheels and skids. *Control*: balanced ailerons.



Sopwith. Flying boat.

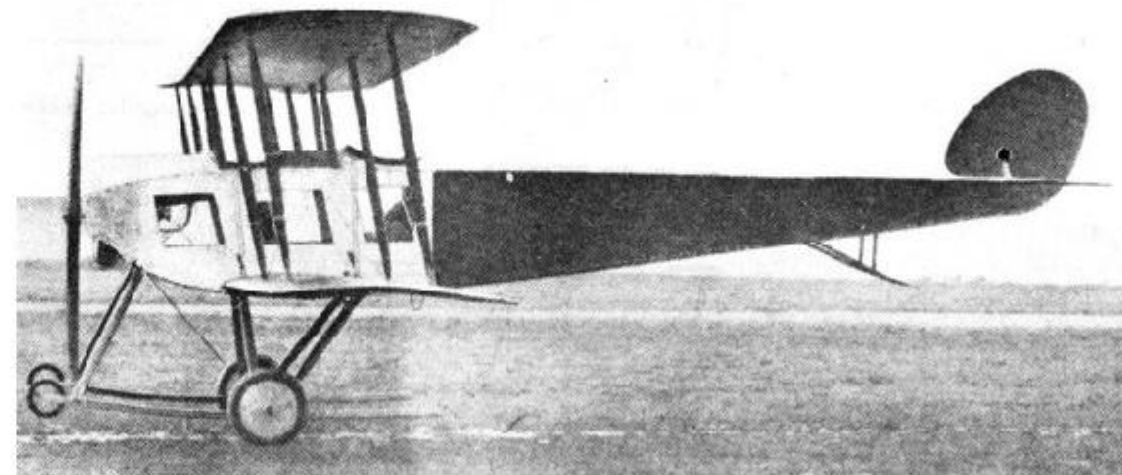

1913. Tractor biplane.

V

## VICKERS.

Vickers, Ltd., Vickers House, Broadway, Westminster. School: Brooklands. Seven pupils qualified during 1912.

Model and date.		Monoplane. 1912-13. 2-seater.	Military biplane. 1913.
Length	feet (m.)	25 (7.60)	...
Span	feet (m.)	34-1/2 (10.50)	40 (12.20)
Area	sq. feet (m <sup>2</sup> .)	220 (20)	385 (35)
Weight	{total, lbs. (kgs.)	730 (331)	...
	{useful, lbs. (kgs.)	...	...
Motor	h.p.	80 Gnome	80 Wolseley
Speed	m.p.h. (km.)	70 (115)	...
Endurance	hrs.	3	...
Number built during 1912		...	...

Notes.—Steel construction. Landing shock absorbing: 2 wheels and 1 skid. Rectangular enclosed body. *Controls*: warping and rear elevator.



**Monoplane** climbs 300 feet a minute fully loaded.

**Biplane** is armed with a Vickers R.C. automatic gun in the bow.

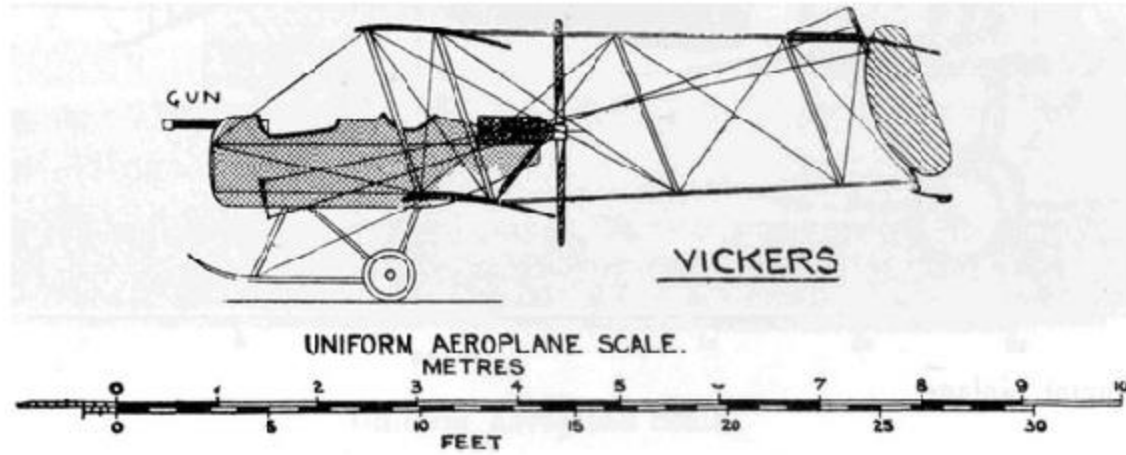

VICKERS. Uniform Aeroplane Scale

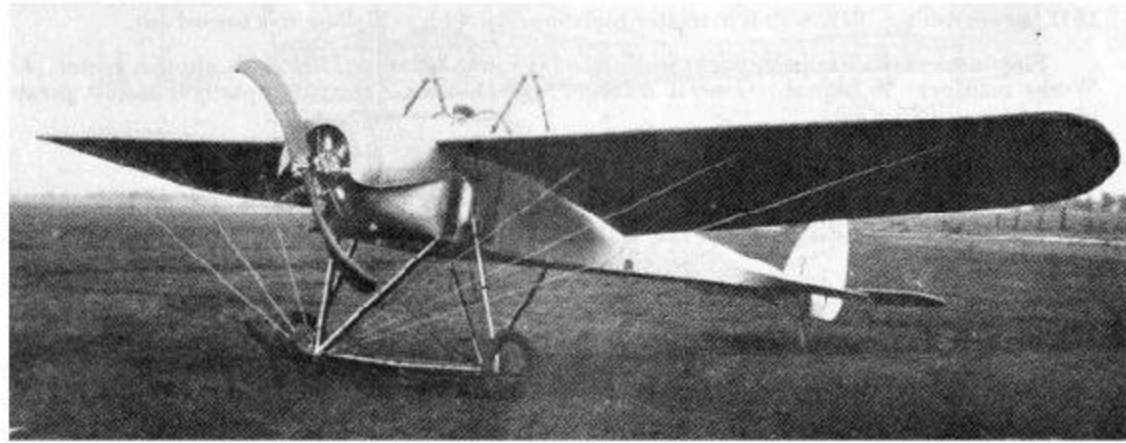

Vickers. Monoplane.

Vickers. Armed biplane.

## W

### WHITE.

J. Samuel White & Co., Ltd., shipbuilders and engineers, East Cowes, Isle of Wight. London office: 28, Victoria Street, S.W. This well-known firm of torpedo craft builders, etc., formally opened an aviation department on 1st January, 1913, with Howard T. Wright as general manager and designer.

		1913. Navy 'plane.
Length	feet (m.)	30 (9.15)
Span	feet (m.)	44 (13.40)
Area	sq. feet (m <sup>2</sup> .)	500 (46-1/2)
Weight	total lbs. (kgs.)	2000 (907)
	useful lbs. (kgs.)	650 (295)
Motor	h.p.	160 Gnome
Speed	max. m.p.h. (km.)	70 (115)
	min. m.p.h. (km.)	35 (57)
Number built		...

*Remarks.*—Hydro-biplane, with Howard T. Wright patent aeroplanes to give wide range of speed. Two patent hydro floats, 21 feet (m.) long, three steps on each.

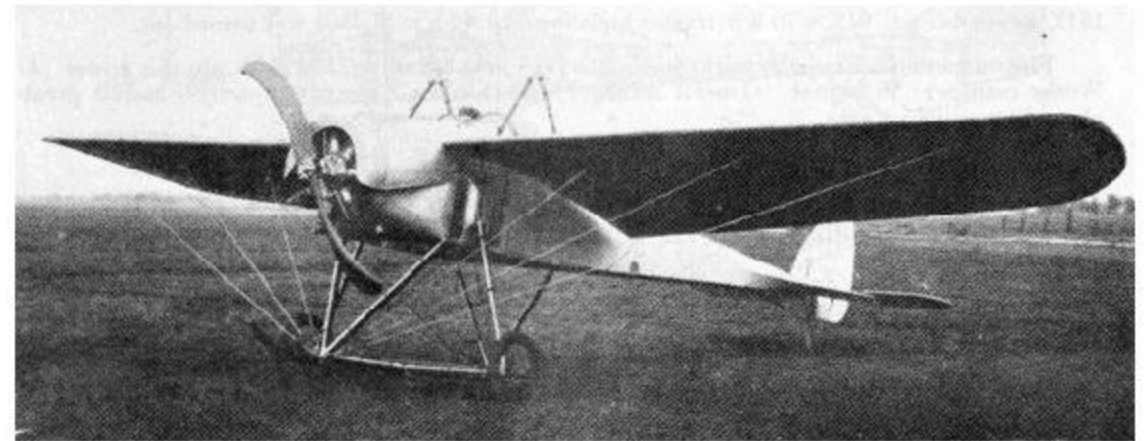

Uniform Aeroplane Scale

## BRITISH DIRIGIBLES.

*Notes.*—All the above are non-rigid. The military ones were all built at the Royal Aircraft Factory.

		Navy.			Army.	
Name and date.		II Willows 3. 1911.	III Astra Torres 2. 1913.	IV Parseval 18. 1913.	II BETA. 1909 (1910.)	III, & IV & V GAMMA, DELTA, EPSILON. 1910, 1912, 1913.
Volume	c. feet (m <sup>3</sup> .)	31,800 (900)	222,500 (6,500)	311,000 (8,800)	21,000 (594)	70,600 (2,000)
Length	feet (m.)	120 (36.50)	...	276 (84)	104 (31.70)	152 (46)
Diameter	feet (m.)	40 (12.20)	...	49¼ (15)	25 (7.60)	30 (9.10)
Gasbags	fabric	Spencer	Continental	Metzler	Gold beater skin	Continental
	compartments	nil	3	nil	nil	nil
	ballonets	1	1	2	1	2
Lift	total tons	about ½	about 7	about 10	about ¾	2 ☒
	useful, tons	...	...	...	...	...
Motors	h.p.	30 (=30)	2—120 Chenu (=240)	2—180 Maybach (=360)	1—30 Green (=30)	2—50 Green (=100)
Propellers	number	2 (swivel)	2	2 (s.r.) steel	1	2 (swivel)
	blades	2	2	4	2	2
	diameter feet (m.)	...	...	...	...	...
Speed	max. m.p.h. (km.)	...	38 (63)	42 (68)	18 (29)	28 (45)
Endurance	full speed	...	...	...	...	4 hours
Max. complement		2	15-18	10-12	3	5
Station		Farnborough	...	...	Farnborough	Farnborough

### Navy Dirigible Pilots.

Boothby, Lieut. F. L. M. (*F.C.*)  
 Everett, Gunner F.  
 Masterman, Comdr. E. A. D. (in command)  
 Osborne, Lieut. N. F. (squad comdr.)  
 Woodcock, Lieut. H. (*F.C.*)

### Undergoing Naval Aircraft Course:

Crocker, Lieut. W. R.  
 Hicks, Lieut. W. C.  
 Wilson, Lieut. R. A.

### Military Dirigible Pilots.

### Squadron Commanders.

Maitland, Capt. E. M.

### Flight Commanders.

Waterlow, Lieut. C. M.

### Flying Officers.

Brabazon, Capt. Honble. C. M. P.  
 Fletcher, Lieut. J. N. (R.E.)  
 Hetherington, Lieut. T. G.  
 Mackworth, Lieut. J. D.  
 Pigot, Capt. R.

The following hold dirigible pilot certificates, but are not at present employed:—

Broke Smith, Capt. P.  
 Capper, Col. J. E.

Fox, Lieut. A. G.

### Private Dirigibles.

There are one *Willows* (1912) (sister to the naval one) and a couple of *Spencers* about the size of *Beta*.

### Private Dirigible Pilots.

Willows, E. T. (24-32, Villa Rd. Handsworth, Birmingham).

### BRITISH NAVAL DIRIGIBLES.

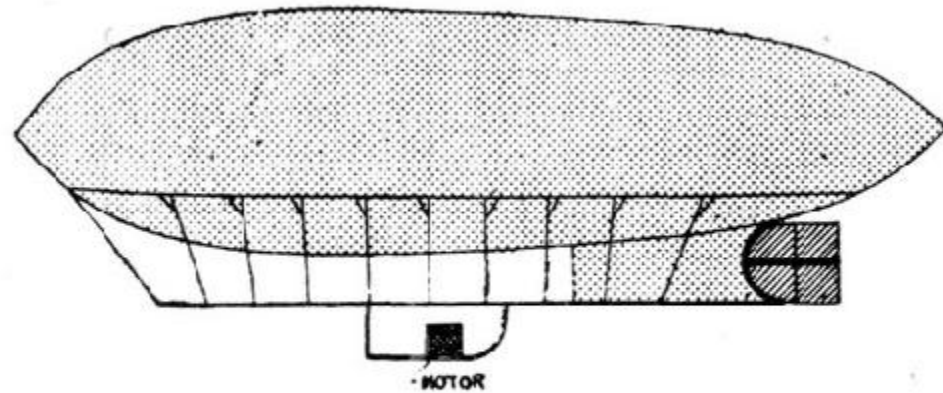

Willows. The naval one is fitted with a boat-shaped car.

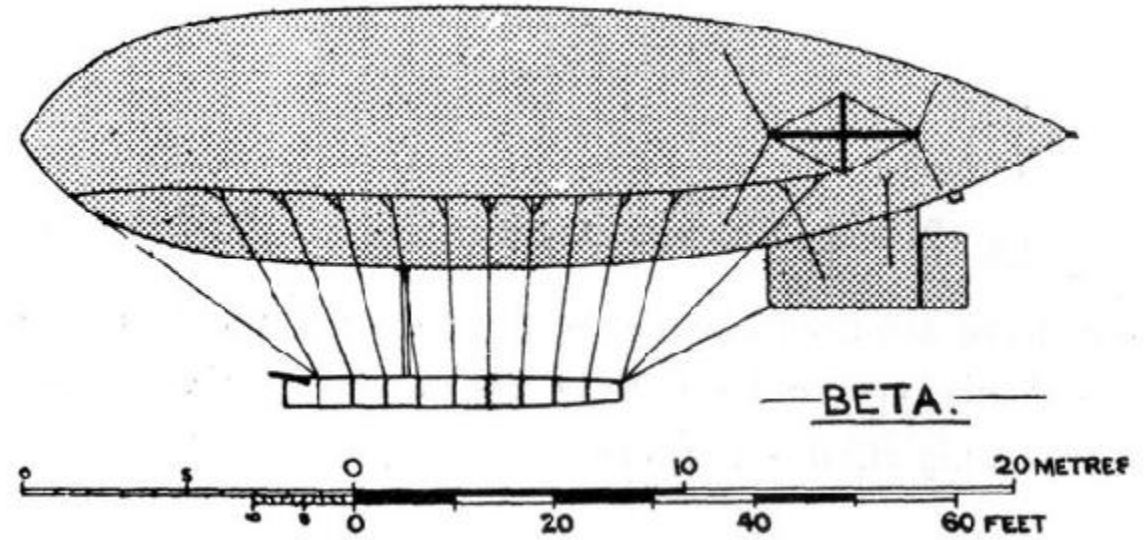

Parseval. (photo of a sister ship.)

### New Construction.

Messrs. Vickers have acquired the Parseval rights for the British Empire, and several airships of this type are likely to be put in hand by them shortly.

Also reported that a big rigid is projected.

# BRITISH MILITARY DIRIGIBLES.

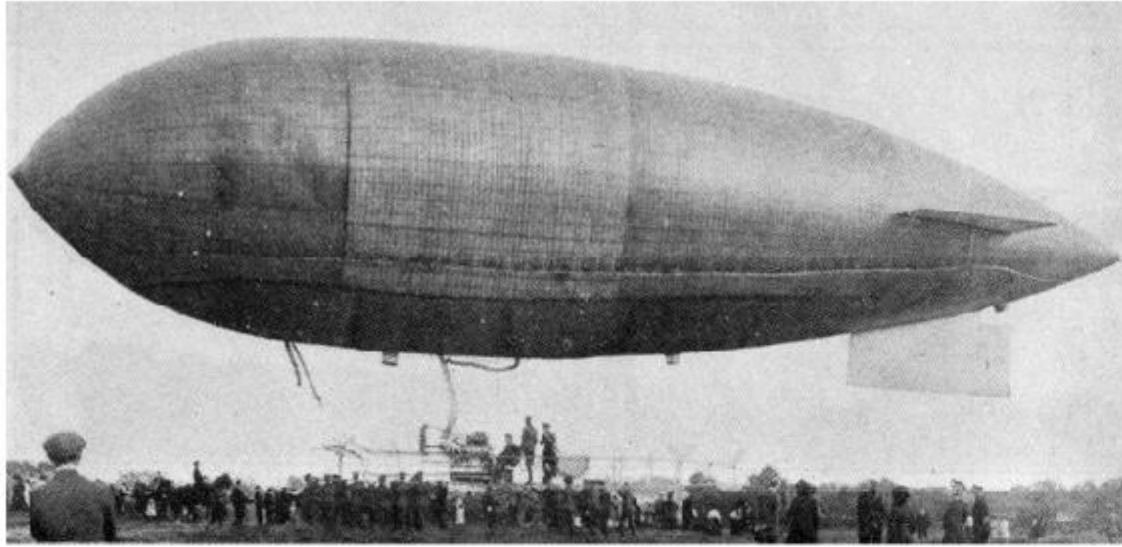

Beta.

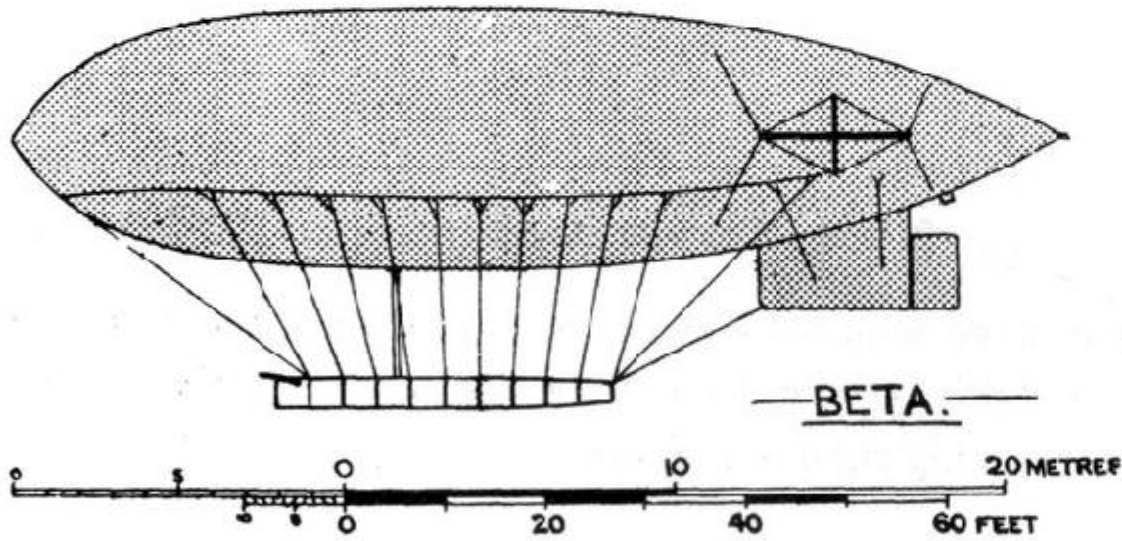

BETA.

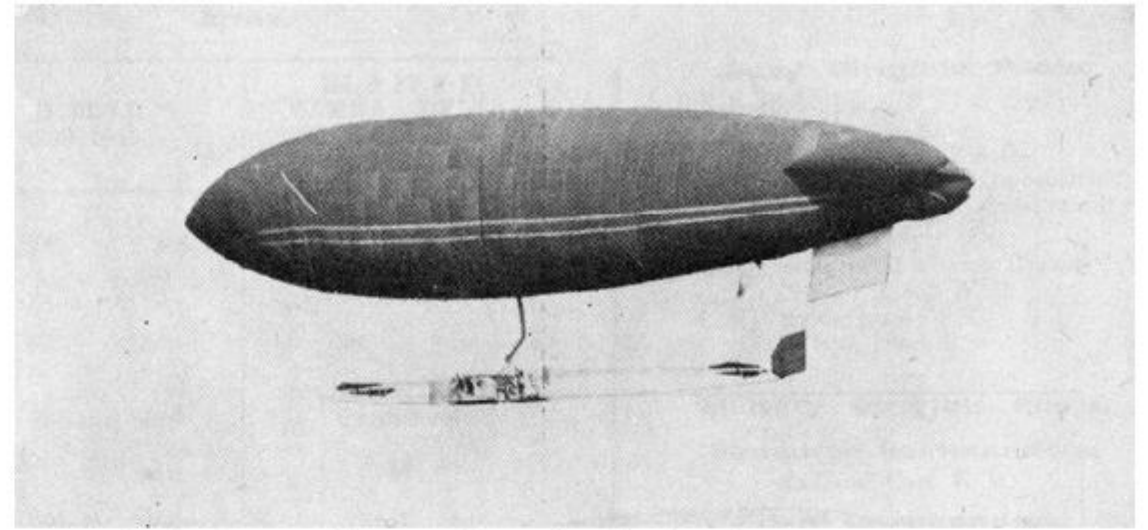

Gamma (Delta the same, but a smaller and enclosed car).

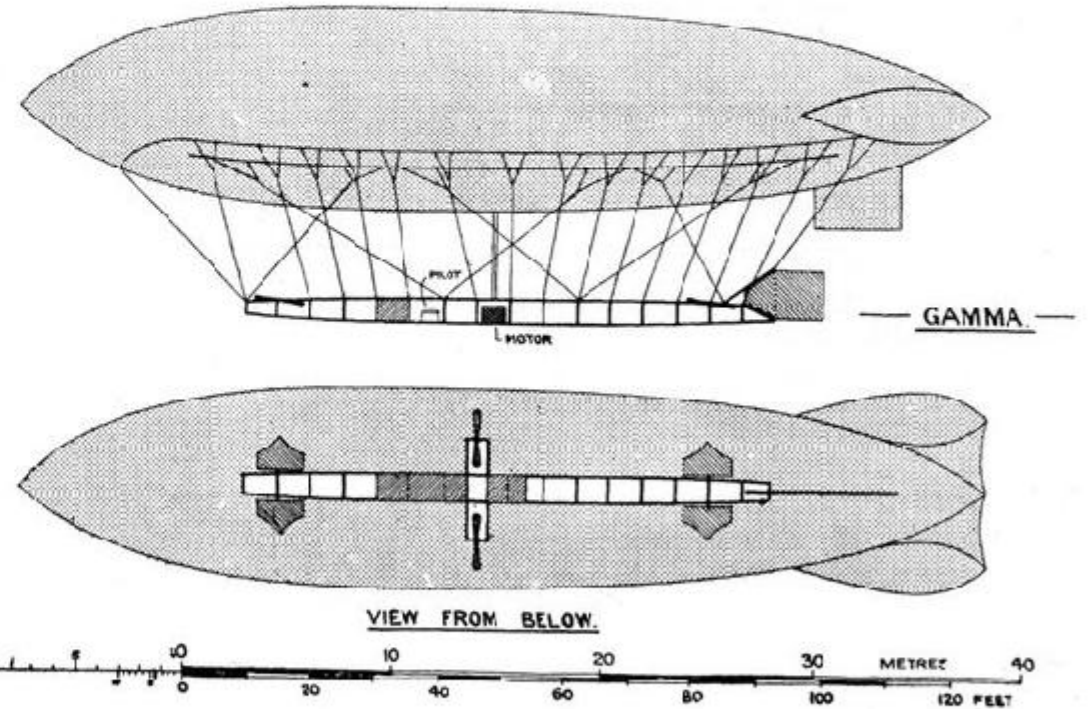

GAMMA.

## BRITISH COLONIAL AIRCRAFT.

### AUSTRALIAN.

#### Military Aviation.

In January, 1913, the Australian Flying Corps was instituted, as a part of the citizen forces. During 1913, about £5,600 is to be spent.

The force is to consist ultimately of 4 officers, 7 warrant officers and sergeants, 32 mechanics.

The school is at Duntroon. Course includes—mechanics of the aeroplane, aerial motors, meteorology, aerial navigation by compass, aerial photography, signalling, etc. Mr. Harrison is in command with Lieut. H. Petre as assistant.

#### Australian Aviators.

Banks, R. C.  
Busteed, H.  
Duigan, J. R.  
Hammond, J. J.  
Harrison  
+Hart  
+Lindsay, C.  
Petre, H.  
Pickles  
Watts

+ = killed.

#### Private Aeroplanes.

J. R. Duigan has built an aeroplane of his own design.

### NEW ZEALAND.

Nothing doing worth mention. One *Bleriot*, 80 h.p., presented 1913 by the *Standard*, London.

## CANADIAN.

#### Aerial Societies.

Aeronautical Society of Canada, c/o. M. P. Logan, 99 Gloucester Street, Toronto  
McGill Aviation Club, McGill University, Montreal  
Oshawa, Ontario Ae. C.

*Note.*—Owing to the fact that the late Aerial Experiment Association was half Canadian and half U.S.A., it is difficult to draw a very clear dividing line between Canadian and U.S. aviators or machines. Thus, one given here is partly U.S.A., while at least one U.S. machine may be claimed as "partially Canadian."

#### AVIATORS.—Private.

Bell, Dr. Graham  
McCurdy, J. A. D. (U.S.A. Ae. C. 18)  
McHardy  
Symonds, E. F.  
St. Henry R.

#### Canadian Aeroplanes.

#### GRAHAM-BELL II.

Flights were made by Dr. Graham-Bell in a tetrahedral type, similar to one described in the 1911 edition.

#### McCURDY-WILLARD. Biplane.

**Maximum length**, 26¼ feet (8 m.) **maximum breadth**, 31-1/3 feet (9.50 m.) **supporting surface**, ? sq. feet (? m<sup>2</sup>.)

**Total weight.**—

**Body.**—Central skid in combination with 4 wheels. Triangular body, base of triangle on top. Fuselage entirely enclosed.

**Planes.**—Maximum span, 31-1/3 feet (9.50 m.) Chord, 3½ feet (1 m.) Gap, 5 feet (1.50 m.) Ailerons at trailing edge of wing tips, 6 feet x 2 feet (1.80x0.60 m.)

**Motor.**—

**Speed.**—

**Tractor.**—Diameter, 7¼ feet (2.40 m.) Pitch, 6 feet (1.82 m.)

**Steering.**—Double elevator placed in rear of tail. *Control*, push and pull wheel.

Rudder in rear. *Control*, wheel.

Ailerons. *Control*, turning steering-wheel left or right.

*Remarks.*—See *Aeronautics*, U.S.A., August, 1911.

There has been also the *Baddeck* and other early machines (see 1911 edition), but none of them seem to be in existence at the present time.

## BRITAIN OVERSEAS AEROPLANES.—INDIAN.

Military Aviation.

—A certain number of officers belonging to the Indian Army have qualified as pilots when home on leave, but there is no organised force. One is, however, proposed.

Private Aviation.

—In the past two or three home-made machines appeared, and one or two were imported, but most or all are now extinct.

## SOUTH AFRICA.

Military Aviation.

—Non-existent.

Private Aviation.

—J. Weston is a qualified pilot, but at the outside there are not more than two effective machines in the country.

## BULGARIAN.

In the Balkan War, 1912-13, Bulgaria hastily organised an aviation corps. This, though necessarily lacking in military organisation, proved very useful on several occasions.

At the end of March, 1913, the aeroplanes effective included 6 *Bristol* monos.; one 70 h.p. *Bleriot XXI*; 2 *Bleriot XI bis* (captured from the Turks); also some half-dozen or more miscellaneous machines temporarily hired.

**Military Aviators.**—The principal are Lieuts. Milkoff, Taraxchieff and Petroff.

A number of other officers in various stages of training.

## CENTRAL AMERICAN.

**General Note.**—Nicaragua and S. Domingo have both purchased one or two aeroplanes for their military forces: but nothing appears to have been done with them.

## CHILIAN.

**Aviator.**—Edwards, Emilio. Sanchez Besa is a Chilian, but resides in Paris (see France).

**Military Aviation.**—In 1912, a commencement was made and one 80 h.p. *Deperdussin* purchased. Other machines are now on order.

## CHINESE.

## DANISH.

### AVIATORS.

Lee, Y. L. (British Ae.C. 148)  
Tsai Tao Prince

### Military Aviation.

In March, 1913, orders were placed for six 80 h.p. *Caudrons*, also for six 50 h.p., and a decision arrived at gradually to acquire a force of 700 aeroplanes, but very little has actually been done to date.

### Aerial Societies:—



Danske Aeronautiske Selskab, 34 Amaliegade, Copenhagen.

### **Aerial Journals:—**

*None*; but *Motor* (3 Bredgade, Mezz, Copenhagen) deals with aerial matters.

### **Flying Grounds:—**

Klampenborg, Copenhagen.  
Skandinavisk Aërodrom.

### **Army Aeroplanes.**

In 1911 there was an Antoinette. Nothing done since.

### **AVIATORS.**

Military.

Ullitz, Kapt.

Private.

Arntzen, Dr.  
Christiansen, S.  
Ellerhammer  
Folmes, Hansen  
Maltke, Count  
Nervoe, A.  
Svendsen, R.  
Thorup, K.

## **DUTCH.**

(Revised by I. SCHIERE, Aeronautical Engineer and Librarian of the Dutch Ae. C.)

### **Aerial Societies:—**

Haagsche Proefvliegtuig Club (3e V.d. Boschstreet 20, The Hague).  
Nederlandsche Vereeniging voor Luchtvaart (Nassau Zuilensteinstraat, 10, The Hague). (Ae. C.)  
Rotterdamsche Model Aero Club (Rochussenstreet 229b, Rotterdam).

Colonial:

Nederlandsche Indische Vereeniging voor Luchtvaart.

### **Aerial Journals:—**

*De Luchtvaart* (Ged Onde-Gracht, 141, Haarlem). Fortnightly.  
*Avia*, Wynbrugstraat 13, Rotterdam. Fortnightly.

### **Flying Grounds:—**

**Breda-Gilske-Rijen.**—6 hangars.  
**Soesterberg.**—20 hangars.

### **Army Aeroplanes.**

Up to the end of 1911 there were none, though some officers had their own private ones (*H. Farman's* mostly).

At end of 1912.

2 monos. *Deperdussin* (for Java).  
1 biplane. *De Brouchére* (for Java).

### **AVIATORS.**

(The number against any name is, unless otherwise stated the Ae. C. Nederlandsche pilot certificate number.)

To end of 1911.

## Military.

Bakker, H. Yandrig  
Labouchere, Lieut. J.  
Meel, Lieut. Van  
Poorton, Lieut. H. ter  
Versreegh, Lt, W. C. J.

## Private.

Bahle, F. K.  
Boerlage, M.  
Burgh, Van der  
Fokker, A. H. G.  
Hilgers, J. W. E. L.  
Konings, L.  
Koolhoven (1)  
Küller, G. P. (2)  
Lutge, F. (4) (323, F.)  
Mulder, A.  
Riemsdyk, Van F. (5)  
Ryk, Madame Bde.  
Wynmalen, H. (6) (208, F.)

The following Dutch aviator has been killed:

1911.  
Van Maasdyck, C. (130, Ae. C. F.)

## DUTCH AEROPLANES.

### DE BROUCKERE. Biplane.

*H. Farman* type. Details, *De Luchtvaart*, No. 8, 1911.

### FOKKER. Monoplane.

Anthony Fokker, of Haarlem. In early 1912 flew at Breda.

### MONNIER-HARPER. Monoplane.

(O.P.I.I.) Generally *Bleriot* type. Built 1911.

### VAN DEN BURG. Monoplane.

Early in 1912 was flying at Johannisthal, Germany.

### VREEDENBURGH. Monoplane.

(O.P.I.I.) Blend of *Bleriot* and *Antoinette*. Motor, 75 h.p. Miesse. Completed December, 1909.



Fokker. Monoplane.

**FOKKER. Monoplane.**

(See Germany for details.) Firm now established in Germany.

**DUTCH DIRIGIBLES.**

**Military.**

**DUINDIGT. Non-rigid.**

(Zodiac make.)

**Length**, 111½ feet (34 m.) **diameter**, 22½ feet (6.80 m.) **capacity**, 31,785 c. feet (900 m<sup>3</sup>.)

**Motor**.—18 h.p.

*Remarks*.—Small edition of *Zodiac III*. (See France.)

## FRENCH.

(Special French Editor.)

### Aerial Societies:—

Aero Club de France.  
Academie Aeronautique de France.  
Aeronautique Club de France.  
Société des Aëronautes du Siège.  
Aero Club du Sud Ouest.  
Aero Club du Rhone.  
Aero Club du Nord.  
La Ligue Aerienne du Sud.  
Société Francaise de Navigation Aérienne.  
Société d'encouragement à l'Aviation.  
(*Full list of clubs next page.*)

### Aerial Journals:—

L'Aerophile.  
L'Aero.  
L'Aeronaute.  
Aerostat (Bulletin Aeronautique).  
Aerostat (Academie d'Aerostation).  
Revue de l'Aerostation.  
Le Ballon.  
L'Aerostation.  
L'Aeronautique.  
Bulletin Aeronautique.  
Encyclopediede l'Aviation.  
La Ligue Nationale Aerienne.  
Revue de l'Aviation.  
L'Aeromécanique.

### Principal Flying Grounds:

**Antibes.**—Hanriot school.  
Beauce.

**Betheny.**—Sommer school. **Deperdussin School.**

**Buc.**—M. Farman school.

Buoy.

**Chalons.**—Sommer school.

**Chalais-Mendon.** (Military)

**Chatres.**—Savary school.

**Cran,** Marseilles.

**Crotoy.**—Caudron school.

**Croix d'Hins,** Bordeaux (Aer. Lig. du Sud.) Area 6 km. Track. Free sheds.

**Corbeaulieu** pres. Compregne.—Doutre school.

**Etampes.**—Bleriot school. Farman school.

Grand Camp, Lyons.

**Issy les Moulineaux.**—Astra school

**Juan-le-Pias.**—Paulhan aquaplane school.

**Juvisy,** near Paris.—Aerodrome. Caudron school. Goupy school.

**La Brayelle,** Douai.—Breguet school.

Da motte Brueil dans L'Oise.

**Le Bourget,** Paris.—100 sheds.

Le Mans.

Moisson.

**Mourmelon.**—Voisin school.

Napante.

**Nice.**—Small and rough surface.

**Pau.**—Bleriot school.

**Reims.**—Aerodrome.

St. Cyr.

**Villacoublay,** Paris.—Breguet, Nieuport and Astra schools.

# FRENCH AEROPLANES.

## Military Aviation.

In February, 1912, the then total of 208 effective aeroplanes were divided into "squadillas" consisting of eight aeroplanes; attached to these eleven or twelve motor cars, one traction car and one fast car, also a repairing car and repairing van.

It was then estimated that at the end of 1912, 344 aeroplanes would be available for service.

The estimated *personnel* was provisionally fixed at 234 officer pilots, 210 scouts, 42 mechanics, 110 officers, 1,600 corporals or sappers and 550 privates.

Approximately £880,000 was spent in aviation during 1912, and £1,000,000 was estimated for future years.

The French military aviation centres are all upon somewhat the same footing as fortresses, and the greater part of the work comes under the head of "confidential." The principal school is at St. Cyr, which was specially selected because the ground is rough and mostly covered with small shrubs: it being held important to train officers from the first to rise and land on ground similar to that most likely to be found in war time. Each station is supplied with large portable wooden-framed hangars covered with canvas. These can be rapidly taken to pieces and re-erected. Each station is supplied with its own special motor transport.

All military machines are provided with a compass and map case in front of the pilot and sketching apparatus in front of the observer.

Although a few non-commissioned officers have been taught flying, the organization only contemplates the employment of commissioned officers as pilots. The age limit is 38.

On April 16th, 1913, the flying corps was modified. The principal features of the corps as now existing are as follows:—

## Establishments.

1. Schools.
2. Special establishments, dealing with purchase, construction, and big repairs.
3. *Directions*. Administration of *material*.
4. Depots. A species of dockyards dealing with minor repairs, etc.

## Administration.

There are three main groups, each commanded by a colonel. Each group consists of dirigibles and aeroplane "escadrilles," and is fully equipped with establishments, etc. The three centres are:—

1. Versailles.
2. Reims.
3. Lyon.

## General.

All squadron units are made up of machines of the same make and power. Pilots are detailed as required to any particular unit, and liable to transfer from one to another, though in practice such transfers are rare.

## Army Aeroplanes.

During 1912 nearly 500 machines were delivered to the Army, but a great many old machines have been scrapped. At the end of March, 1913, the force stood at 421 effective for war machines, plus an uncertain number of school machines and obsoletes.

About one-third or more of the effective aeroplanes were *Farman*s. The rest consisted of all leading French types, proportionated more or less to the productive capacity of these firms. Also certain other makes experimental.

## Navy Aviation.

The Navy section of French military aviation is still in the "being formed" process. No data are yet available as to the ultimate force to be provided. At present the number of effective war machines is small. It is made up of hydro-avions of the following types:—*Astra*, *Borel*, *Breguet*, *Caudron*, *Deperdussin*, *Donnet-Leveque*, *Farman*, *Paulhan-Curtiss*, *Sanchez-Besa*, the total at end of March, 1913, being well under 20. There are also two special *Bleriot* type fitted with floats, which carry 330 lbs of explosive, are fitted with wireless, have a speed of 140 km.p.h. (85 m.p.h.), and a radius of about 600 miles (1,000 km.)

## PRINCIPAL FRENCH ARMY AND NAVY AVIATORS.

(In each case the number against each name is, unless otherwise stated, the Ae. C. French certificate pilot number.)

## Army.

Abadie, Sous Officier  
Acevedo, Lieut. (740)  
Acquaviva, Lieut. Paul V. (68)  
Aiguillon, Lt. R.d' (308)  
Aubry, Lieut.  
Balensi, Capt. Albert (173)  
Bares, Capt. (543)  
Basset, Lieut. Paul (145)  
Battini, Lieut. G. (508)  
Baugnies, Lt. J. B. E. (193)  
Beatrix, Sous Officier  
Bellemois, Lieut. G. (546)  
Bellenger, Capt. M. (45)  
Berni, Lieut. (760)  
Biard, Capt. G. M. (261)  
Bihan, Lieut.  
Binda, Lieut. Louis (232)  
Blard, Lieut. (460)  
Bobillier, Lieut.  
Boerner, Lieut.  
Boissonas, Lieut. (443)  
Bon, Lieut.  
Boncour, Lieut. (478)  
Bonnier, Lieut. (478)  
Bonnier, General (137)  
Boucher, Lieut.  
Bousnuet, Lieut. P. (295)  
Breley, Lieut.  
Brenot, Capt.  
Brouchard, Lieut.  
Brugiere, Lt.  
Brule, Lieut. (436)  
Bruncher, Lieut.  
Burgeat, Capt. M. (44)  
Cameran, Lieut. F. (33)  
Camine, Capt.  
Campagne, Lieut. (782)  
Casse, Capt. (415)  
Chabert, Lieut.  
Charoux, Sous Officier  
Chavenac, Lieut. E. (551)  
Cheutin, Lt. E. J. (233)

Cheveau, Lieut. R. (132)  
Clavenad, Lieut. P. (294)  
Clerc, Lieut. (465)  
Clolus, Commdt. G. (97)  
Couret, Lieut.  
Coville, Capt.  
D'Abrantes, Lieut.  
D'Aquillon, Lieut.  
De Beruis, Lieut.  
De Caumont, Capt.  
De Chanac Lanzac, Capt.  
De Geyer, Lieut.  
De Gorge, Lieut. (805)  
De Goys, Capt.  
De Lafargue (417)  
De L'Estrade, Lieut.  
De Rose, Lieut. P. (477)  
Destace, Capt.  
Destouches, Capt.  
Devarenne, Lieut.  
Devaulx, Lieut. R. (158)  
De Ville d'Avray, Lieut.  
Didier, Sous Officier (765)  
Do-Ird, Lieut.  
Drevet, Sous Officier (753)  
Duparquet, Capt.  
Duperron, Capt. (196)  
Dupin, Lieut.  
Eteve, Capt. A. (89)  
Erstorac, Capt.  
Felix, Capt. J. (270)  
Fequant, Lieut. A. (63)  
Fequant, Lieut. P. (340)  
Fierstein, Sous Officier  
Francezon, E. (410)  
Foirelline, Lieut.  
Garnier, Lieut. (305)  
Garnier, Lt. (826)  
Gastringer, Lieut.  
Gaubert, Lieut. E. (313)  
Germain, Lieut.  
Girard, Lieut. J. (197)  
Gironde, Lt. A. de  
Godefroy, Sous Officier (583)

Gouin, Lt. M. E. R. (348)  
Gourlez, Lieut. (521)  
Grezaud, S.-Lt. P. (265)  
Grailly, Lieut. (399)  
Gronier, Lieut. J. (138)  
Grandjean, Sapper  
Guibert, Lieut.  
Guiton, Sous Officier  
Hable, Sous-Lt. A. L. (257)  
Hugoni, Capt. E. (165)  
Hanouille, Lieut.  
Henequin, Lieut.  
Henri, Lieut. (497)  
Herli, S.-Lt. (257)  
Hurard, Sous Officier  
Issartier (531)  
Jacquet, Lieut.  
Joly, Lieut. F. (341)  
Jost, Lieut. R. G. (264)  
Kass, Capt.  
Langardt, Lieut.  
Laurent, Sous Officier (246)  
Le Beau, Capt.  
Le Bleu, Lieut.  
Lelievre, Lieut. E. (522)  
Lemasson, Lieut. (506)  
Le Mauget, Capt.  
Letheux, Lieut. G. (142)  
Letort, Sapper (170)  
Letourneur, Lieut.  
Lucca, Lieut. D. (154)  
Ludmann, Lieut. G. (255)  
Lussigny, Lieut.  
Machin, Lieut.  
Mailfert, Lieut. F. (146)  
Maillois, Lieut. J. (131)  
Malherbe, Lt. de (334)  
Maneyrol, Lieut.  
Manoha, Lt.  
Marc, Lt.  
Marconnet, Capt. (90)  
Marie, Capt. Felix (80)  
Marlin, Lieut.  
Marmies, Lieut.

Marty, Sous Officier (816)  
Massol, Lieut.  
Mauger, Lieut.  
Maurice, Lieut.  
Mazac, Lieut. (592)  
Migaud, Lieut. G. (501)  
Morel, Sous-Lt. P. (262)  
Morlaye, Lieut. la  
Mouchard, Lieut.  
Negre, Capt.  
Nicaud, Lieut.  
Nogues, Capt. (114)  
Normand, Lieut. F. (314)  
Pelloux, Sous-Lt. M. (346)  
Peraldi, Lieut.  
Peretti, Sous Officier  
Pierre, Lieut.  
Ponchet, Lieut.  
Prat, Lieut.  
Precardin, Lieut.  
Princetau, Lieut.  
Postulat, Sergt.  
Quennehen, Sous Officier  
Ragot, Lieut.  
Remy, Lieut. H. C. (143)  
Reynard, Lieut. (668)  
Rimbert, Lieut.  
Rocca-Serra, Lieut.  
Rochette, Lieut. J. (564)  
Rolland, Lieut. M. E. (545)  
Ronin, Lieut.  
Rougerie, Lieut.  
Sauleillon, Lt. A. (674)  
Saunier, Lieut. G. (153)  
Seguin, Sapper (528)  
Sevelle, Lieut. (747)  
Silvestre, Lieut. (599)  
Sido, Capt. Marie (65)  
Sourdeau, Lieut. A. (474)  
Soulielani, Lieut.  
Thomas, Lieut. (846)  
Thomas, R. (116)  
Touzet, E. (485)  
Tretane, Lieut.

Tricornot de Rose, Lt. de (330)  
Vandamone, Lieut. (535)  
Van de Vaero, Lt. (491)  
Vandine, Lieut.  
Varcin, Lieut.  
Vaudein, Lieut.  
Verdier, Sous Officier (538)  
Vibra, Lieut.  
Vigne, Lt. Henri (315)  
Vinda, Lieut.  
Vitra-Rougerie, Lieut.  
Vocayeau, Lieut.  
Vogoya, Capt.  
Vuilliereme, Lt. L. (174)  
Watteau, Lieut.  
Willemenz, Lieut. (759)  
Yence, Lieut. R, (220)

### Naval.

Byasson, Lt. de V. (175)  
Cayla, Lieut. (458)  
Conneau, Lieut. (322) "Beaumont"  
Davelny, Comdt.  
Delage, Lieut. G. (219)  
Fournier, Lieut.  
Hauteville, Lieut. (247)  
Lafon, Lt. (194)  
Leve, Lieut. (243)  
Parasa, Lieut. (179)  
Reymond, Lieut. (206)

## FRENCH AEROPLANES—PRIVATE.

### Private Aeroplanes.

The total number of machines built in France during 1912 has been estimated at about 1,500. This includes military as well as private machines, also machines exported, and appears to be unduly generous even so. The actual total of machines commenced and completed in 1912 is nearer 1,000.

The number of private aeroplanes—excluding demonstration and school machines is small.

### PRIVATE AVIATORS

(brevets to end of 1911).

(In each case the number against each name is, unless otherwise stated, the Ae. C. French certificate pilot number.)

Algrin, Rene (252)  
Allard, M. (480)  
Alincourt (488)  
Andre, C. (192)  
Aubrun (21)  
Bachot, A. (271)  
Baeder, F. de (107)  
Bague, E. (337)  
Balliod, Louis (236)  
Balaye, A. (275)  
Balsan, Jacques (22)  
Baratoux, Marcel (49)  
Barbotte, Ernest (268)  
Barra, Franck (171)  
Barrier, A. (64)  
Banier, Rene (64)  
Bathiat, Georges (237)  
Bathiat, Leon (110)  
Beard, Pierre (276)  
Beaud, Edouard (150)  
Becue, Jean F. (263)  
Bellier, Albert (297)  
Bellot, Andre (317)  
Benoist, Jean (369)  
Bergognie, Charles (373)  
Bernard, A. (505)



Berlot, Henri J. (450)  
Biard, Desire J. (460)  
Bielovucic, Jean (87)  
Bill, Henri (205)  
Blanchet, Georges (244)  
Bleriot, Louis (1)  
Blondeau, Gustave (101)  
Bobba, Andre (309)  
Boillot, Geo. (395)  
Boissounas, L. (443)  
Boise de Courcenay, Comte (283)  
Boivin, Albert (248)  
Bonzon, Maurice (355)  
Bouvier, Andre (120)  
Boyer, Louis (303)  
Bregi, Henry (26)  
Breguet, Louis (52)  
Bresson, Georges (280)  
Briancon, Lucien (277)  
Briey, F. de (492)  
Brindejonc des Moulinais (449)  
Bruneau de Laborie, E. (67)  
Bunau-Varilla, E. (16)  
Busson, Guillaume (121)  
Caille, Albert (200)  
Caramanlaki, A. (761)  
Carles, Fernand (362)  
Carlin, L. V. (554)  
Caudron, Rene (180)  
Cayla, P. (458)  
Chailliey, Henri (63)  
Challe, M. J. (523)  
Champel, Florentin (94)  
Chanteloup, P. (549)  
Chapelle, J. (547)  
Charpentier, Louis (286)  
Chassagne, Jean (160)  
Chausse, P. (519)  
Chaussier, Piere (384)  
Chatain, Marius L. (267)  
Chatain, L. M. L. (296)  
Chateau, Edouard (135)  
Chaunac-Lenzac de (394)  
Chemet, Geo. (159)

Cheuret, Leon (62)  
Cherent, L. (62)  
Chevalier, J. (515)  
Chevalier, Louis (333)  
Chevillard, Maurice (385)  
Chioni, Basile (250)  
Clerc, Paul A. L. (465)  
Clement, M. (108)  
Collardeau, Geo. (393)  
Collieux, M. (85)  
Collin, Georges (279)  
Conard (647)  
Contard, Paul (351)  
Contenet, Henri (447)  
Contour, Ernest (371)  
Contre (657)  
Cordonnier, Robert (221)  
Corso, E. (529)  
Crochon, Andre (43)  
Cronier, Andre M. H. (352)  
Cugnet, Gaston (140)  
Cure, Gaston M. (242)  
Daillens, Jean (119)  
Dancourt, P. H. (520)  
Debener, M. (562)  
Deletang, Fernand (42)  
Delacroix, Maurice (452)  
Delagrang, Robert (366)  
De La Roche, Mde. (36)  
Deloche, R. D. (526)  
Denis, Auguste (380)  
Deroy, Francis (374)  
Derry, Leon (254)  
Deruissy, Andre (376)  
Despres, E. M. L. (527)  
Deschamps de Bois, Hébert (461)  
Didier, A. (77)  
Divetaïn, Pierre (466)  
Driancourt, M. L. (525)  
Dubonnet, Emile (47)  
Duoweneau (456)  
Dufour, Jean M. R. (457)  
Dufour, Jean (96)  
Dufour, Louis (185)

Duval, E. (118)  
Duval, Emile (118)  
Echeman, P. M. (466)  
Esnault-Pelterie, R. (4)  
Espanet, Dr. G. (532)  
Farman, Henry (5)  
Farman, Maurice (6)  
Fiorellimo, Louis (369)  
Florencie, Jean (201)  
Fournie, J. P. S. (502)  
Frantz, Joseph (363)  
Francq, Baron de (481)  
Frey, Alfred (48)  
Frey, Andre (93)  
Froussart, Ernest (350)  
Frugier, Leon (378)  
Gaget, Joseph (335)  
Gaillard, J. O. C. (504)  
Gallie, Fernand (343)  
Gardey, M. (482)  
Garros, Roland (147)  
Garsonnin, L. (555)  
Gastinger, Edouard M. (455)  
Gassnier, René (39)  
Gassier, Marcel (392)  
Gasnier, Pierre (391)  
Gaudart, Louis (228)  
Gaulard, Charles (302)  
Gautheron, Louis (449)  
Gaye, Georges (251)  
Gibert, Louis (92)  
Gilbert, Eugene (240)  
Giraud, Etienne (493)  
Glorieux, Leon (188)  
Gobe, Armand (102)  
Gobron, Jean (7)  
Goffin, Marcel (284)  
Gouguenheim, P. (388)  
Goux, Jules (398)  
Gournay, Henri (186)  
Goys de Mereyrac, Louis (354)  
Grandjean, E. C. H. (469)  
Grandseigne, R. (360)  
Granel, Marcel (117)

Grellet, Alexis (370)  
Gressard, M. (725)  
Gue, Albert (216)  
Guerre, Henri (444)  
Guidard, V. P. (487)  
Guilband, C. J. (518)  
Guillemard, T. (445)  
Guillaume, C. (651)  
Hainaux, Marcel R. (239)  
Hanriot, Marcel R. (239)  
Hanriot, Rene (368)  
Herbster, Maurice (41)  
Herveu, Mlle. Jane (318)  
Hesne, Paul (113)  
Houlette, Andre (367)  
Jacquemart, G. C. (464)  
Jamblez, Paul A. (266)  
Janoir, L. (553)  
Joliot, André (202)  
Joly, C. E. M. (530)  
Julleriot, Henry (61)  
Junod, Auguste (253)  
Kauffman, Paul (198)  
Kergariou, Engard de (503)  
Kieffer, C. E. (372)  
Kummerling, A. (291)  
Koechlin, Jean P. (203)  
Kuhling, Paul L. (136)  
Labouchere, Rene (86)  
Labouret, Rene (222)  
Lacombe, P. (534)  
Ladougne, Emile (81)  
Lafarge, Henri (278)  
Lajous, Francois, A. (463)  
Lambert, Comte de (8)  
Langhe, Armand de (204)  
Lastours, H. R. de (552)  
Larfinty-Tholosan, Marquis Jules (468)  
Laroche, Mme. Raymonde (36)  
Latzel, J. (700)  
Leblanc, Alfred (17)  
Lecomte, Henri (320)  
Legagneux, Georges (55)  
Le Lasseur de Ranzay, G. (479)

Lemartin, Theodore (249)  
Lenfant, Louis (386)  
Leouet, B. L. (485)  
Leprince, P. (494)  
Lesire, Eugene (176)  
Lesseps, Jacques de (27)  
Leyat, Marcel (364)  
Lieutard, H. (497)  
Liger, A. (573)  
Lombardi, Henri (241)  
Loridan, Marcel (224)  
Magnan, Leon (379)  
Magneval, Gabriel (359)  
Mahieu, Georges E. (123)  
Mallet, J. A. P. (490)  
Mamet, Julien (18)  
Marchal, Anselem (328)  
Maron, P. H. (495)  
Marquezy, Rene (238)  
Martin, Edouard (365)  
Martin, Xavier (162)  
Martinet, Robert (78)  
Marvingt, Marie (281)  
Mauvais, Jean (144)  
Metrot, Rene (19)  
Meyer, Jules M. (229)  
Mignot, Robert (76)  
Miltgen, Paul (339)  
Moineau, R. L. (554)  
Molla, Henri (172)  
Montalent, O. de (509)  
Montjou, Guy de (446)  
Mollien, Elie A. (57)  
Molon, Leon (25)  
Molon, Louis (234)  
Molon, Lucien (235)  
Montigny, Alfred de (69)  
Morane, Leon F. (54)  
Morelle, Edmond (35)  
Morel, P. F. (524)  
Morin, Roger (306)  
Mouthier, Louis (157)  
Mousnier, Yvon (454)  
Niel, Albert (104)

Niel, Mme. Marthe (226)  
Nissole, Edouard (383)  
Noe, A. G. M. (498)  
Noel, Andre (122)  
Obre, Emile (148)  
Ors, Jean (382)  
Orus, Maurice (256)  
Osmon, Geo. (361)  
Paillette, Marcel (99)  
Paillole, E. C. L. (556)  
Palade, Antoine (387)  
Pallier, Mdle.  
Parent, Francois (189)  
Paris-Leclerc, Max (190)  
Partiot, G. (516)  
Pascal, Ferdinand (301)  
Paul, Ernest (91)  
Paulhan, Louis (10)  
Pequet, Henri (88)  
Perin, Albert (161)  
Perreyon, Edmond (311)  
Perrigot, J. (499)  
Picard, Pierre (174)  
Planchet, Edmond (319)  
Poillot (182)  
Pommier, Martin (400)  
Porcheron, L. A. (471)  
Pouleriguen, F. (349)  
Poumet (576)  
Pourpe, Marc  
Pourpe, M. M. E. A. (560)  
Prevost, M. (475)  
Prevoteau, G. (507)  
Prier, Pierre (169)  
Raoblt, Jean (386)  
Reimbert, Ernest (375)  
Reichert, Henri (377)  
Renaux, Eugene (139)  
Renaud de la Fregeolierie (396)  
Rey, P. A. P. (517)  
Reymond, Senator  
Richet, A. (537)  
Rigal, Victor (60)  
Rivolier, Jean (381)

Robillard, G. de (184)  
 Robinet, J. (476)  
 Romance, F. de (288)  
 Rougier, Henry (11)  
 Ruby, F. L. (514)  
 Ruchonnet (127)  
 Sallard, H. (794)  
 Sallenave, Henru (66)  
 Savary, Robert (112)  
 Schlumberger, M. (316)  
 Sée, Raymond (187)  
 Servies, Jules (218)  
 Simon, Rene (177)  
 Sommer, Roger (29)  
 Tabateau, Maurice (128)  
 Taurin, Andre (84)  
 Tetard, Maurice (79)  
 Thieulin, Joseph (459)  
 Tissandier, Paul (13)  
 Tixier, Henri (397)  
 Toussin, Rene (56)  
 Train, Emile Louis (167)  
 Vallier, Edmond P. (269)  
 Vallon, Rene (109)  
 Van Gaver, Paul (338)  
 Vasseur, Narcisse (282)  
 Vedrines, Jules (312)  
 Vendrines, E. (536)  
 Verliac, Adrien (129)  
 Vergmault, O. (561)  
 Verrier, Pierre (390)  
 Versepuy, Leon (149)  
 Vialard, Charles (342)  
 Vidart, Rene (133)  
 Villeneuve Trans, Louis de (285)  
 Vimard, E. (484)  
 Visseaux, Henri (217)  
 Vittoz-Gallet, G. (500)  
 Wagner, Louis (83)  
 Walleton, Louis (304)  
 Weiss, H. (73)  
 Wintrebert, Henri (300)  
 Zens, Ernest (28)

The following French aviators have been killed:—

1909.

Ferber, Capt.  
 Lefebvre, E.

1910.

Blanchard (215)  
 Delagrange, Leon (3)  
 Le Blon (38)  
 Poillot (182)

1911.

Byasson, Lt.  
 Camine, Capt.  
 Caumont, Lieut. (156)  
 Carron, Capt.  
 Chotard, Lieut.  
 De Grailly, Lieut.  
 Desparmet, J. (451)  
 Dupuis, Lieut.  
 Gaubert (59)  
 Laffont, A. (111)  
 Lautheau, Lt.  
 Level  
 Liere, Louis  
 Loder, Lt.  
 Madiot, Capt. (106)  
 Mommlin  
 Nieuport, E. (105)  
 Noel  
 Princeteau, Lt. (331)  
 Ruchonnet  
 Tarron, Capt.  
 Vallon, Rene  
 Wachter, C. L. (53)

#### FRENCH PRIVATE AVIATORS, 1912.

Adam-Gironne (818)  
 Arondel, P. (827)

Andenis, C. (788)  
Badet (622)  
Balighant, G. (588)  
Barbarou, M. (702)  
Basano, F. (828)  
Baudrin, E. (609)  
Bedel, R. (668)  
Beatrix, C. (781)  
Benoit, O. (771)  
Benoist, G. (667)  
Bertin, L. (801)  
Blaignan (633)  
Bleu, Le (643)  
Boiteau, G. (833)  
Boerlage (666)  
Bordage, A. (650)  
Boncour (678)  
Boucher, F. (600)  
Borie, A. (803)  
Brocard, A. (770)  
Brodin, E. (838)  
Brouard, E. (807)  
Bruginere, A. (813)  
Cailleaux, A. (617)  
Carreard, G. (779)  
Castellan, E. (639)  
Cavalier, M. (764)  
Caye, M. (672)  
Cerantes, F. (611)  
Chabert, V. (631)  
Chandenier, L. (804)  
Coblyn, L. (735)  
Contre (657)  
Corsini, A. (654)  
Cornier, R. (605)  
Coville, F. (594)  
Couffin, L. (619)  
Dambricourt, J. (773)  
De Beausire de Seyssel (756)  
Debroustelle, P. (806)  
De Chabot, P. (783)  
De Gensac, A. (836)  
De Lareinty Tholozan, H. (822)  
Delacour, J. (602)

Delaunay, P. M. (635)  
Deleraye, M. (790)  
De l'Escaille (791)  
Delmas, M. (837)  
De Marmies, R. (663)  
De Mazurkiewicz, W. C. (707)  
Denhaut, F. (690)  
Des Pres de la Morlais (636)  
De Pontac (596)  
De Reals, R. (686)  
De Ryk (Mme. B.) (652)  
De Segonac, R. (669)  
Desille, L. (581)  
De Vergnette, C. (792)  
De Villepin, O. (832)  
Do Huu, T. (649)  
Drouhet, F. (727)  
Dussot, A. (733)  
Dutertre, C. (748)  
Ecomand, G. (714)  
Ehrmann, L. (646)  
Escot, P. (624)  
Eymien, S. (726)  
Fassin, F. (844)  
Faucompre, L. (814)  
Fleiche, L. (729)  
Foudre, R. (808)  
Foulquier, M. (772)  
Francois, A. (665)  
Galon, S. (613)  
Garros, R. (811)  
Glaize, F. (845)  
Godot, J. (815)  
Grazzioli, A. (687)  
Grasset, A. (800)  
Greppo, J. (676)  
Guerre, P. (730)  
Guillaux, E. (749)  
Hanne, A. (681)  
Helen, E. (586)  
Hembert (662)  
Hurard, J. (757)  
Hustinx, C. (716)  
Irate, G. (655)

Jacquin, A. (582)  
Jailler, L. (682)  
Jeannerod, H. (696)  
Jeansoulin, L. (703)  
Joachim, H. (610)  
Jourjon, R. (841)  
Junquet, P. (621)  
Kormann (789)  
Lambert, A. (618)  
Lanier, P. (684)  
Lantheaume, C. (616)  
Latzel, J. (700)  
Le Bleu, P. (643)  
Leclerc, P. (593)  
Lefebvre, L. (691)  
Lecontellec, H. (810)  
Lenfant, P. (731)  
Lemoine, A. (632)  
Leroy, J. (638)  
Lesne, M. (796)  
Levasseur, J. (743)  
Le Vassor, J. (704)  
Lewis, J. (642)  
Loubignac, L. (793)  
Lumiere, G. (840)  
Madon, G. (595)  
Magnin, L. (648)  
Maicon, A. (695)  
Mandelli, P. (762)  
Mauger, D. (750)  
Malecaze, J. (776)  
Mancarot (710)  
Mazier, L. (634)  
Melin, E. (699)  
Metairie, A. (689)  
Mouroux, J. (724)  
Navarre, A. (584)  
Noel, L. (656)  
Nove-Josseraud (825)  
Olivier, L. (556)  
Pasquier, Baron R. (728)  
Penet, H. (809)  
Pia, G. (829)  
Picard, F. (601)

Poulet, E. (709)  
Radisson, V. (834)  
Raulet, F. (658)  
Richer, H. (607)  
Ridont, R. (817)  
Roussel, L. (659)  
Roux, H. (715)  
Saint-Michel Rivet (604)  
Sallard, H. (794)  
Sauson de Sausal (812)  
Schneegaus, C. (712)  
Senart, J. (661)  
Sensever, H. (580)  
Senougue, A. (823)  
Serant, L. (679)  
Seyrat, J. (830)  
Shigeno, K. (744)  
Soularis, M. (698)  
Soyer, H. (671)  
Testulat, P. (821)  
Thierry de Ville d'Avray (579)  
Thoret, J. (708)  
Tierch, M. (645)  
Tournier, A. (677)  
Trescartes, L. (842)  
Vallet, C. (734)  
Vaudelle, R. (785)  
Vandinck, A. (787)  
Vandal, P. (598)  
Ventre, L. (585)  
Vidal Soler, E. (686)  
Vogoyeau, A. (755)  
Whitehouse, W. (589)  
Zens, P. (675)  
Zorra, L. (653)

**Killed.**

1912.

Barillon (307)  
 Bedell, R.  
 Bernard, Suzanne  
 Boerner, Lieut.  
 Boncour, Lieut.  
 Bressand, Lieut.  
 Chanteriers, Lieut.  
 Dubois, Capt.  
 Ducourneau, Lieut.  
 Etienne, Lieut.

Faure, Capt.  
 Lacour  
 Madiot, Capt. (106)  
 Maguet, Capt. le  
 Nieuport, C.  
 Olivers, G.  
 Peignan, Lieut. A.  
 Poutrin, Lieut.  
 Sevelle, Lieut. H. P.  
 Thiery de Ville d'Avray, Lieut.  
 Thomas, Lieut.  
 Wagner, A.

1913.

Bresson, Lieut.

## FRENCH AEROPLANES.

### A

#### AERIENNE.

L'Aerienne, 25 Quai des Grands Agustins, Paris. Builds to specifications and supplies all parts.

#### ANTOINETTE.

Company has ceased to exist.

#### ASTRA.

"Astra" Soc. de Constructions Aéronautiques, (Anciens Etabs. Surcouf) Soc. An'yme 13 Rue Couchat, Billancourt (Seine). Works: 121-123 Rue de Bellevue, Billancourt. Flying grounds: Issy-les-Molineux Villacoublay (S-&-O). This old established balloon and dirigible firm first took up aviation as French agents for the *Wrights* in 1909. For a time they built *Wrights* with certain modifications, but by 1912, little save the Wright system of warping remained. Capacity: about 100 machines a year.

		Biplane, type C. 1912-13. Wood.	Military biplane type C.M. 1912-13.Wood	Biplane, Type C. 1913. Wood & steel.	Mil. biplane, type C.M. 1913. Wood & steel.	Hydro- biplane, type C.M. 1913. Wood & steel.
Length	feet (m.)	34 (10.40)	36 (10.97)	34 (10.40)	36 (10.97)	32¾ (10)
Span	feet (m.)	41 (12.50)	40½ (12.32)	41 (12.50)	40½ (12.32)	39½ (12)
Area.	sq. feet (m <sup>2</sup> )	519 (48.2)	519 (48.2)	519 (48.2)	519 (48.2)	519 (48.2)
Weight	machine lbs. (kgs.)	1764 (800)	2365 (1073)	...	1411 (640)	1763 (800)
	useful lbs. (kgs.)	661 (300)	882 (400)	...	...	...

Motor	h.p.	50 Renault	75 Renault or 75 Chenu	50 Renault	75 Renault	100 Renault
Speed	max. m.p.h. (km.)	56 (90)	56 (90)	56 (90)	56 (90)	56 (90)
	min. m.p.h. (km.)	...	...	...	...	...
Endurance	hrs.	...	...	...	...	...
Number built during 1912		...	...	...	...	...

*Remarks.*—The 1912-13 and 1913 types differ only in the adoption of metal in the 1913 models, which are consequently considerably lighter.

*General features.*—Warping wings. Fixed tail planes with two elevators in rear. Single rudder. Single tractor geared down 1 to 2. Type C carries 85 litres petrol; type C.M., 137 litres.



Astra. Military "C.M." 1913.

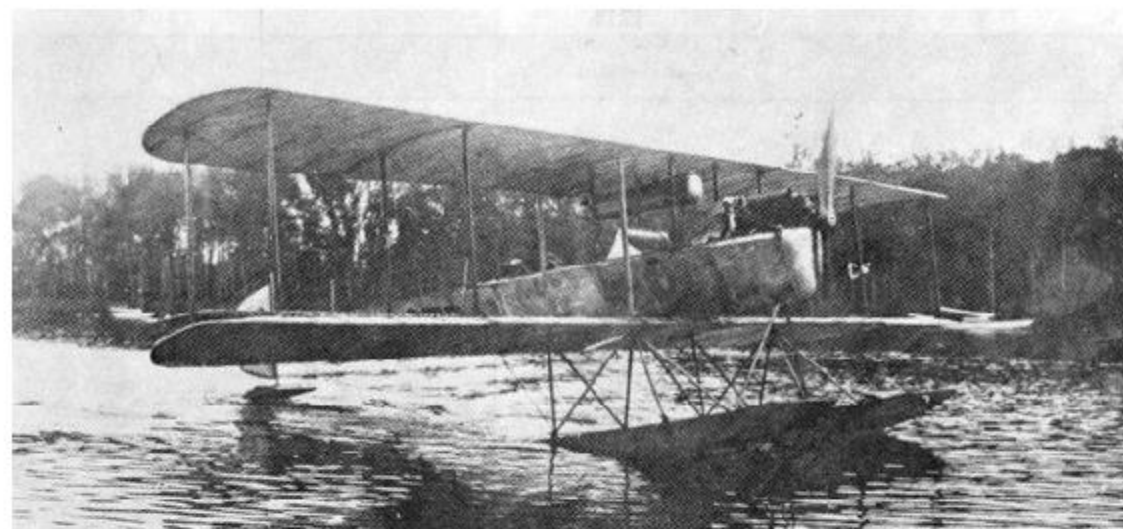

Astra. Hydro-avion, 1913.

**B**

## BERTIN.

L. Bertin, 23 rue de Rocroy, Paris. About 1908 Bertin began building helicopters. The machine below was exhibited in the 1913 Paris Salon.

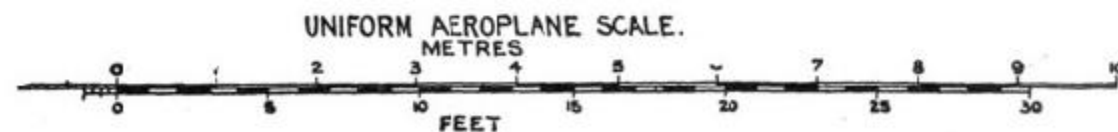

Bertin. Uniform Aeroplane Scale



		1913. Monoplane. 2-seater.
Length	feet (m.)	29 (8.80)
Span	feet (m.)	34 (10.40)
Area	sq. feet (m <sup>2</sup> .)	226 (21)
Weight	machine, lbs. (kgs.)	770 (350)
	useful lbs. (kgs.)	...
Motor	h.p.	100 Bertin
Speed	max m.p.h. (km.)	71 (115)
Number built during 1912		1

Remarks.—Wood and steel construction. On wheels only. Controls: warping and rear elevator.

### BESSON.

Marcel Besson, 24 rue Marbeuf, Paris. Capacity: small. Besson first appeared in 1911 with a tail-first mono. In the Paris Salon, 1913, he exhibited an improved machine along similar lines.

		1913 Canard 2-seater.
Length	feet (m.)	22 (6.70)
Span	feet (m.)	44 (13.40)
Area	sq. feet (m <sup>2</sup> .)	323 (30)
Weight	machine, lbs. (kgs.)	730 (331.2)
	useful (kgs.)	...
Motor	h.p.	70 Gnome
Speed	m.p.h.(km.)	59 (95)
Number built during 1912		1

Remarks.—All steel construction. On wheels and 2 skids. Control: ailerons and front elevator.

### BLERIOT Monoplanes.

L. Bleriot, "Bleriot-Aeronautique," 39, Route de la Révolte, Paris-Levallois. Flying grounds: Buc Etampes and Pau.

L. Bleriot began to experiment in 1906, along Langley lines. By 1909 he was one of the leading French firms; and the first cross Channel flight was made by him.

Details of standard types:—

		XI bis. 2-seater mono. (1911 onward)	XXI. Military side by side 2-seater mono. 1912.	XXVII. Single seat mono. 1912.	XXVIII. Single seater 1913.	XXVIII. 2-seater. 1913.	Monocoque 2-seater 1913.
Length	feet (m)	27-1/3 (8.40)	27¼ (8.24)	28 (8.50)	25 (7.60)	27 (8.20)	...
Span	feet (m)	36 (11)	36 (11)	29½ (9)	29 (8.80)	32 (9.75)	40 (12.25)
Area	sq. ft. (m <sup>2</sup> .)	349 (33)	268 (25)	129 (12)	162 (15)	215 (20)	270 (25)
Weight	unladen, lbs. (kgs)	...	727 (330)	529 (240)	530 (240)	660 (300)	830 (375)
	useful lbs. (kgs.)	...	...	...	286 (129)	550 (250)	...
Motor	h.p.	50 Gnome	70 Gnome	70 Gnome	50 Gnome	70 Gnome	80 Gnome
Speed	max. m.p.h. (km.)	56 (90)	56 (90)	78 (125)	62 (100)	71 (115)	75 (120)
	min. m.p.h. (km.)	...	...	...	...	...	...
Endurance	hrs.	...	...	...	...	...	...
Number built during 1912		...	...	...	...	...	...

Note.—The monos., as usual, are of wood construction; wheels only for landing. Rectangular section bodies. Warping wings, elevator in rear. Chauviere propeller. The monocoque has wood, steel and cork construction. Coque body. Skids to landing chassis. Levasseur propeller. Otherwise as the other monos.

Principal Bleriot flyers are or have been:—Aubrun, Balsan, Bleriot, Busson, Chavez, Cordonnier, Delagrange, Drexel, Efimoff, Gibbs, Hubert, Hamel, Moissant, Paulhan, Prevetau, Prevot, Prier, Radley, Thorup, Tyck, Wienzciers, and many others.

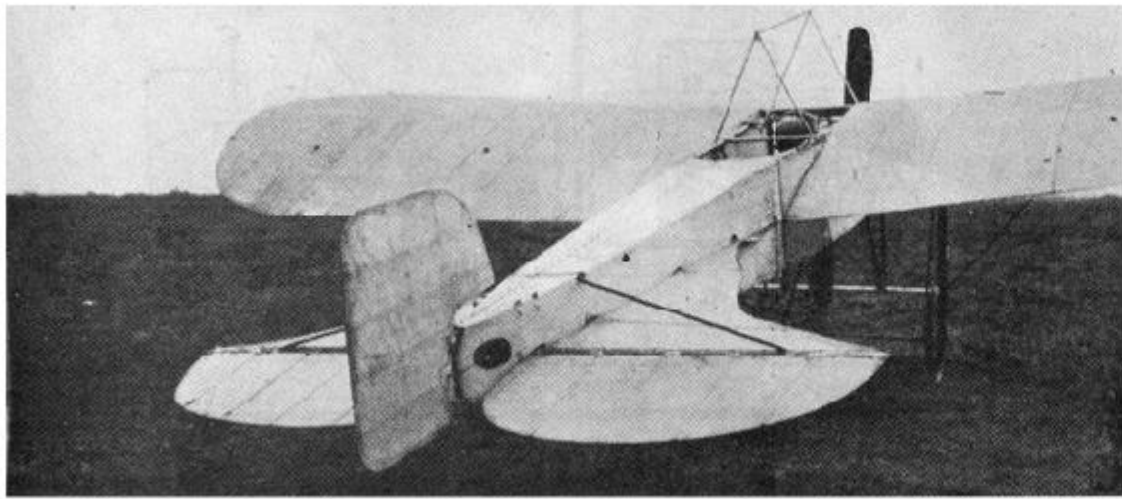

Blériot XI *bis*.

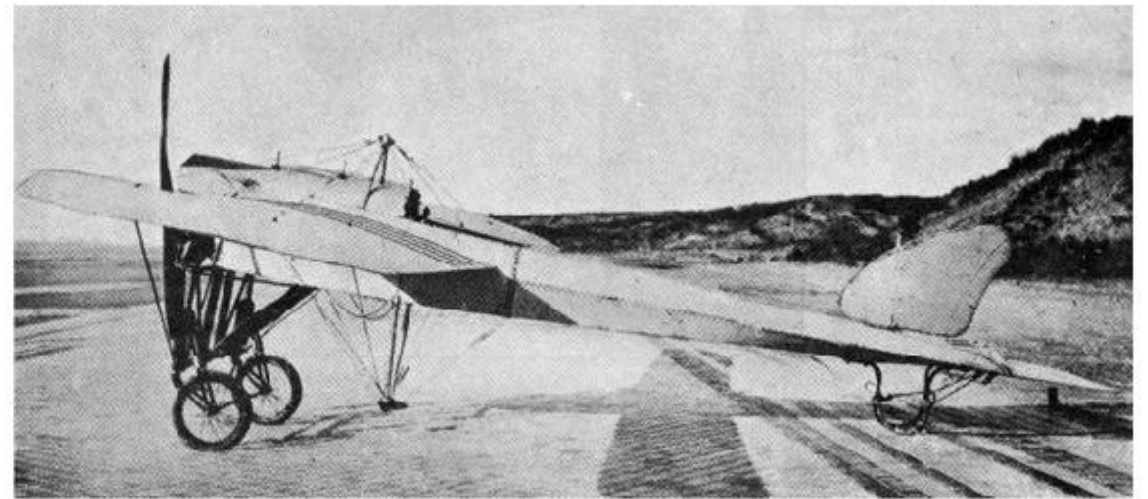

Blériot XXVII.

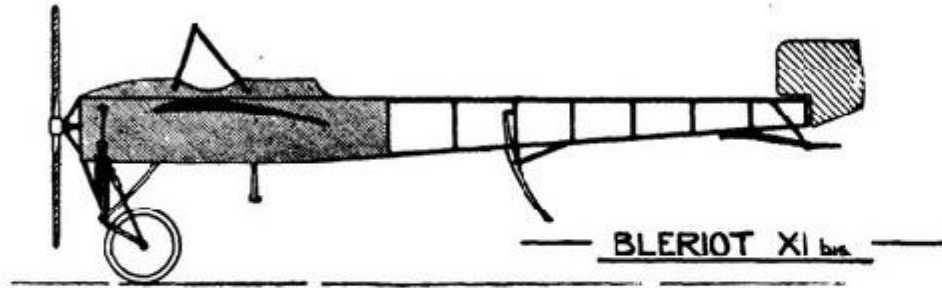

1913 type of XI *bis*.

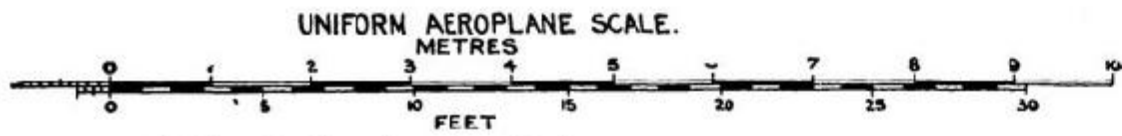

1913 type of XI *bis*. Uniform Aeroplane Scale

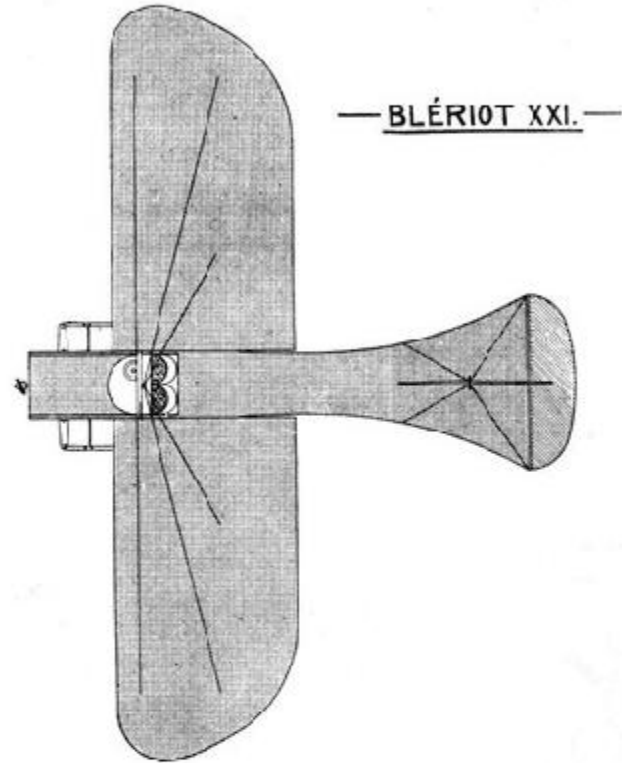
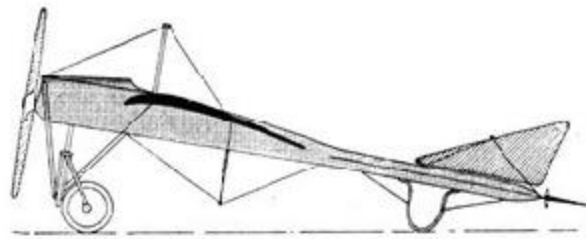

General standard type of *Bleriot* 1912 & 1913. Uniform Aeroplane Scale

**Special types of Bleriotics.**—In addition to the standard machines, Bleriot from time to time produces special machines, of which the best known is the *Limousine*, built for M. Deutsch de la Meurthe, built 1911 and still existing. One or two Canards have also been built, including an armoured military.

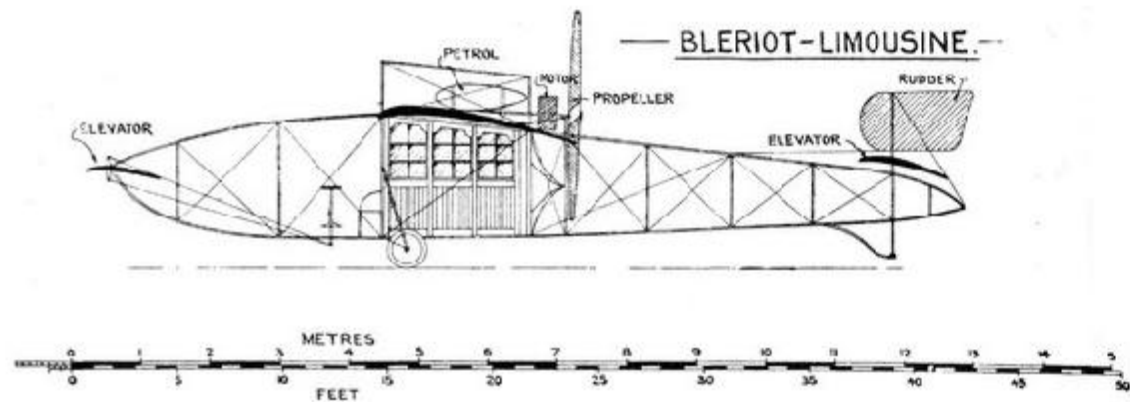

BLERIOT-LIMOUSINE. Uniform Aeroplane Scale

Early in 1913 a special experimental military machine was produced with considerable secrecy.

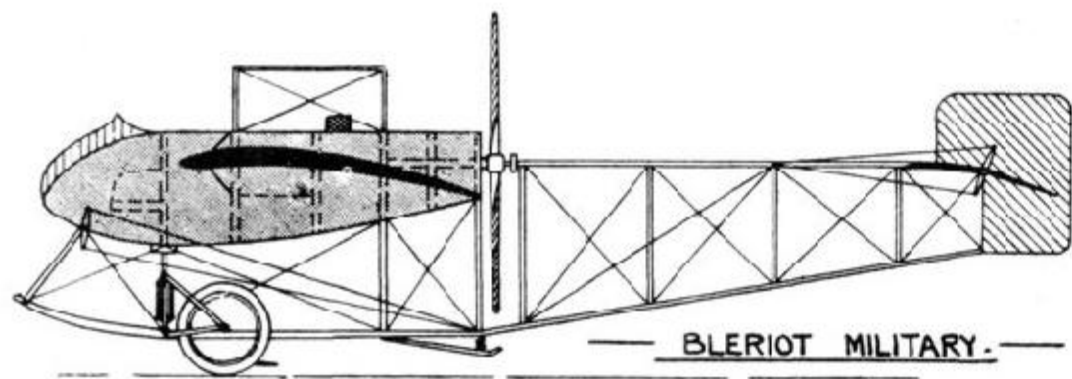

Special 1913 military.

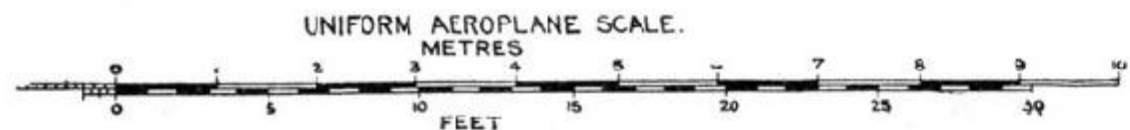

BLERIOT MILITARY. Special 1913 military. Uniform Aeroplane Scale

## BOREL.

G. Borel & Cie, 25 rue Brunel, Paris. Established 1910. Capacity: about 25 machines a year.

Model.	1913. Monoplane.	1913. Monocoque Racer.	1913. Hydro-mono. 2-seater.
Length	22 feet (6.70 m.)	19 feet (5.80 m.)	27 feet (8.30 m.)
Span	30 feet (9.15 m.)	26 feet (8.00 m.)	37 feet (11.25 m.)
Area	152 sq. ft. (14 m <sup>2</sup> .)	116 sq. ft. (11 m <sup>2</sup> .)	237 sq. ft. (22 m <sup>2</sup> .)
Weight total	530 lbs. (240 kgs.)	608 lbs. (276 kgs.)	880 lbs. (399 kgs.)
useful	287 lbs. (130 kgs.)	...	...
Motor	50 Gnome	80 Gnome	80 Gnome
Speed (p.h.)	71 m. (115 km.)	94 m. (150 km.)	62 m. (100 km.)

*Note.*—The monocoque is of wood and steel construction, the others wood only. The monocoque has coque body, the others ordinary rectangular section. Floats of the hydro as illustrated. For the rest the ordinary mono. is practically on the same lines as the 1912. The racer is somewhat on *Deperdussin* lines, but the body is built up inside. No fixed tail. The hydro. is an enlarged edition of the mono. Floats display nothing very original, except that a float under tail is interconnected with the rudder, and that the two front floats are fitted for being rowed. Fitted with a self-starter.

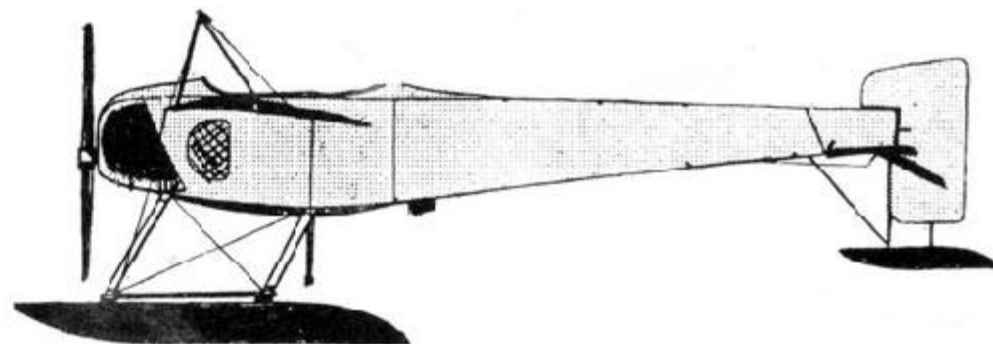

1913 BOREL. Hydro-avion.

*By favour of "Flight."*

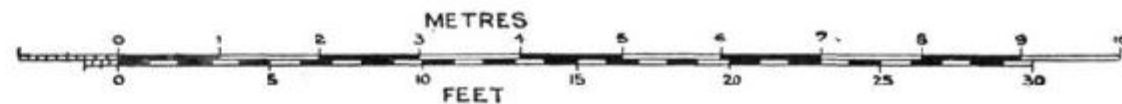

1913 Borel. Hydro-avion. *By favour of "Flight."* Uniform Aeroplane Scale

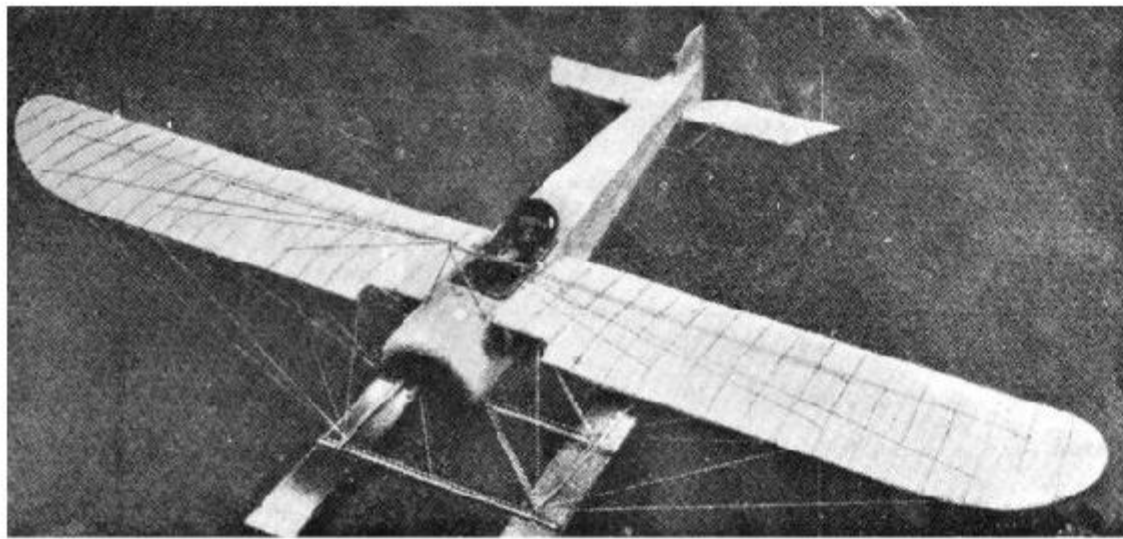

Hydro-avion.

There is also a Denhaut design, 1913, about the same as a *Donnet-Leveque*.

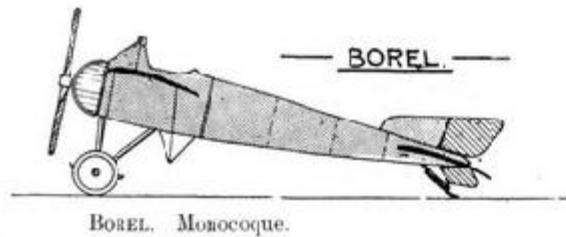

Borel. Monocoque. Uniform Aeroplane Scale

## BREGUET.

Soc. Anonyme des ateliers d'aviation, Louis Breguet, 16 Boulevard Vauban, Donai (Nord). Capacity: about 200 machines a year. Paris office: 25, Boulevard Jules Sandeau. Schools at La Brayelle, pris Douai, Vélisy-Villacoublay, pris Paris.

1913 models.		G2 bis. 2 or 3-seater biplane.	G3. 3-seater biplane.	C-U1. 2-seater biplane.	C-U2. 2-seater biplane.	Aérhydroplane tandem mono. 2-seater, side by side.
Length	feet (m)	33 (10)	29 (8.75)	29 (8.75)	29 (8.75)	29 (8.75)
Span	feet (m)	49 (15)	45 (13.65)	45 (13.65)	45 (13.65)	42 (12.80)
Area	sq. feet (m <sup>2</sup> )	376 (35)	377 (36)	387 (36)	387 (36)	387 (36)
Weight	empty, lbs. (kgs.)	1323 (600)	1212 (550)	1430 (649)	1160 (522)	1760 (798)
	useful lbs. (kgs.)	662 (300)	882 (400)	662 (300)	882 (400)	662 (300)
Motor	h.p.	80 Gnome	100 Gnome	80 Canton Unmé.	110 Canton Unmé.	110 Canton Unmé.
Speed	max. m.p.h. (km.)	62 (100)	69 (110)	62 (100)	71 (115)	87 (140)
	min. m.p.h. (km.)	...	...	...	...	62 (100)
Endurance	hrs.	3-1/2	4	7	7	7
Number built during 1912		A total of 41 sold	during 1912 for	military purposes.		...

*In each case.*—

**Construction.**—All steel.

**Landing chassis.**—C consists of three wheels each protected by skids. The two main wheels, placed on either side of the centre of gravity, are fitted with patent "Oleopneumatic" shock absorbers. The steering wheel and the front skid have a spring suspension.

**Military machines.**—The 1912 sales of these were:—32 to France; 5 British; 3 Italian; 1 Swedish.

**Steering.**—The patented control system consists of a wheel mounted on a pivoted lever. The backward and forward movement of the entire system operates the elevator: the sideways movement warps the rear edge of the upper wings, and the rotation of the wheel steers the

machine. The latter operation also governs the front wheel of the landing chassis, so that when on the ground the machine can be steered like a motor car.

**Portability.**—The main planes can be folded alongside of the fuselage. The machine can then be towed on any ordinary road, or be housed in places such as farm buildings, stables, &c.

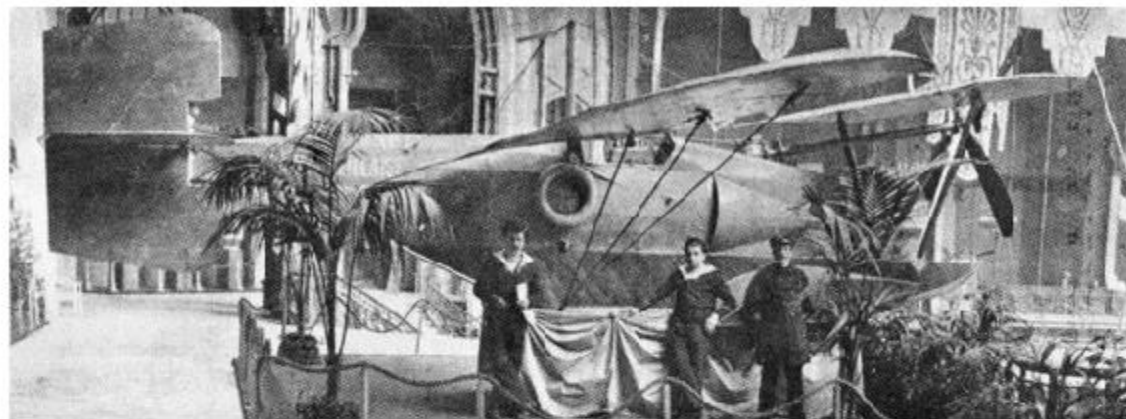

Aerhydroplane, 1913-14.

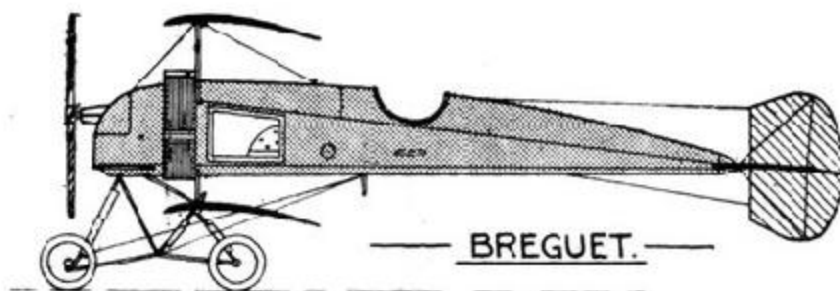

Biplane.

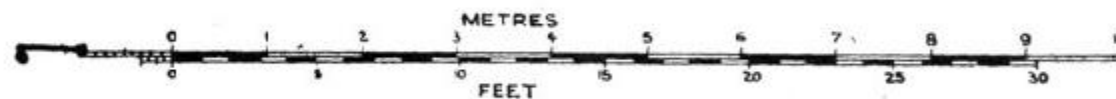

BREGUET. Biplane. Uniform Aeroplane Scale

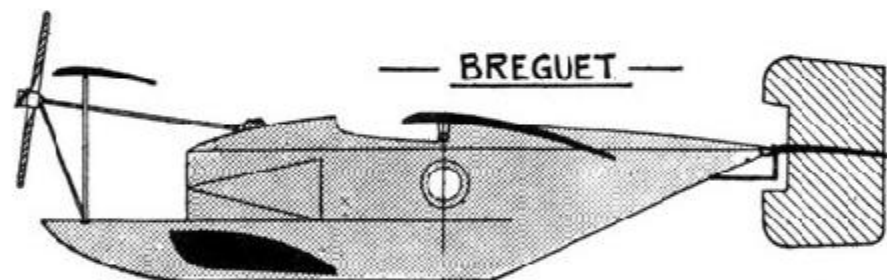

Hydro.

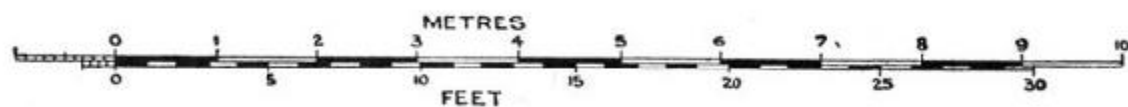

BREGUET. Hydro. Uniform Aeroplane Scale

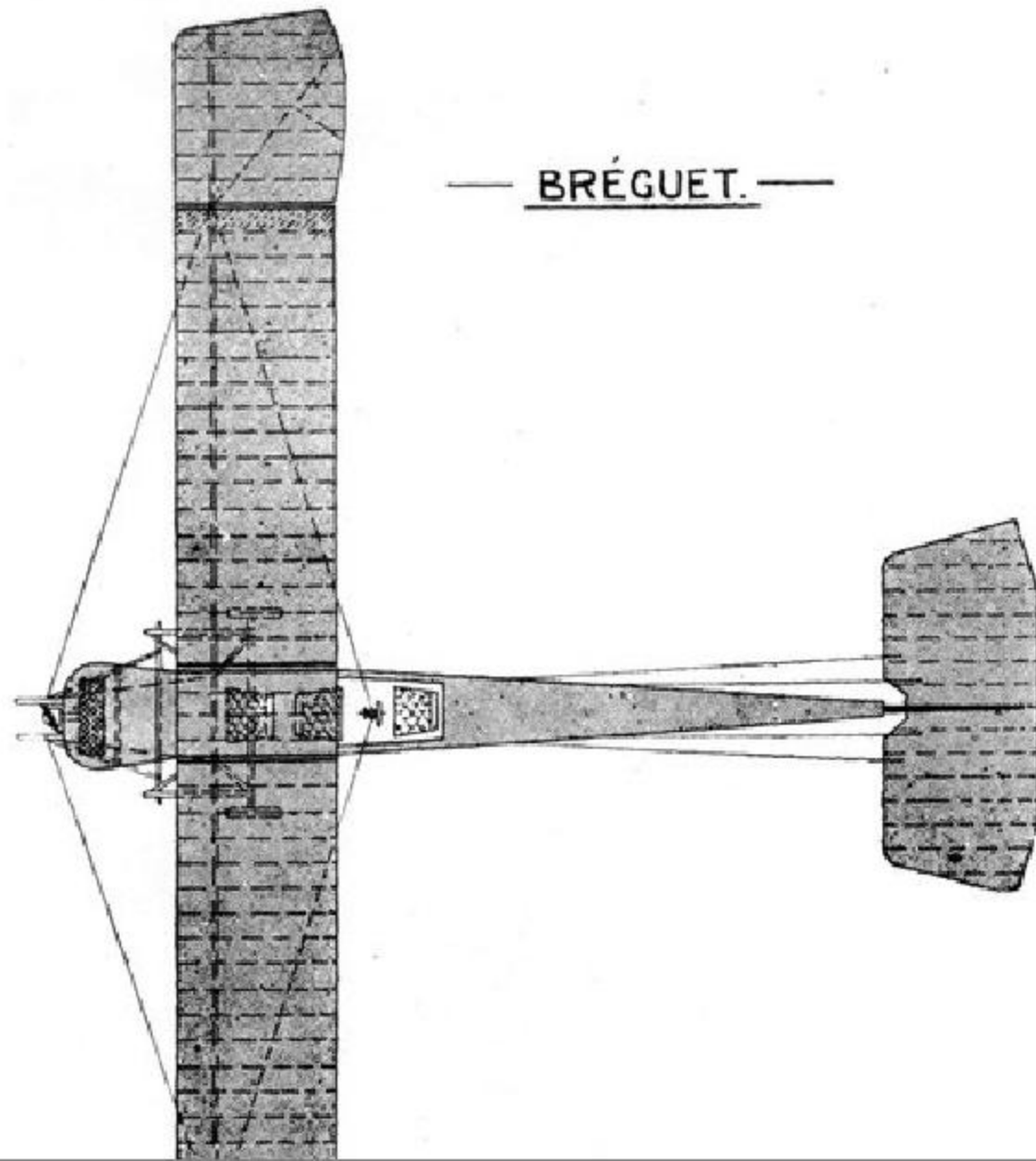
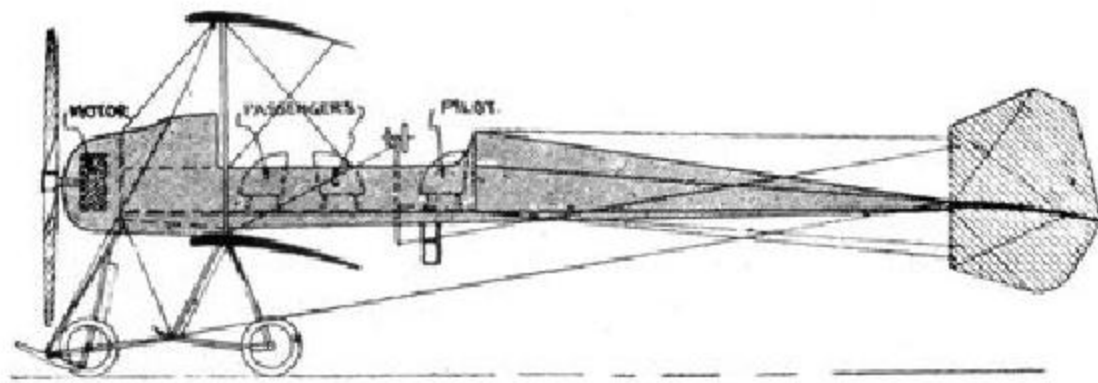

C

## CAUDRON.

Caudron Frères, Rue (Somme). Schools: Crotoy and Juvisy. Capacity: about 100-250 a year.

Model and Date.	M2 1912-13 mono.	N. 1912-13 mono.	G.D. 1912-13 mono.	1913 mono.	B. 1912-13 biplane.	E. 1912-13 biplane.	Monaco type, 1912 hydro- biplane.	1913 hydro- biplane.
Length	feet (m.) 20 (6.10)	19-3/4 (6)	22 (6.75)	19-1/4 (5.80)	26-1/4 (8)	23-1/2 (7.15)	22 (6.75)	32-3/4 (10)
Span	feet (m.) 31 (9.40)	26-1/3 (8)	34 (10.30)	27-1/3 (8.50)	32-3/4 (10)	35-1/2 (10.80)	33 (10.10)	46 (14)
Area	sq. feet (m <sup>2</sup> ) 151 (14)	108 (10)	268 (25)	118 (11)	431 (40)	301 (28)	268 (25)	376 (35)
Weight	machine, lbs. (kgs.) 518 (235)	496 (225)	386 (175)	490 (225)	683 (310)	640 (295)	772 (350)	882 (400)
Motor	h.p. 50 Anzani or Gnome	50 Anzani	Anzani or Gnome	50 Gnome.	Anzani or Gnome	Gnome	Gnome	70 Gnome
Speed	m.p.h. (km.) 71 (115)	84 (135)	75 (120)	84	56 (90)	56 (90)	50 (80)	50 (80)
Number built during 1912	...	...	...	...	...	...	...	...
Notes.--Lateral control, warping. Wood construction. On wheels. Enclosed body.							Lateral control, warping. Wood construction. On wheels as well as floats. (Special Caudron patent.)	

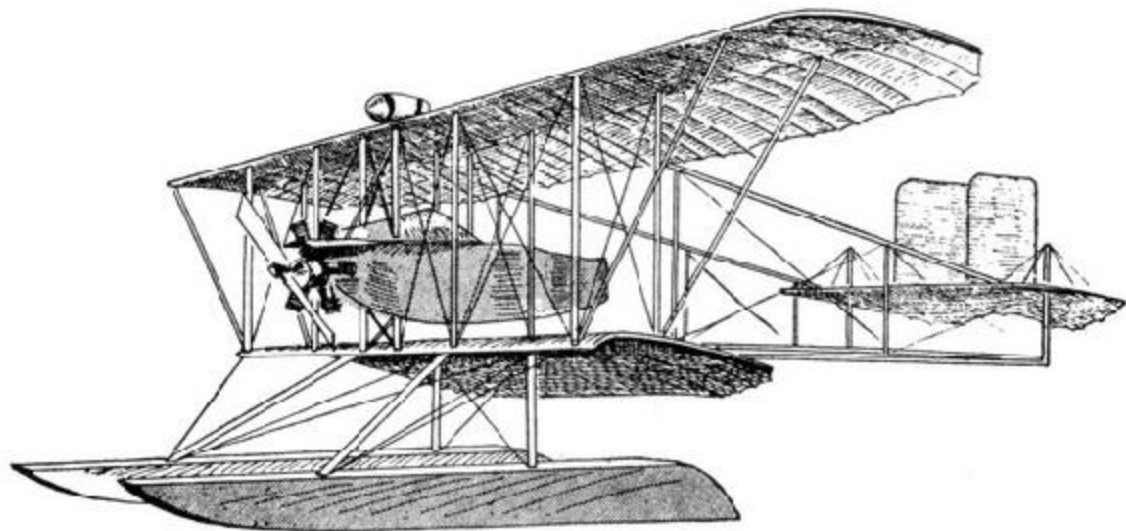

1912 hydro. By favour of "Aeronautics," U.S.A. Uniform Aeroplane Scale

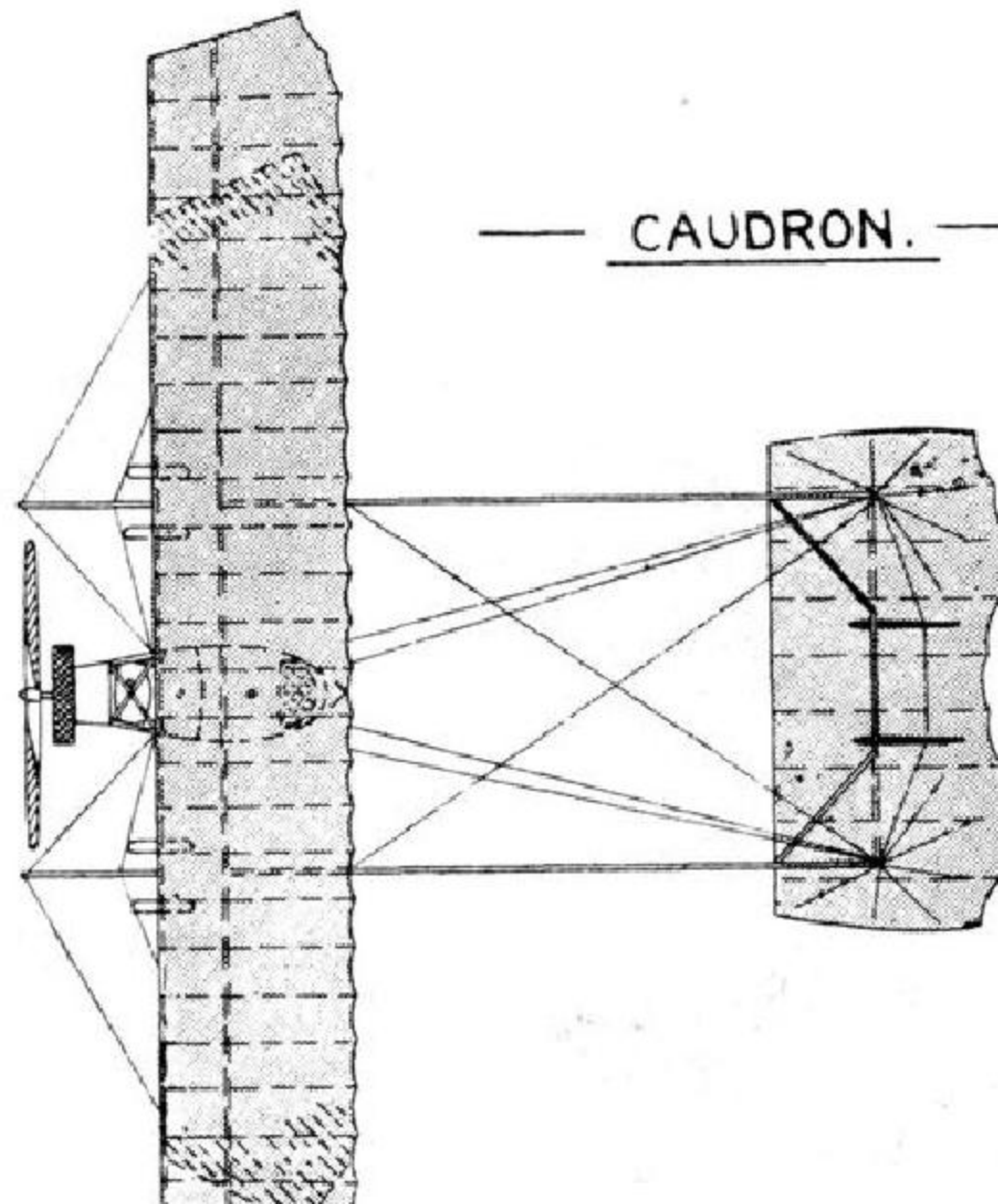
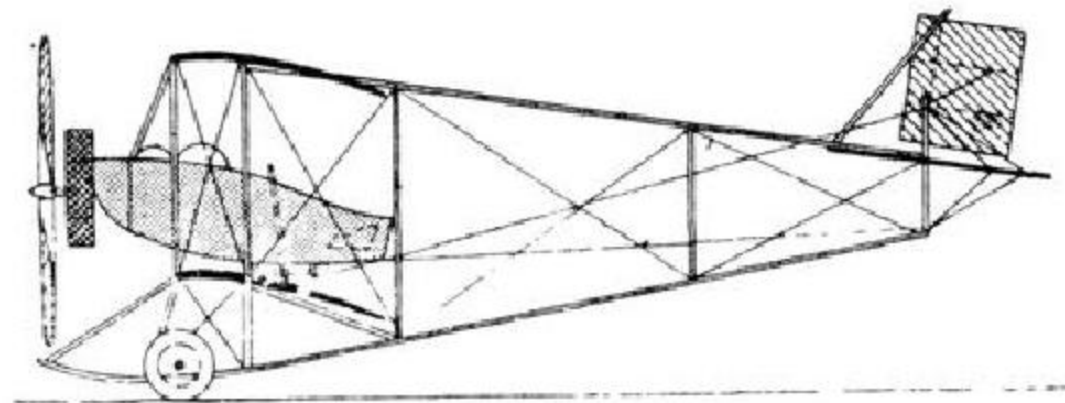

— CAUDRON. —



CAUDRON. Uniform Aeroplane Scale

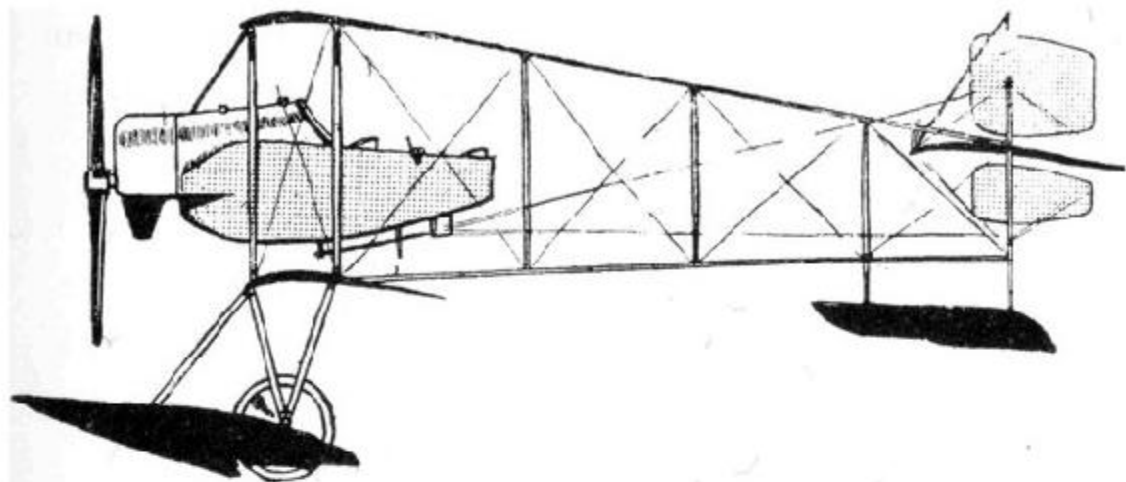

1913 hydro. Uniform Aeroplane Scale

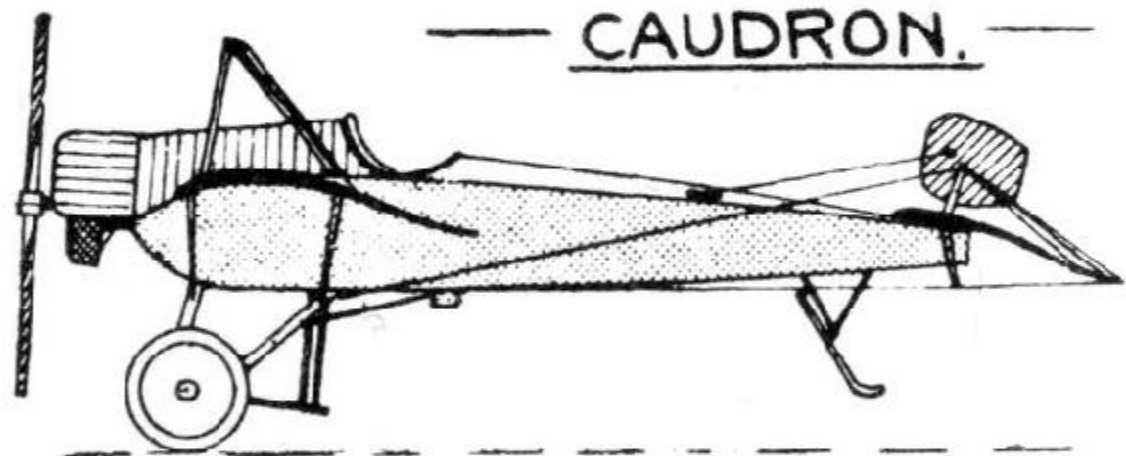

CAUDRON. Mono. *By favour of "Flight."* Uniform Aeroplane Scale

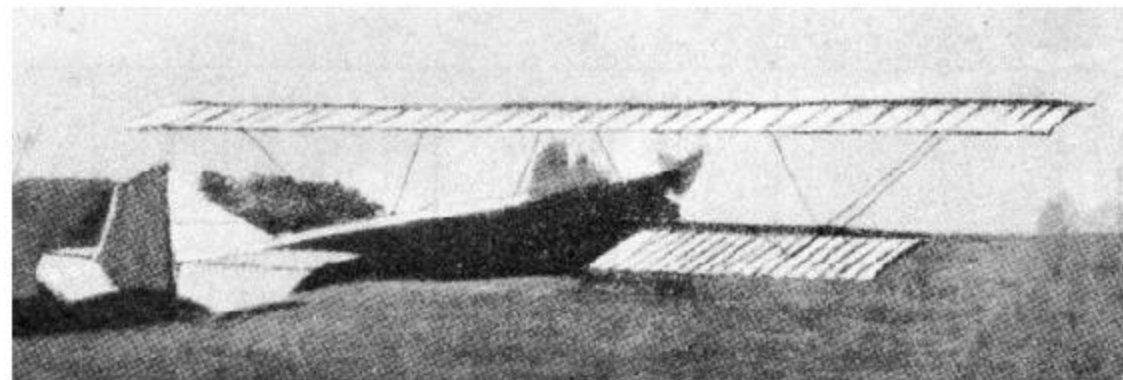

		1913. Military 3-seater biplane.	1913. Military single seater monoplane.
Length	feet (m)	37 (11.20)	24-2/3 (7.50)
Span	upper feet (m)	52 (16)	30 (9.20)
	lower feet (m)	36 (11)	...
Area	sq. feet (m <sup>2</sup> .)	533 (50)	172 (16)
Weight	total lbs. (kgs.)	2425 (1100)	1146 (520)
	useful lbs. (kgs.)	1014 (460)	441 (200)
Motor	h.p.	100 Gnome	70 Gnome
Speed	max. m.p.h. (km.)	53 (85)	75 (120)
	min. m.p.h. (km.)	...	...
Endurance	hrs.	...	...

Notes.—Control: lateral, warping.

**D**

**CLEMENT-BAYARD.**

Usines Clement-Bayard, 33 quai Michelet, Levallois-Perret (Seine).

**D'ARTOIS.**

Soc. Anonyme des Anciens Chantiers Tellier, Longuenesse, pres St. Omer. Re-established 1912. Capacity: small.

Model and date.		1913 model. "Aero torpille" hydro-biplane.	1913 "Aero torpille" biplane.
Length	feet (m.)	23 (7)	24-3/4 (7.50)
Span	feet (m.)	36 (11)	36 (11)
		20 (6)	20 (6)
Area	sq. feet (m <sup>2</sup> .)	280 (26)	280 (26)
Weight	empty, lbs. (kgs.)	772 (350)	551 (250)
Motor	h.p.	50 Gnome	50 Gnome
Speed	m.p.h. (km.)	56 (90)	84 (135)
Endurance	hrs.	...	...
Number built during 1912		...	...

Notes.—Single long boat body, canoe-shape.

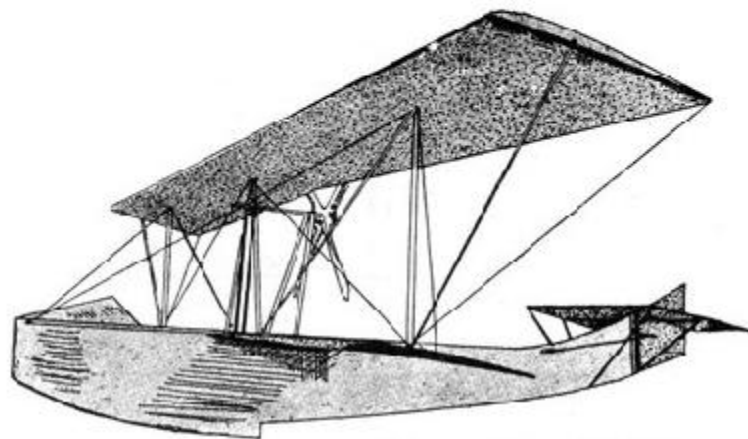

By favour of "Aeronautics," U.S.A.



By favour of "Aeronautics," U.S.A. Uniform Aeroplane Scale

**DEPERDUSSIN.** Armand Deperdussin, 19 rue des Entrepreneurs, Paris. School: Courey-Betheny (Marne). Established 1910. Capacity: about 150-200 machines a year.

		E 1912-13. school mono.	P 1912-13. single seater mono.	T 1912-13. 2-seater mono.	H 1912-13. 3-seater mono.	Monocoque 1913. 2- seater.	Mono. 1913. 2- seater.
Length	feet (m)	24 (7.30)	24 (7.30)	24 (7.30)	29 (8.80)	19 (5.75)	...
Span	feet (m)	29 (8.85)	28 (8.50)	35 (10.65)	41 (12.50)	29-1/2 (8.95)	36 (11)
Area	sq. feet (m <sup>2</sup> .)	...	162 (15)	...	310 (28)	97 (9)	...
Weight	total lbs. (kgs.)	661 (300)	782 (355)	1212 (550)	2050 (930)	882 (400)	...
	useful lbs. (kgs.)	...	...	...	...	...	...
Motor	h.p.	30 Anzani	50 Gnome	70 Gnome	100 Gnome	50 Gnome	80 Gnome
Speed	max. m.p.h. (km.)	50 (80)	69 (110)	65 (105)	69 (110)	113 (180)	105 (170)
	min. m.p.h. (km.)	...	...	...	...	81 (130)	...
Endurance	hrs.	...	...	...	...	...	...
Number built during 1912		2	5	27	3	2	1

Notes.—Wood construction. Lateral control by warping. Mounted on wheels without skids. Fabric: "Aviator" Ramie.

Principal *Deperdussin* records: 1912 Gordon Bennett (Vedrine) and a number of world records for speed and distance.

Principal pilots include: Busson, Prévost, Vedrine, Vidart.

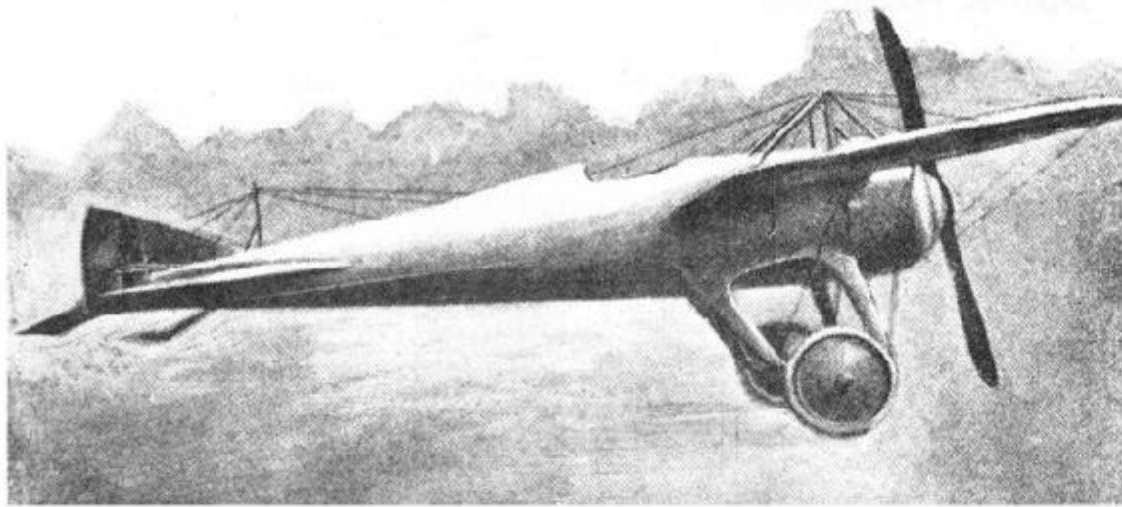

50 h.p. monocoque.

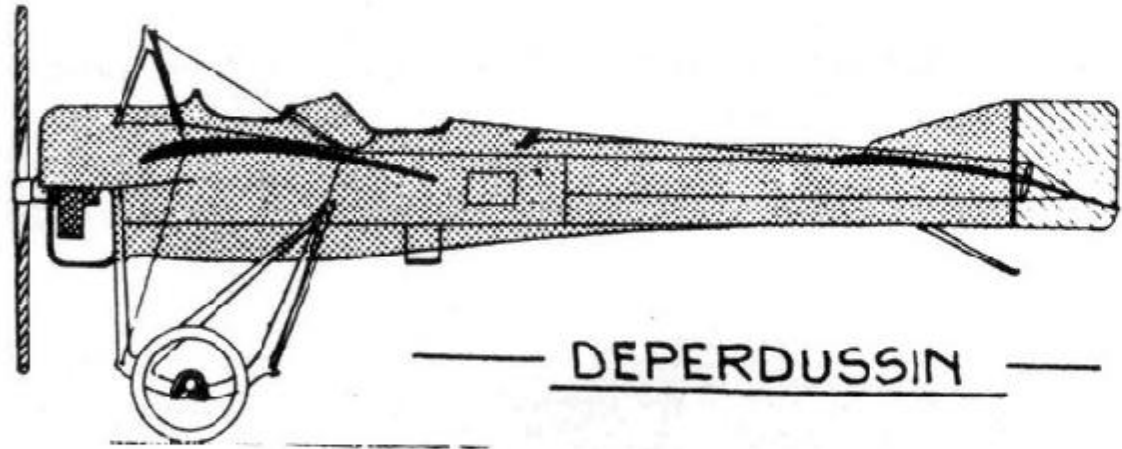

DEPERDUSSIN. 80 h.p. Uniform Aeroplane Scale



The 80 h.p. mounted on floats as a hydro.

### DONNET-LEVEQUE.

		A 1912. 2-seater hydro-biplane	B 1912. 2-seater hydro-biplane	C 1912. 3-seater hydro-biplane	1913. 2-seater hydro-biplane
Length	feet (m)	26 (7.80)	27 (8.30)	27 (8.30)	34-1/2 (10.50)
Span	feet (m)	29-1/2 (9)	32-3/4 (10)	34-1/2 (10.50)	29-1/2 (9)
Area	sq. feet (m <sup>2</sup> .)	194 (18)	215 (20)	237 (22)	194 (18)
Weight	lbs. (kgs.)	683 (310)	772 (350)	888 (380)	888 (380)
Motor	h.p.	50 Gnome	70 Gnome	80 Gnome	50 Gnome
Speed	m.p.h. (km.)	69 (110)	75 (120)	...	50 (80)
Endurance	hrs.	...	...	...	...
Number built during 1912		...	...	...	...

*Notes.*—Lateral control by warping ailerons. Motor in gap just below upper plane: propeller in rear, direct driven. Fabric: "Aviator" Ramie.

*Floats.*—One large central boat 27 feet (8.20 m.) long—two small ones at each extremity of lower plane.

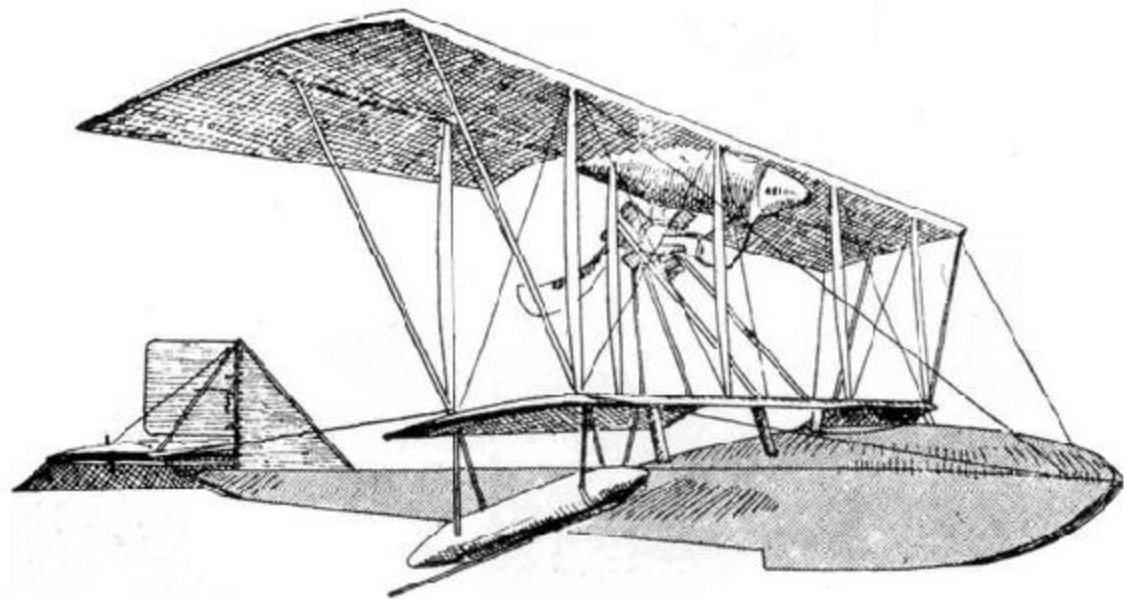

By favour of "Aeronautics," U.S.A.

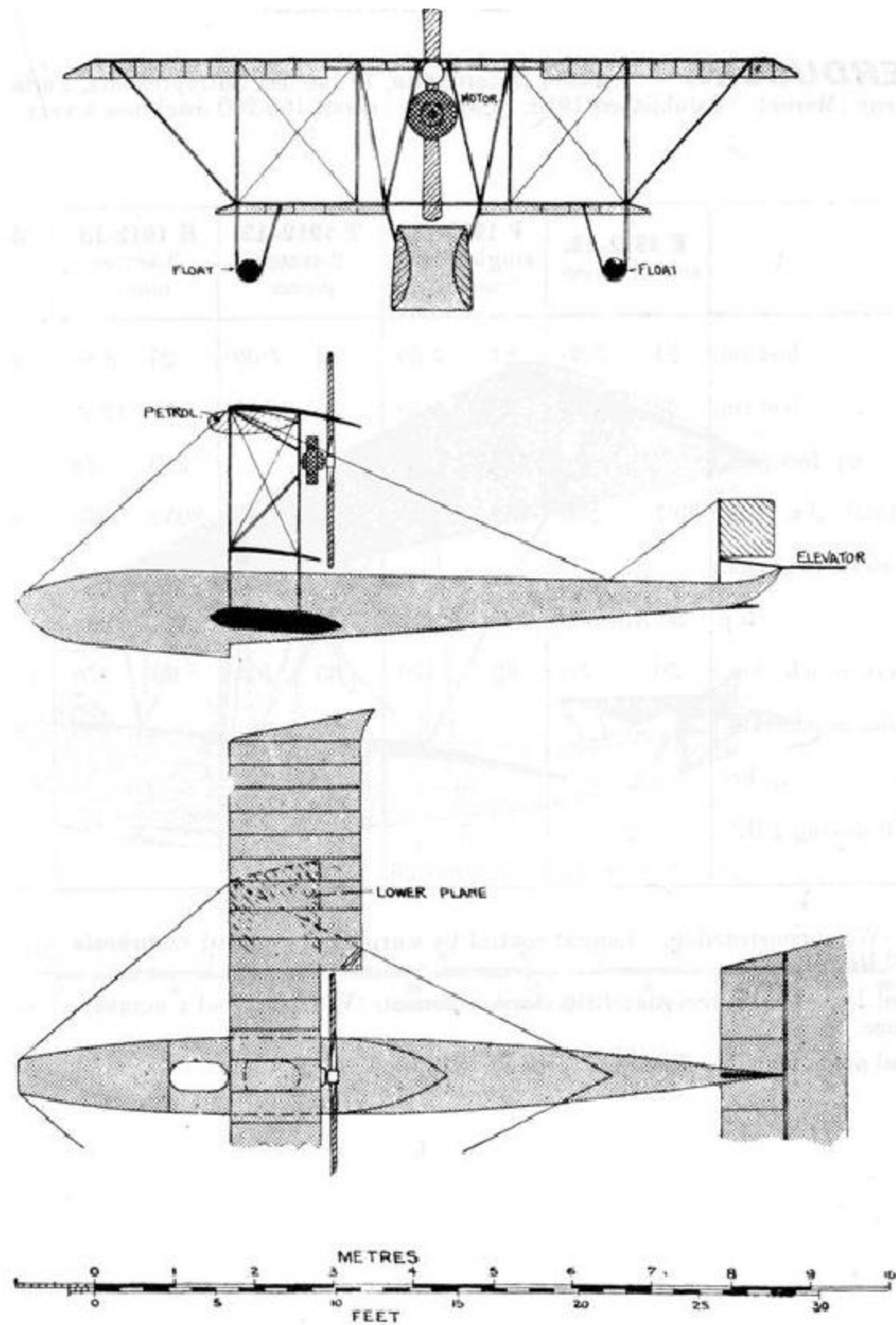

**DOUTRE.**

Soc. Anonyme Dautre, 58, rue Talbot, Paris.

Type.		Biplane 3-seater, 1912-13.	Biplane 2-seater, 1912-13.
Length	feet (m.)	40 (12.25)	...
Span	feet (m.)	53 (16.10)	...
		43 (13)	...
Area	sq. feet (m <sup>2</sup> .)	533 (50)	...
Weight	machine lbs. (kgs.)	1323 (600)	1323 (600)
	useful lbs. (kgs.)	992 (450)	992 (450)
Motor	h.p.	70 Renault	50 Renault
Speed	max. m.p.h (km.)	56 (90)	56 (90)
Number built during 1912		1	?

*Notes.*—Fabric: "Aviator" Ramie. Both types fitted with the Dautre patent stabiliser, which automatically and instantaneously counteracts troubles due to sudden gusts or partial motor failures. Weight of the 1913 model stabiliser is only 44 lbs. (20 kgs.)

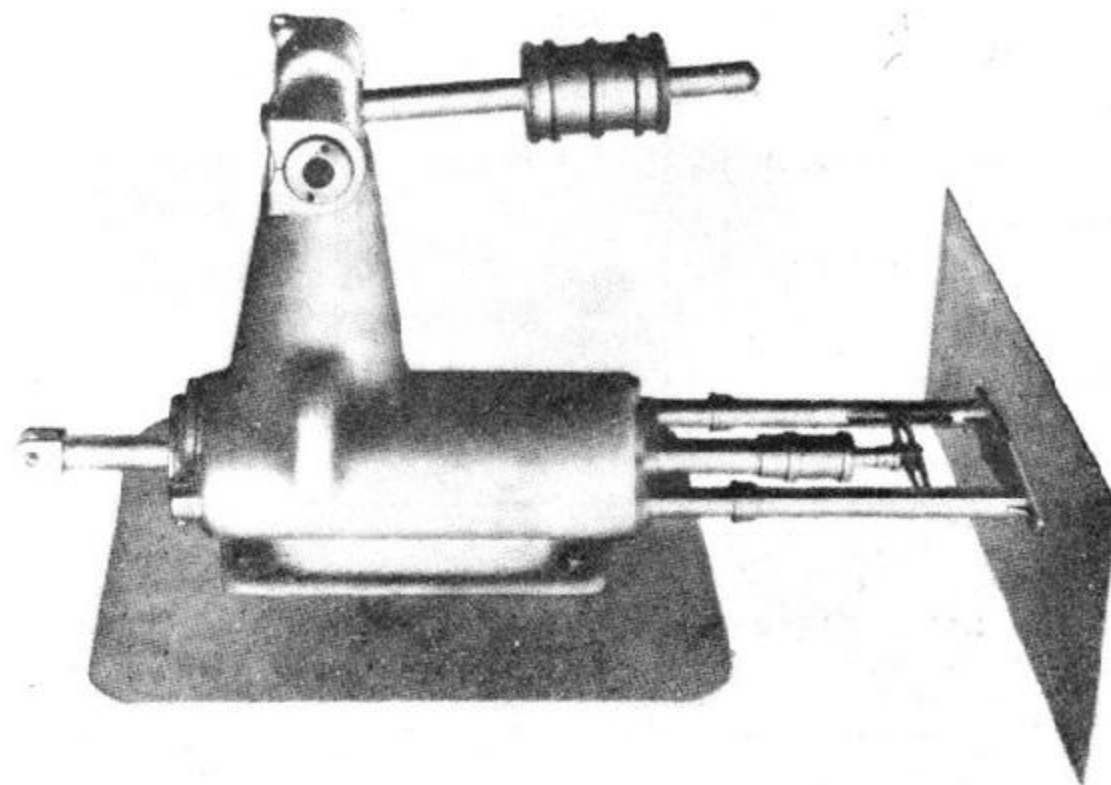

Model 1913 stabiliser.

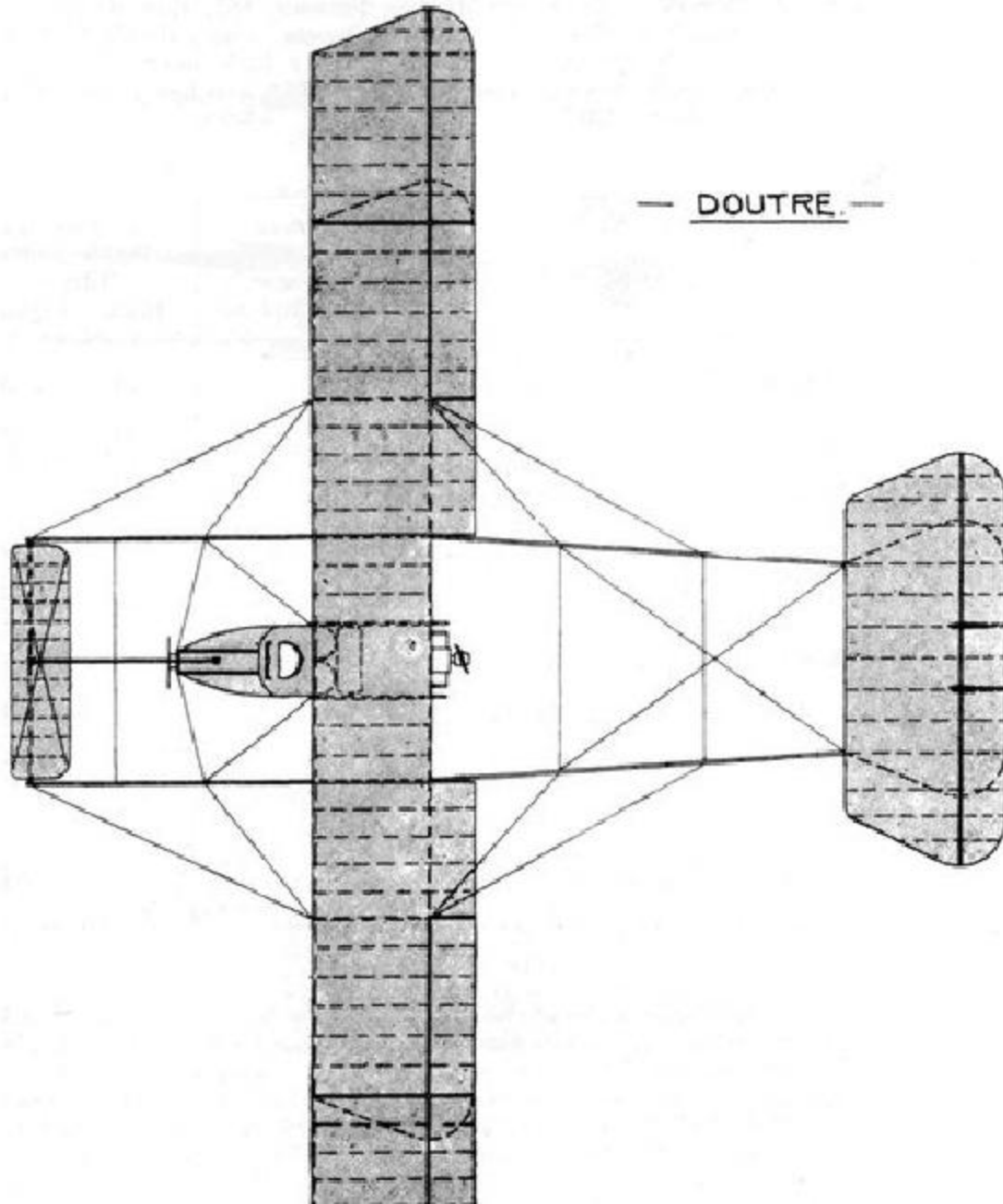
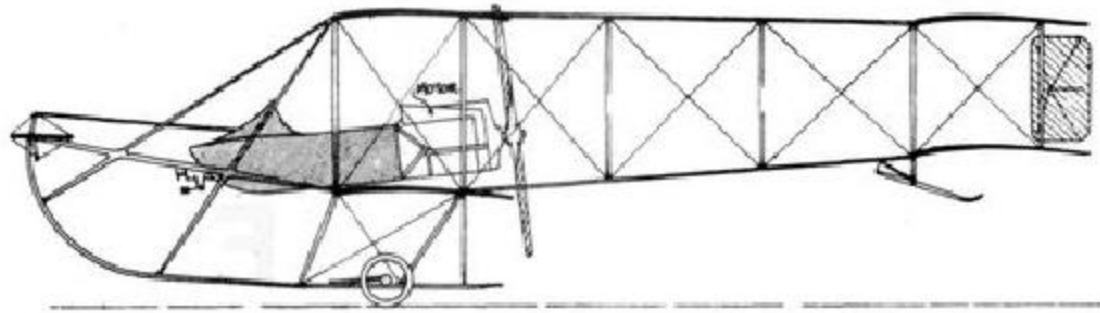

## FARMAN.

Henry and Maurice Farman, 167, Rue de Silly, Billancourt (Seine) Aerodromes: Buc, pres Versailles and Etampes. Depots: Camp de Chalons—Reims. Established by H. Farman in 1908. M. Farman established works a little later. In 1912 the two brothers combined. The present works were opened in January, 1912, and had an output capacity of at least 300 machines a year in March, 1913.

		<i>H.</i> <i>Farman.</i> Military. 2 or 3- seater. 1912-13. Biplane.	<i>H.</i> <i>Farman.</i> Single- seater. Military. 1913. Biplane.	<i>H. Farman.</i> 2-seater monoplane.	<i>H.</i> <i>Farman.</i> 2-seater special hydro- biplane. 1913.	<i>M.</i> <i>Farman.</i> Military biplane.	<i>M.</i> <i>Farman.</i> Big military biplane.	<i>M.</i> <i>Farman.</i> Staggered biplane.
Length	feet (m.)	26-1/4 (8)	24 (7.35)	24-1/2 (7.50)	26 (7.90)	39-1/3 (12)	46 (14)	39 (11.90)
Span	feet (m.)	42-3/4 (13.25)	31-1/8 (9.50)	32-3/4 (10)	45 (13.70)	50-3/4 (15.50)	65-3/4 (20)	36 (11)
Area	sq. feet (m <sup>2</sup> .)	376 (35)	161 (15)	204 (19)	344 (32)	646 (60)	861 (80)	323 (30)
Weight	total lbs. (kgs.)	793 (360)	640 (295)	628 (285)	950 (431)	1102 (500)	1433 (650)	882 (400)
	useful lbs. (kgs.)	661 (300)	386 (175)	...	...	617 (280)	882 (400)	551 (250)
Motor	h.p.	70-80 Gnome	70-80 Gnome	Designed for Gnomes from 40 up to 160 h.p.	50 Gnome	70 Renault	70 Renault	70 Renault
Speed	max. m.p.h. (km)	65 (105)	71 (15)	...	52 (100)	56 (90)	44 (70)	69 (110)

	min.	...	...	...	...	...	...	...
	m.p.h.	...	...	...	...	...	...	...
	(km)	...	...	...	...	...	...	...
Endurance	hrs.	3	...	...	...	...	...	...
Number built during 1912		...	...	...	...	...	...	...

*Remarks.*—The whole of the above can easily be converted into hydro-avions—two long narrow floats without steps. *H. Farmans* are of wood and steel construction; *M. Farman*, wood. In all 1913 biplanes the ailerons are inter-connected. All 1913 machines designed to carry one or in some cases two mitrailleuse, and special attention is paid to facility for taking down for transport and re-assembling. The 1911-12 *H. Farmans* had elevators forward, were a good deal longer, and had more surface than 1913 models. Ailerons not inter-connected. The *M. Farmans* generally as now, except that all planes, etc., had rounded edges. On September 11th, 1912, Foury, in an *M. Farman* military, made world's endurance record to date, 13 hrs. 22 min., covering 631 miles (1,017 km.) All models of this type, also the "big military," are fitted with the Doutré stabiliser. Fabric: "Aviator" Ramie.

**Latest Hydro.**—In March, 1913, a new hydro was produced experimentally. There is a boat body, without steps, carrying the motor which is chain connected with the propeller. Machine is fitted with wheels and skids as well.

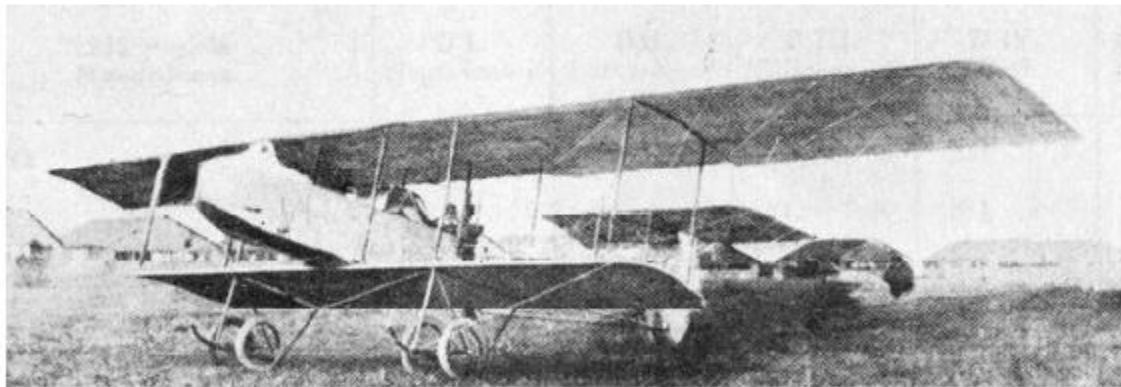

H. Farman. 1912-13 military biplane.

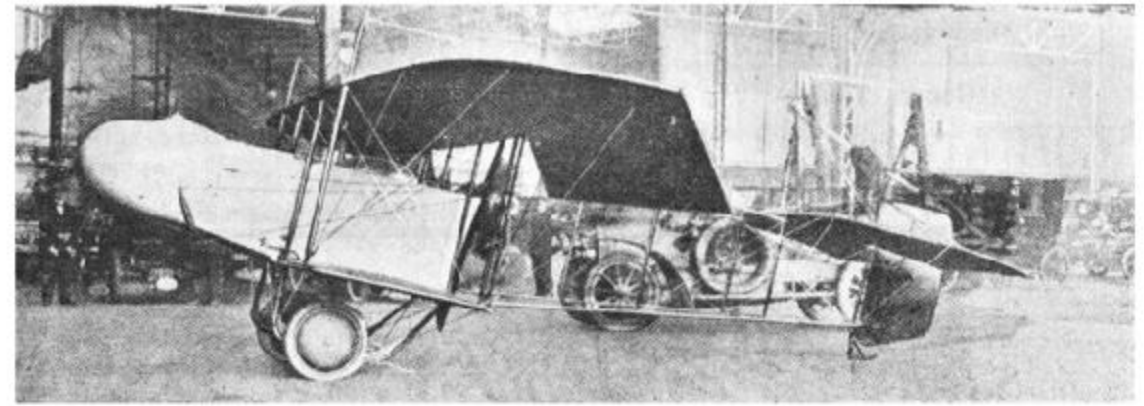

H. Farman. 1913 latest type military biplane.

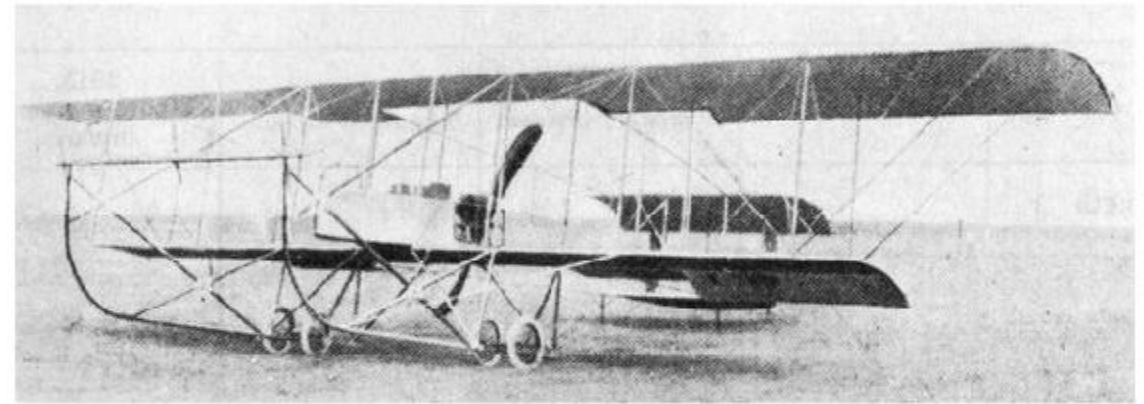

M. Farman. 1912-13 military biplane.



M. Farman. 1912-13 staggered biplane. This is the type which has done best as a hydro-aeroplane.

## G

### GOUPY.

A. Goupy, 50, Avenue Marceau, Paris. School: Juvisy (Port Aviation). Capacity: about 30 machines a year.

Model and date.		1913 A. Staggered biplane.	1913 B. Staggered biplane.	1913. Hydro-staggered biplane.
Length	feet (m.)	25 (7.50)	26-1/4 (8)	33 (10)
Span	feet (m.)	26-1/4 (8)	42-3/4 (13)	42 (12.70)
Area	sq. feet (m <sup>2</sup> )	...	...	480 (45)
Weight	machine lbs. (kgs.)	...	...	992 (450)
	useful lbs. (kgs.)	...	...	661 (300)
Motor	h.p.	50 Gnome	80 or 100 Gnome	80 Gnome
Speed	max. m.p.h. (km.)	62 (100)	75 (120)	75 (120)
	min. m.p.h. (km.)	...	...	...
Endurance	hrs.	...	...	...
Number built during 1912		...	12	1

Fabric: "Aviator" Ramie.

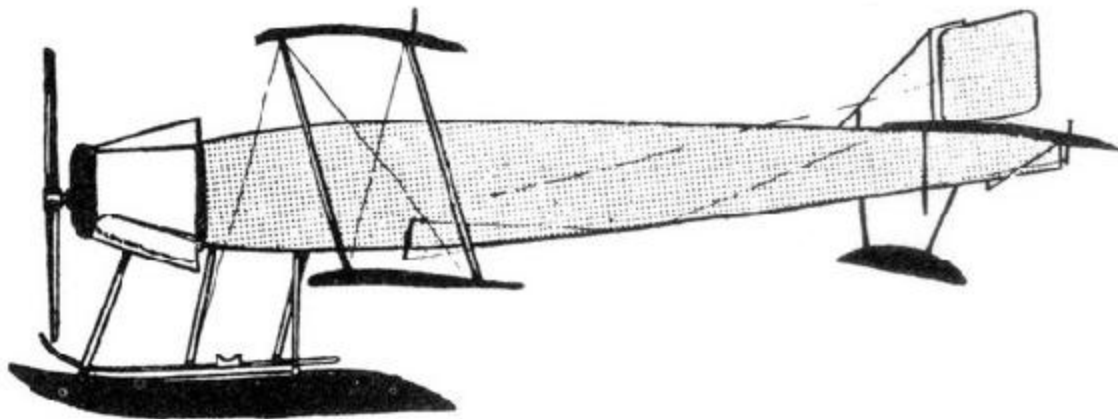

Goupy. Hydro. From "Flight." Uniform Aeroplane Scale

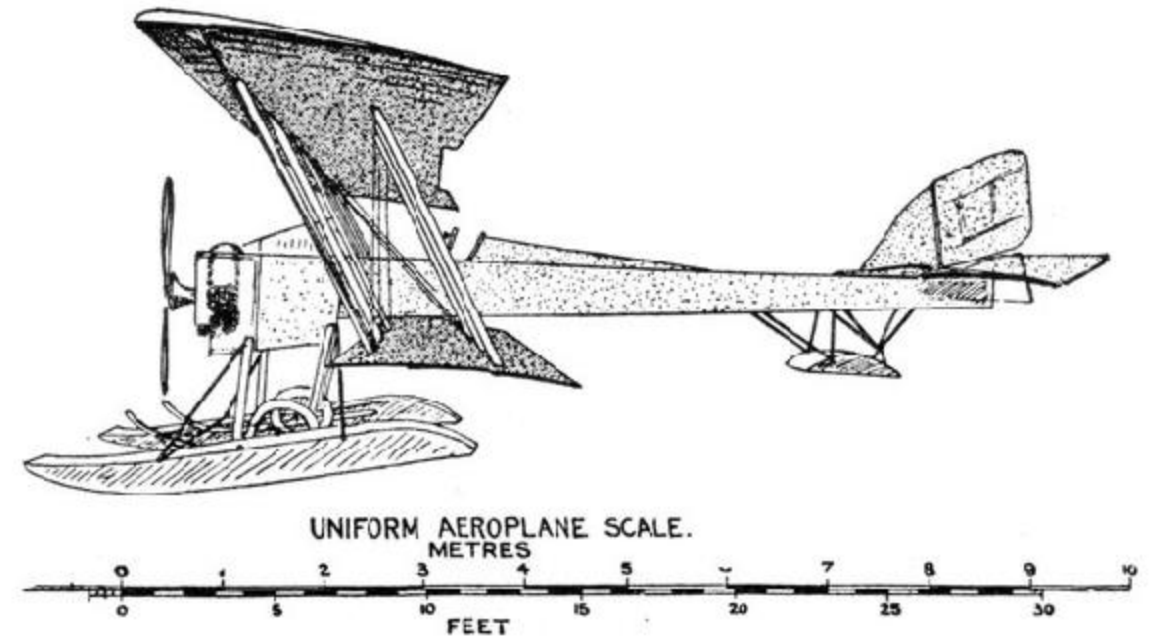

Goupy. Hydro. By favour of "Aeronautics," U.S.A. Uniform Aeroplane Scale

## H

### HANRIOT.

Aeroplanes Hanriot & Cie., 145 rue de Neufchatel, Reims. Paris office: 69 boulevard Berthier, Paris. School: Antibes, Reims.



1913 models. Monoplanes.		D I. Single seater.	D II. 2 or 3- seater.	D III. Racer.	D IV. Steel.	D VII.
Length	feet (m.)	23 (7)	26-1/3 (8)	21-3/4 (6.65)	23 (7)	23 (7)
Span	feet (m.)	28-1/3 (8.70)	42-3/4 (13)	24 (7.30)	28-1/3 (8.65)	36 (10.95)
Area	sq. feet (m <sup>2</sup> )	161 (15)	226 (21)	91 (8.50)	161 (15)	194 (18)
Weight	machine lbs. (kgs.)	661 (300)	937 (425)	661 (300)	661 (300)	771 (350)
	useful lbs. (kgs.)	...	616 (280)	...	396 (180)	364 (165)
Motor	h.p.	50 Anzani	100 Gnome	100 Gnome	50 R. Peugeot	80 Gnome
Speed	max. m.p.h. (km.)	69 (110)	78 (125)	106 (170)	71 (115)	71 (115)
	min. m.p.h. (km.)	...	...	...	...	...
Endurance	hrs.	...	...	...	...	...
Number built during 1912		...	...	...	...	...

Notes.—There are also two school types 35 and 45 h.p. Records include 1912 world record for speed with passengers.

None of the above machines represent any very particular divergence from recognised *Hanriot* practice. *D IV* is all steel construction, the others wood and steel.

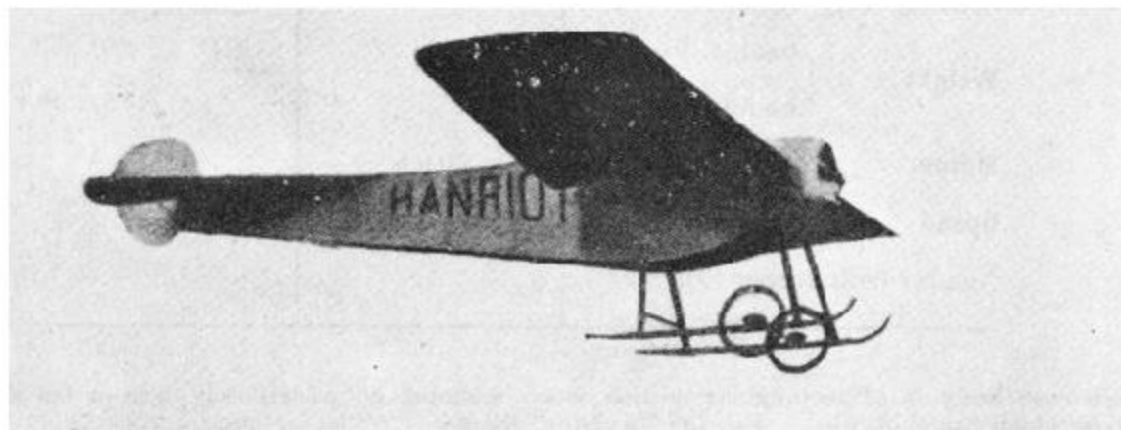

Hanriot

M

### MORANE-SAULNIER.

Soc. de constructions aéronautiques, Morane-Saulnier. 206 Boulevard Pereire. Capital: 1,500,000 francs. School: Villacoublay. Output capacity: about 50 machines a year.

		Military, 1913.	2 places. Tandem.
Length	feet (m.)	21 (6.38)	21 (6.38)
Span	feet (m.)	30-1/5 (9.20)	33-1/2 (10.20)
Surface	sq. feet (m <sup>2</sup> .)	151 (14)	172 (16)
Weight	total lbs. (kgs.)	595 (270)	617 (280)
	useful lbs. (kgs.)	...	...
Motor	h.p.	50 h.p.	80 h.p.
Speed	m.p.h. (km.)	75 (120)	75 (120)
Number built during 1912		...	...

In each case **body** is of rectangular section, wood, mounted on wheels only, except for the **military** type which has skids also. Fabric: "Aviator" Ramie.

In all there is a rear elevator and a Chauvière tractor.

Note.—Flown in the European Circuit, 1911, by Vedrines, Gajet, Lesire, Morisson, Verept, Frey, Garnier and Dalgier.

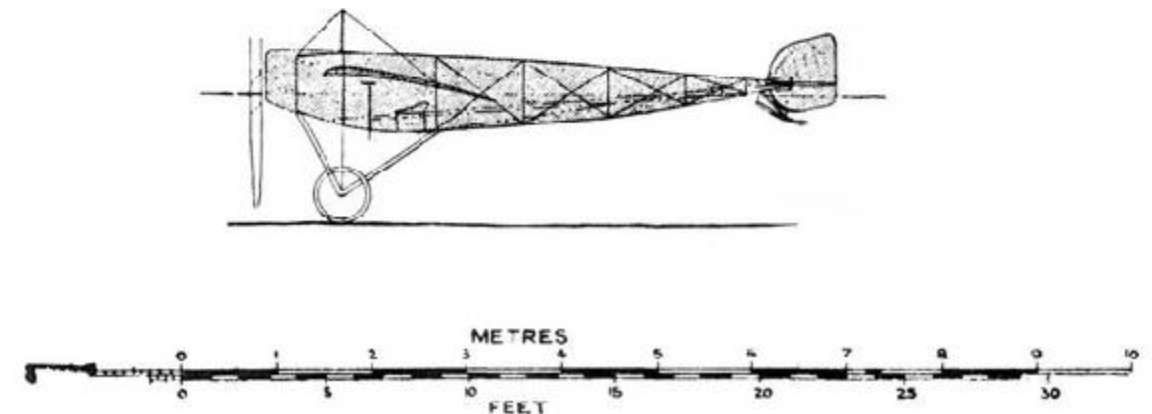



Motor	h.p.	30 Nieuport	Gnome	Gnome	Gnome	Gnome	50 Gnome	30 Nieuport	100 Gnome
Speed	max. m.p.h. (km.)	75 (120)	87 (140)	72 (117)	72 (117)	69 (110)	78 (125)	69 (110)	72 (117)
	min. m.p.h. (km.)	...	75 (120)	69 (110)	...	...	...	...	...
Number built during 1912		...	...	...	...	...	...	...	...

Notes.—Early types had a *Hanriot* style landing carriage; the 1913 models revert to a *Bleriot* type. Warping wings. Fuselage entirely enclosed, rectilinear with rounded nose.

Model and date. <b>Biplanes.</b>		Flying boat. Single-seater.	Flying boat. 2-seater.
Length	feet (m.)	...	27 (8.30)
Span	feet (m.)	35-1/2 (10.80)	37 (11.30)
Area	sq. feet (m <sup>2</sup> .)	...	290 (26-3/4)
Weight	machine lbs. (kgs.)	...	948 (430)
	useful lbs. (kgs.)	...	...
Motor	h.p.	75 Curtiss	85 Curtiss
Speed	m.p.h. (km.)	...	...
Number built during 1912		2	8

### PISCHOFF.

Établissements Autoplan, 4 rue Beranger, Boulogne sur Seine (Seine).

This firm has produced various types in the past, but at present, appears confined to constructing to specifications (See *Pischoff-Werner* last edition).

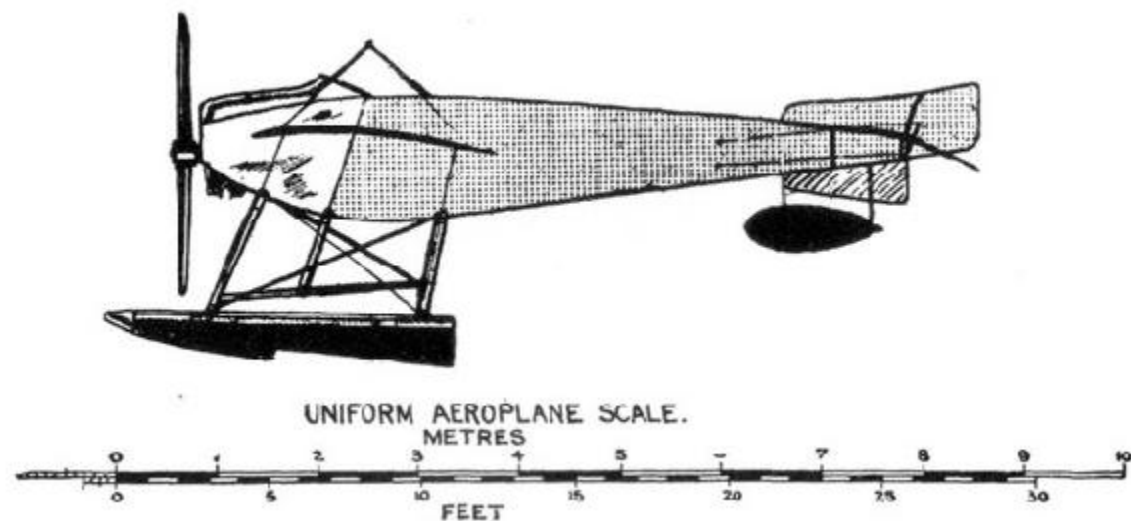

Nieuport. Hydro. By favour of "Flight." Uniform Aeroplane Scale

P

### PAULHAN-CURTISS.

Soc. anonyme d'aviation Paulhan, (S.A.P.) 71 boulevard Berthier, Paris. Flying ground: Bois d'Arcy par St. Ayr (S. et O.) Hydro school: Juan-les-Pins, par Antibes (Alpes Maritimes).

Founded by the well-known aviator, L. Paulhan. He first produced biplanes, then triplanes and finally a monoplane type, the *Tatin-Paulhan* (1911). These are now all abandoned, and the firm devotes itself to building hydro-aeroplanes under Curtiss (U.S.A.) license. Principal type built are:—

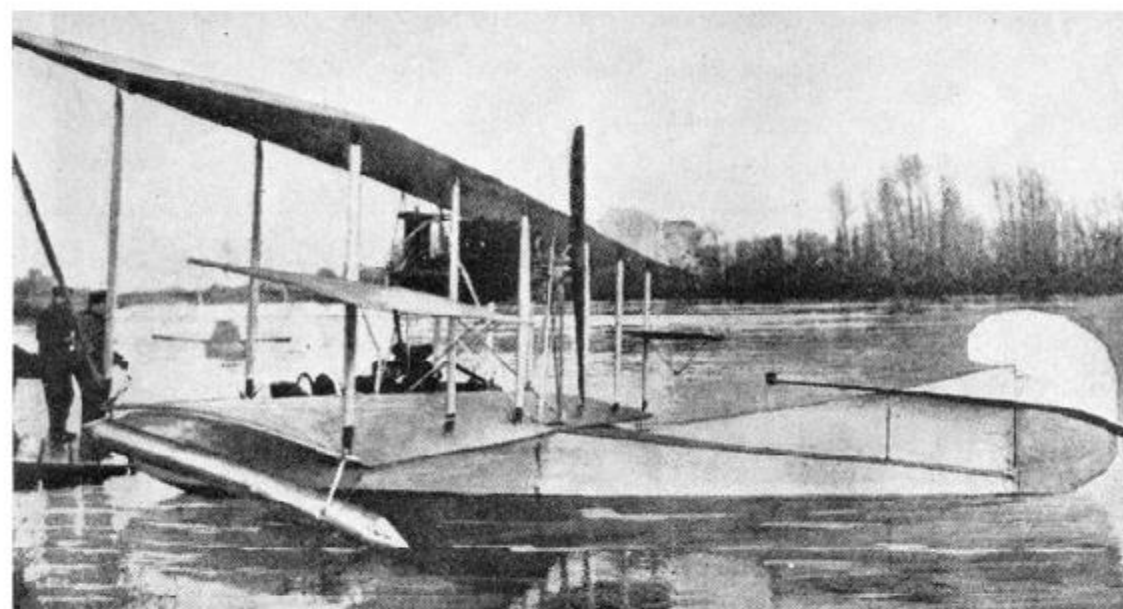

Paulhan-Curtiss. Flying boat.

R

R.E.P.

Robert Esnault-Pelterie, Billancourt. School: Bue. One of the earliest established French firms. The first to go in for steel construction. Reported to have amalgamated with *Breguet* in 1912, but this fell through.

Model. Steel monoplanes.		1912. 1-seater.	1912. 2-seater.	1912. Military. 3-seater.	1913. 2-seater.	1913. Hydro-mono. 2-seater.
Length	feet (m.)	25-1/3 (7.70)	25-1/3 (7.70)	25-1/3 (7.70)	23 (7)	25 (7.50)
Span	feet (m.)	35 (10.70)	38-1/3 (11.70)	38-1/3 (11.70)	36 (11)	38-1/4 (11.60)
Area	sq. feet (m <sup>2</sup> .)	215 (20)	237 (22)	323 (30)	237 (22)	323 (20)
Weight	machine lbs. (kgs.)	882 (400)	661 (300)	882 (400)	595 (270)	...
	useful lbs. (kgs.)	...	...	...	...	...
Motor	make and h.p.	60 Rep.	66 Rep.	90 Rep.	95 Rep.	80 Rep.
Speed	max. mph. (km.)	69 (110)	69 (110)	69 (110)	78 (125)	78 (125)
	min. mph. (km.)	...	...	...	62 (100)	62 (100)
Number built during 1912		...	...	...	...	...

Remarks:—Steel construction. Pentagonal and triangular body. Mounted on wheels and skids. The hydro is on one very large central float.

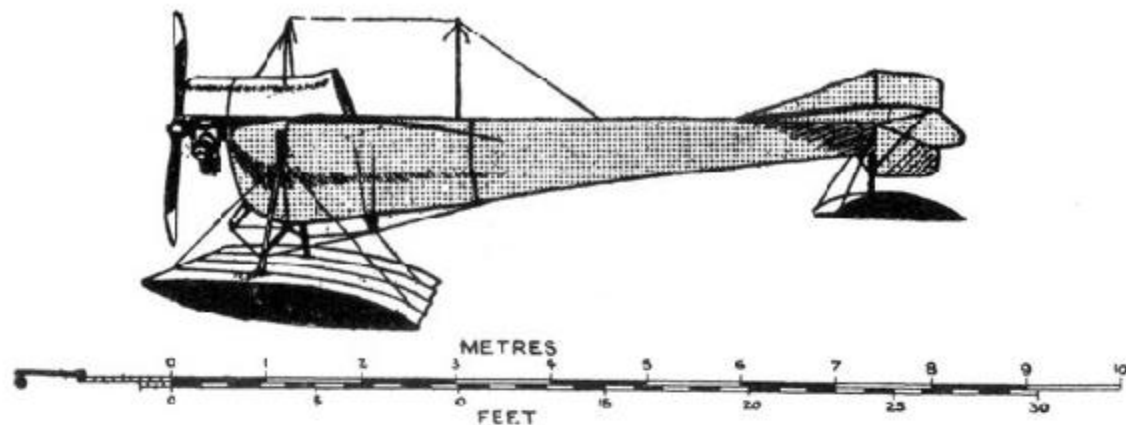

Flight. Uniform Aeroplane Scale

S

### SANCHEZ BESA.

2 avenue de Villiers, Paris.

Model and date.		1912. Hydro-biplane.	1912. Hydro-biplane.	1913. Hydro-biplane. (amphibious)
Length	feet (m.)	34 (10.40)	...	32-3/4 (10)
Span	feet (m.)	54 (16.40)	55-3/4 (17)	54-3/4 (16.60)
Area	sq. feet (m <sup>2</sup> .)	646 (60)	...	646 (60)
Weight	à vide lbs. (kgs.)	1984 (900)	...	1102 (500)
	useful lbs. (kgs.)	...	...	...
Motor	h.p.	100 Renault	70 Renault	70 Renault
Speed	max. m.p.h. (km.)	56 (90)	...	50 (80)
Endurance	hrs.	5	5	6
Number built during 1912		3	1	1

Notes.—Wood and steel construction.

Controls.—Ailerons and rear elevators. Floats: The first has two and the second three floats. The 1913 model has a single boat body mounted on wheels.

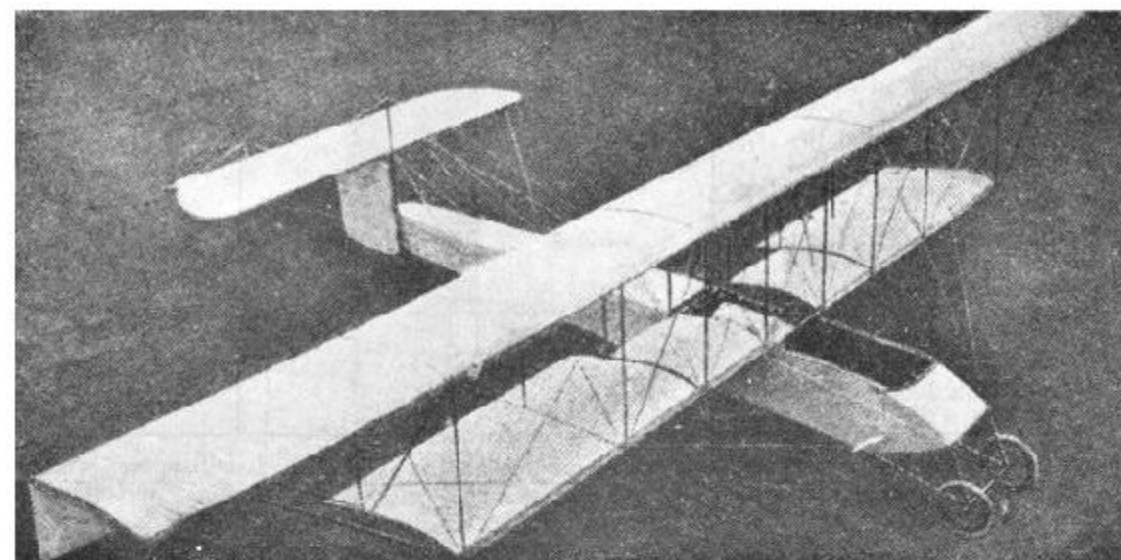

1913 hydro.

### SAVARY.

Soc. anonyme des aeroplanes. Robert Savary, 31 rue Dunois, Paris. School: Chartres. Output capacity: 100 to 150 machines a year.

Model and date.		1912. Biplane.	1912. Military (3-seater.)	1913. Biplane.
Length	feet (m.)	36 (11)	33-1/2 (10.15)	38-1/2 (11.70)
Span	feet (m.)	46 (14)	49 (14.90)	49-1/4 (15)
		33 (10)	37 (11.20)	33 (10)
Area	sq. feet (m <sup>2</sup> .)	510 (48)	533 (50)	550 (52)
Weight	machine lbs. (kgs.)	1132 (600)	...	1132 (600)
	useful lbs. (kgs.)	...	...	...
Motor	h.p.	various	70 Labor	75 Renault (Gnome or Labor)
Speed	max m.p.h. (km.)	56 (90)	...	59 (96)

min m.p.h. (km.)	50 (80)	...	...
Number built during 1912	...	47	...

Notes.—Wood and steel construction. *Control*: ailerons and rear elevator. Landing gear: wheels and skids. *Special features*: There are 4 rudders in the gap, and 2 tractors, chain driven. Aeroplatte fabric.

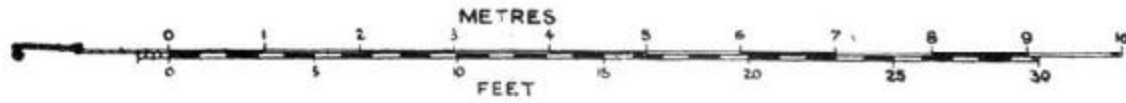
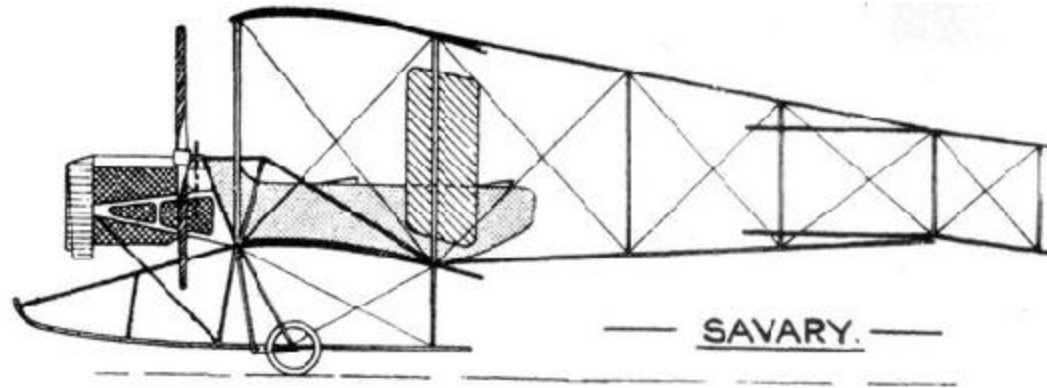

SAVARY. 1913. Uniform Aeroplane Scale

### SLOAN. "Bicurve."

Sloan & Cie, 17 rue de Louvre, Paris. Works: 9 rue Victor Hugo, Charenton. Flying ground: Port Aviation. Output capacity: small.

Model and date.		1912.	1913.
Length	feet (m.)	31-1/3 (9.50)	29 (8.70)
Span	feet (m.)	42-3/4 (13)	42-1/2 (12.90)
Area	sq. feet (m <sup>2</sup> )	527 (49)	473 (44)
Weight	machine lbs. (kgs.)	1100 (500)	662 (300)
	useful lbs. (kgs.)	...	...
Motor	h.p.	100 Gnome	120 Laviator
Speed	max. m.p.h. (km.)	59 (95)	65 (105)
Number built during 1912		...	...

Notes.—Wood construction. Wheels and skids landing gear. *Control*: ailerons and rear elevator.



Wood and steel construction. Landing: carriage wheels. *Control*: warping and rear elevator. Rectangular body.

Wood and steel construction. Landing: wheels and skids. *Control*: ailerons and front rear elevator.

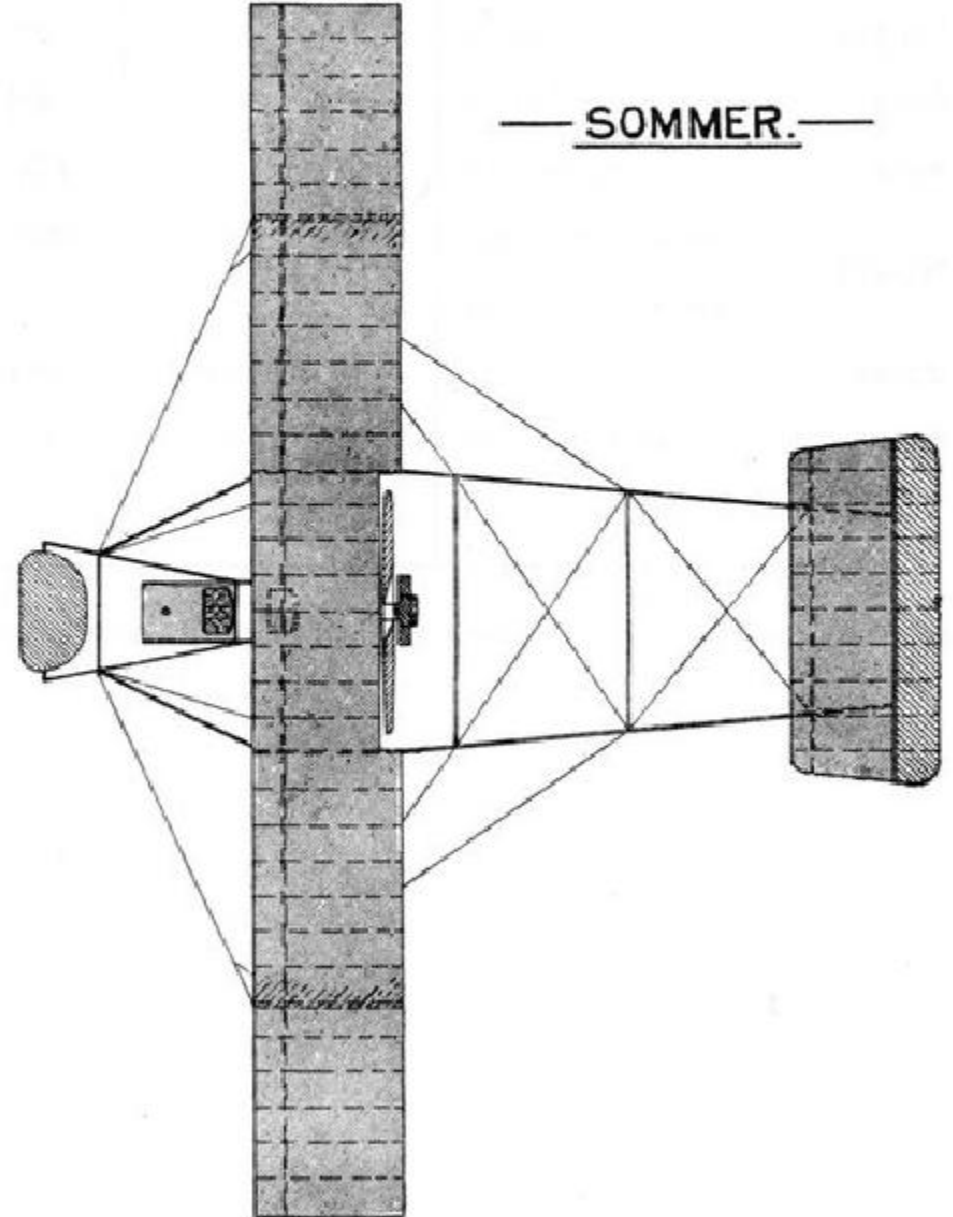
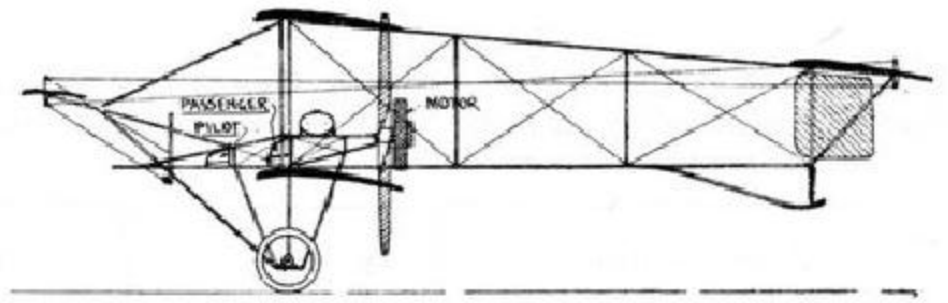

UNIFORM AEROPLANE SCALE.  
METRES.



## T

## TRAIN.

E. Train, Buoy, Camp de Chalons (Marne).

Model and date. <b>Monoplanes.</b>		1-seater.	2-seater.	Hydro-mono.
Length	feet (m.)	26-1/4 (8)	26-1/4 (8)	26-1/4 (8)
Span	feet (m.)	30-3/4 (9.30)	35 (10.66)	42-1/2 (12.94)
Area	sq. feet (m <sup>2</sup> .)	172 (16)	215 (20)	...
Weight	machine lbs. (kgs.)	573 (260)	617 (280)	...
	useful lbs. (kgs.)	...	...	...
Motor	h.p.	30/60 Anzani	70 Gnome	80 Gnome
Speed	max. m.p.h. (km.)	59 (95)	65 (105)	...
	min. m.p.h. (km.)	47 (75)	...	...
Number built during 1912		...	...	...

Notes.—Steel construction. Landing: carriage wheels and skids. *Control*: warping and rear elevator. The hydro has one very large float which extends a considerable distance ahead of the tractor.

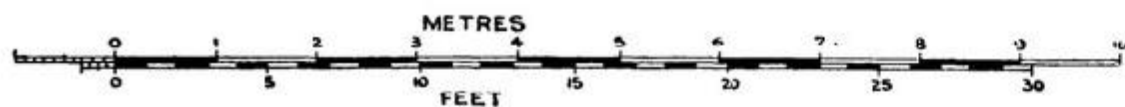
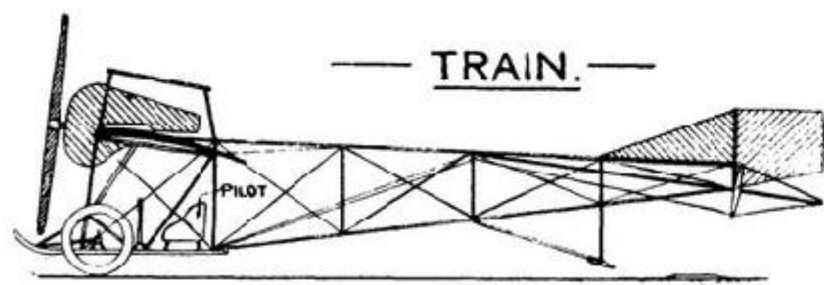

TRAIN. Uniform Aeroplane Scale

## TUBAVION.

Ponche &amp; Prinaud, Long.

Model and date.		Monoplane. 1913.
Length	feet (m.)	29 (8.85)
Span	feet (m.)	29-1/2 (9)
Area	sq. feet (m <sup>2</sup> .)	194 (18)
Weight	machine lbs. (kgs.)	772 (350)
	useful lbs. (kgs.)	...
Motor	h.p.	70 Gnome
Speed	max. m.p.h. (km.)	65 (105)
Number built during 1912		1

Notes.—Tubular steel construction. Landing: wheels and 2 very long skids. Propeller: amid-ships.

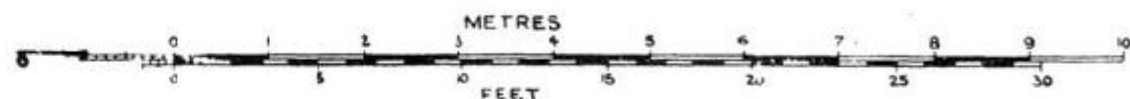
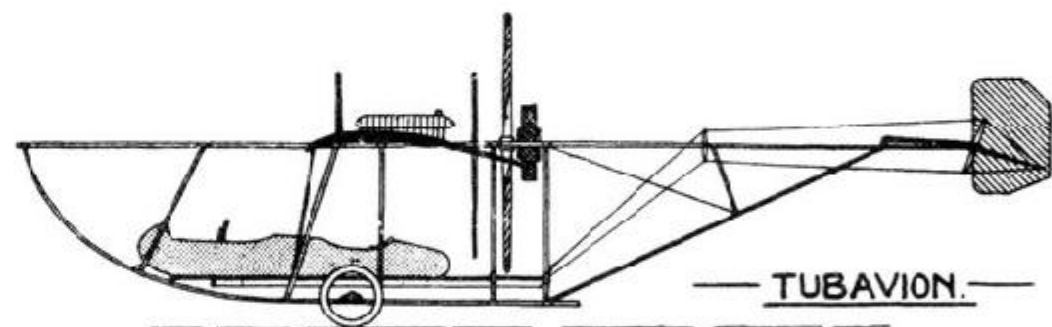

TUBAVION. Uniform Aeroplane Scale

## V

## VINET.

Gaston Vinet, 41-47 quai de Seine, Courbevoie: also 2-8 rue Larnac. Established for automobile work, 1893. Aeroplane output capacity: small.

Model and date.		Type D 1912 mono.	1913. Mono.
Length	feet (m.)	21-1/2 (6.60)	21 (6.40)
Span	feet (m.)	28-1/2 (8.60)	28 (8.50)
Area	sq. feet (m <sup>2</sup> .)	162 (15)	162 (15)
Weight	machine lbs. (kgs.)	550 (250)	440 (200)
	useful lbs. (kgs.)	...	...
Motor	h.p.	50 Gnome	50 Gnome
Speed	max m.p.h. (km.)	56 (90)	60 (95)
Number built during 1912		6	...

Notes.—Wood construction. Landing wheels and skids. *Control*: warping and rear elevator. Rectangular body. The two types are practically identical.

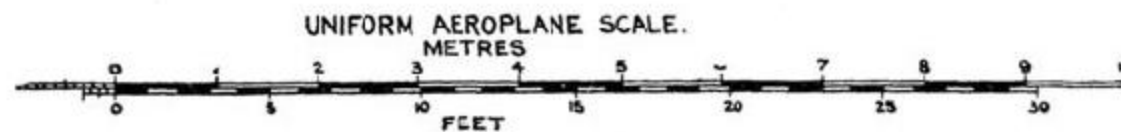
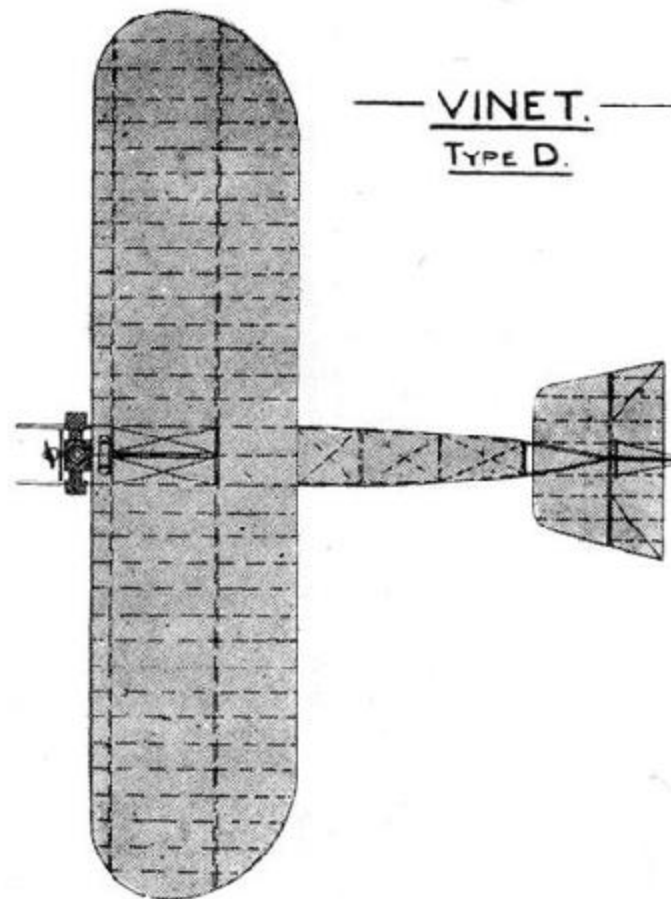
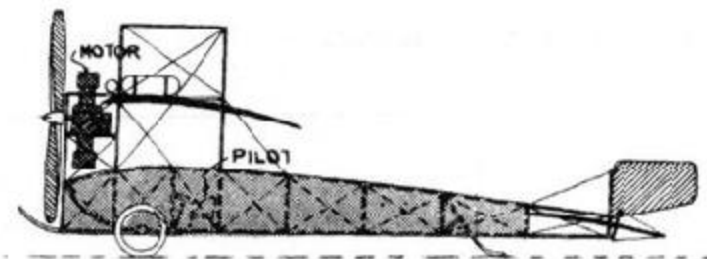

VINET. Type D. Uniform Aeroplane Scale

## VOISIN.

Voisin Aéroplanes, Boulevard Gambetta, Issy le Molineux, (Seine). School: Mourmelon. Capital 1,000,000 francs. The oldest aeroplane firm in the world, founded by the Brothers Voisin in 1905. (See past editions).

Latest models are:

Model and date.		Military biplane. Model 1912.	Hydro-biplane. Model 1912.	Military biplane. Model 1913.
Length	feet (m.)	37-3/4 (11.50)	36 (11)	32-3/4 (10)
Span	feet (m.)	55-3/4 (17)	43-1/4 (13.50)	45-1/3 (13.80)
Area	sq. feet (m <sup>2</sup> .)	387 (36)	376 (35)	398 (37)
Weight	total lbs. (kgs.)	1367 (620)	1212 (550)	1102 (500)
	useful lbs. (kgs.)	772 (350)	661 (300)	794 (360)
Motor	h.p.	70 Renault	100 Gnome	80 Gnome
Speed	max. m.p.h. (km.)	62 (100)	62 (100)	65 (105)
	min. m.p.h. (km.)	...	...	...
Number built during 1912		47	8	...

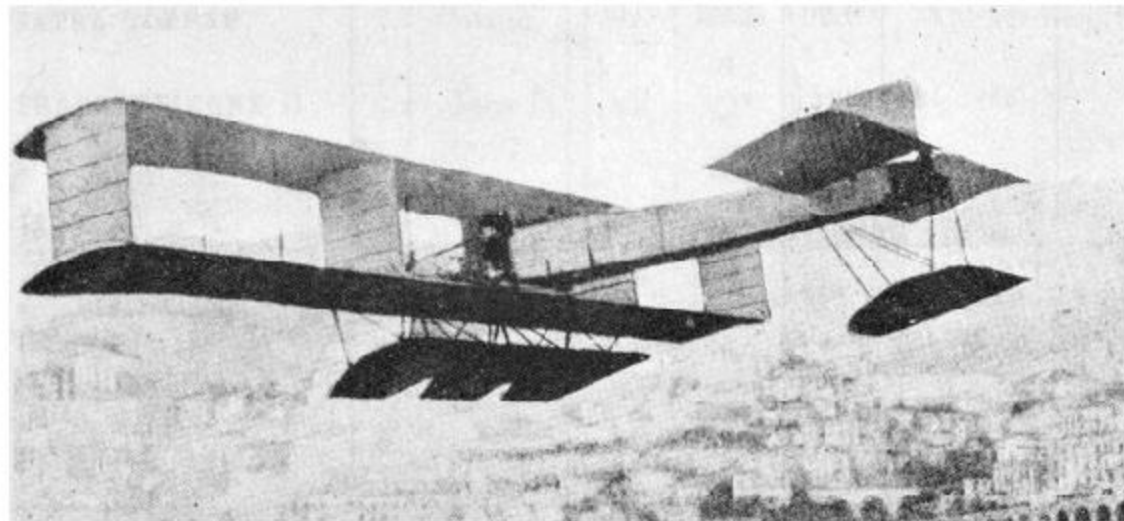

Canard with floats. By favour of "Aeronautics," U.S.A.

## Z

## ZODIAC.

Société Zodiac, 10 route du Havre, Puteaux pres Paris (Seine). Aero park: St. Cyr l'Ecole pres Versailles. Established 1896. Capital 850,000 francs.

Model and date.		S2. 1913.
Length	feet (m.)	38-3/4 (11.75)
Span	feet (m.)	49 (15)
	feet (m.)	36 (11)
Area	sq. feet (m <sup>2</sup> .)	350 (32)
Weight	machine lbs. (kgs.)	1010 (460)
	useful lbs. (kgs.)	551 (250)
Motor	h.p.	50 Gnome
Speed	max. m.p.h. (km.)	59 (95)
Number built during 1912		...

Notes.—Wood construction. *Control:* Ailerons and 1 rear elevator. Upper planes staggered 30 in advance of lower. Quadrilateral fuselage. Piloted passenger side by side. Landing carriage: 2 wheels and 1 skid. Aeroplante fabric.

The 1912 model was practically the same.

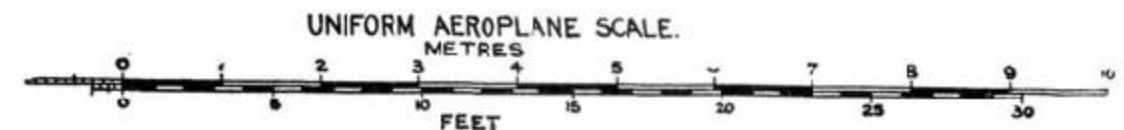
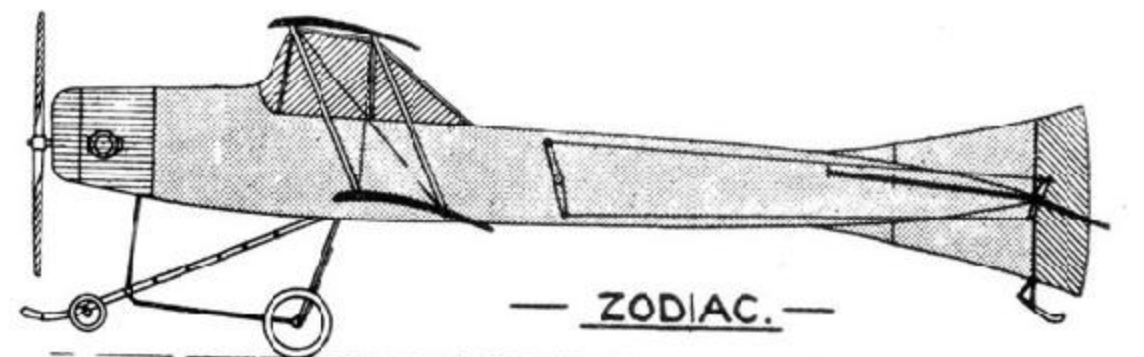

## FRENCH DIRIGIBLES.

## Military.



Date.	Name.	Make.	Type.	Capacity in m <sup>3</sup> .	H.P.	Speed. m.p.h. (K)	Notes.
1909	LIBERTÉ	Lebaudy	s.r.	4800	120	28 (45)	
1910	COL. RENARD	Astra	n.r.	4100	100	30 (50)	
1911	ADJUTANT REAU	Astra 10	n.r.	8950	220	32 (53)	
"	LIEUT. CHAURE	Astra 11	n.r.	8950	220	32 (53)	
"	ADJ. VINCENNOT	C. Bayard 4	n.r.	7500	75	29 (48)	
"	SELLE DE BEAUCHAMP	Lebaudy	s.r.	8000	75	30 (50)	
"	CAPT. MARÉCHAL	Lebaudy	s.r.	7500	160		
"	LE TEMPS	Zodiac 9	n.r.	2500	75	29 (48)	
"	CAPT. FERBER	Zodiac 10	n.r.	6000	180	33 (54)	
"	COMDT. COUTELLE	Zodiac 11	n.r.	9000	380	37 (60)	
1912	SPIESS	Zodiac 12	r.	11000	400	40 (65)	
"	FLEURUS	C. Bayard 5	n.r.	6500	150	36 (58)	
"	ECLAIREUR CONTÉ	Astra 12	n.r.	6640	75	28 (46)	
"	DUPUY DE LÔME	C. Bayard 6	n.r.	9700	244	35-1/2 (58)	
Building	A	Astra	?				
	B	C. Bayard 7	?				
	C	Lebaudy	?	17000	1000	43-1/2 (70)	
	D	Zodiac 13	?				

Pro.	7 new 20,000 c.m.		?			
			?			

**Military sheds** at Belfert, Epinal, Maubenge, Reims, Toul, Verdun (2).—Total 7.

During the year 1912 the principal work done was as follows:—

Name.	Hours out.	Distance travelled. m. (km.)	Gas used. m <sup>3</sup>
C. Ferber	152	3540 (5900)	45,500
Adj. Reau	105-1/2	2310 (3845)	81,000
Dupuy de Lôme	100	2655 (4424)	66,500
Adj. Vincennot	55	1340 (2235)	50,000
Le Temps	23	440 (700)	9,000
Fleurus	3-3/4	100 (159)	19,000

### Army Dirigible Pilots.

Airault, F.  
 Balny D'Avricourt  
 Baudry, A.  
 Bayard de Mendoca  
 Clerget, P.  
 Cohen, A.  
 Herbster, M.  
 Hirschaner, Col.  
 Juchmès, G.  
 Mugnier, Capt.  
 Noe, Martial  
 Périssé, Y.  
 Renard, Col. P.  
 Roussel, A.  
 Schelcher, A.

*Note.*—There are no dirigibles attached to the Navy.

### Private.

Date.	Name.	Make.	Type.	Capacity in m <sup>3</sup> .	H.P.	Speed. m.p.h. (k.p.h.)	Remarks.
1909	ASTRA	Astra 7	n.r.	4475	100	27 (43)	
1909	ZODIAC III	Zodiac 3	n.r.	1400	40	28 (45)	
1911	ASTRA TORRES	Astra	n.r.	1930	55	34 (56)	
1912	TRANSAERIENNE II	Astra 13	n.r.	9000	350	34 (56)	

**Private sheds** at Chalons-s-Marre, Issy (2), Lamotte-Breuil, Meaux, Melun, Mousson, Reims, Pau, St. Cyr (2).—Total 11.

32 sheds are building or projected by the National Aviation Committee.

Private Dirigible Pilots.

Capazza, Louis  
 Godart, Louis  
 Julliot, Henri  
 Kapferer, Henri  
 La Vault (de) Compte  
 Santo-Dumont, Albert  
 Surcouf, Edward

### ASTRA CLASS.

Astra Societe de Constructions Aeronautique, 13, Rue Couchot, and 121, Rue de Bellevue, Billancourt.

This Society was founded by Surcouf for the production of ordinary balloons. The first dirigible work was building part of the old *Lebaudy* in 1903, followed in 1906 by the *Ville de Paris*. The total number of dirigibles of this type completed by the end of 1912 stood at 14, one very large dirigible in hand for the French Army, and one small one for the British Navy, and another for the Russian Army.

Owing to changes in names, or owing to two names getting supplied to one ship, confusion frequently exists as to the names of the Astra dirigibles. The correct list is as follows:—

1.	Part of the LEBAUDY	1903
2.	VILLE DE PARIS	1906
3.	VILLE DE BORDEAUX	1908
4.	VILLE DE NANCY	1909
5.	<b>Russian Military dirigible, KOMMISSIONNY</b> , originally known as <b>CLEMENT-BAYARD I</b>	1909
6.	COLONEL RENARD	1909
7.	ASTRA-TRANSAERIENNE-VILLE DE PAU-VILLE DE LUCERNE <sup>[C]</sup>	1909
8.	ESPANA (Spanish Military)	1909
9.	VILLE DE BRUXELLES	1910
10.	LIEUT. CHAURE (French Military)	1911
11.	ADJUTANT RÉAU (French Military)	1911
12.	ECLAIREUR CONTÉ (French Military)	1912
13.	TRANSAERIENNE II	1912
14.	ASTRA-TORRES I	1911

<sup>[C]</sup> This ship has frequently figured as four different dirigibles.

The general features of the *Astra* class are: Non-rigid, weights distributed by means of a long girder hung under the gas bags, a long nacelle, and inflated stabilising shapes at the rear end of the balloon.

The *Astra-Torres* type are also non-rigid, but of trefoil section with a short nacelle.

The Compagnie Generale Transaerienne was first established in 1909 with *Transaerienne I*, and during the summers 1909, 1910 and 1911, this ship made a total of 273 ascents, carried 2590 passengers, and voyaged 7990 kilometres.

The Astra firm has dirigible hangers at Issy, Pau, Meaux, and Reims. Its constructional capacity is sufficient to build six dirigibles at any one time.

## FRENCH DIRIGIBLES

"ASTRA I-TRANSAERIEN-VILLE DE PAU-VILLE DE LUCERNE" (1909).

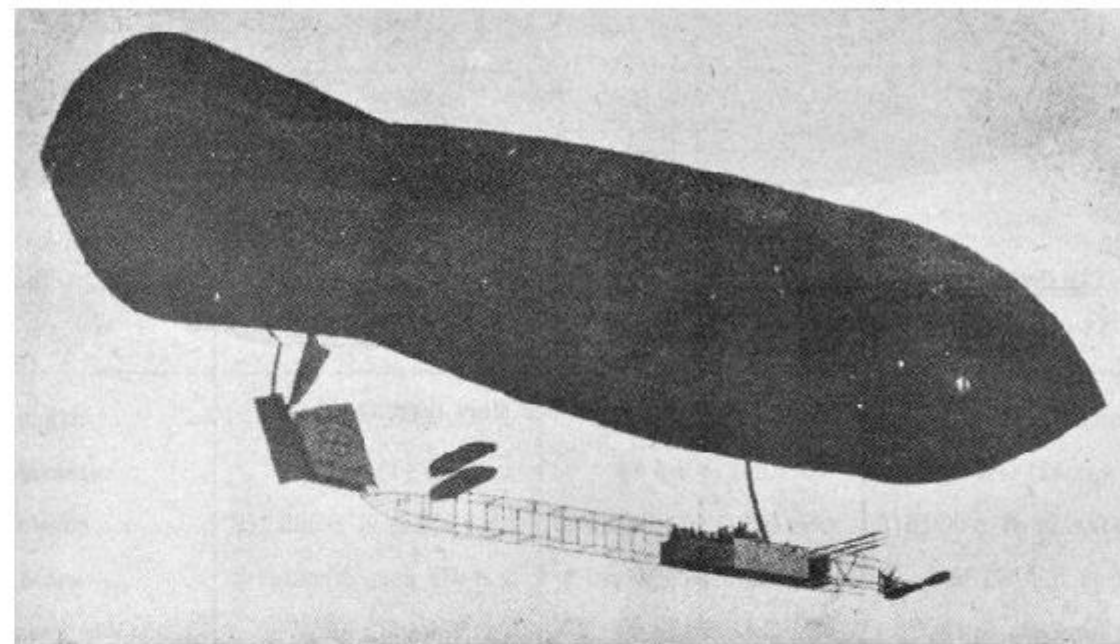

**Maximum length**, 197 feet (60 m.) **maximum diameter**, 40 feet (12.20 m.) **volume**, 158,000 c. feet (4,475 m<sup>3</sup>.)

**Total lift**.—Just over 7 tons=15,763 lbs. (7,150 kgs.) **Useful lift**, lbs. ( kgs.)

**Gas bags**.—Continental rubbered fabric, yellow.

**Motor**.—One 90-100 C. Bayard.

**Speed**.—27 m.p.h. (43 k.p.h.)

**Propellers**.—One.

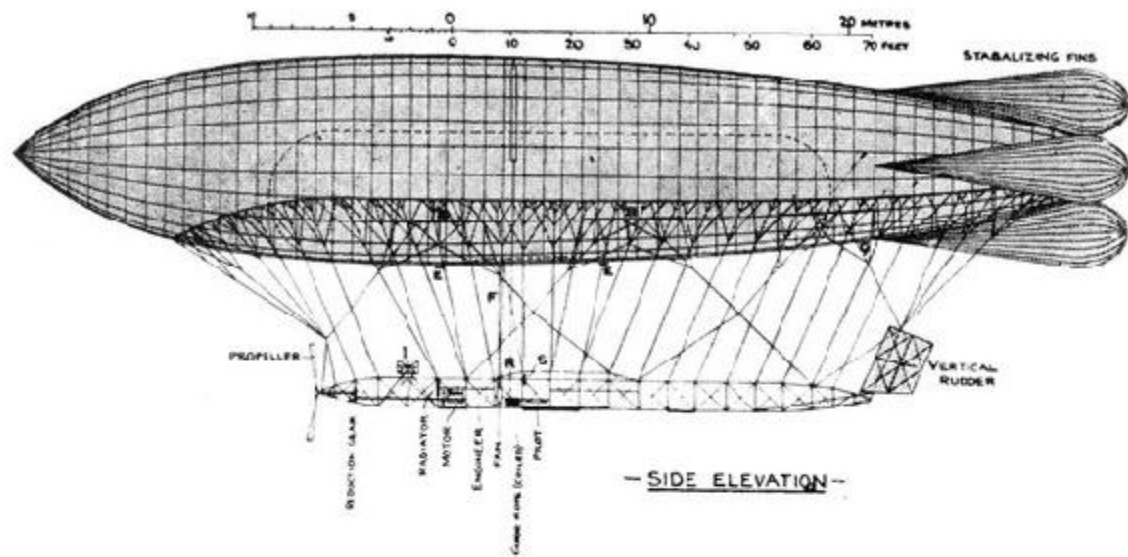

SIDE ELEVATION

### FRENCH DIRIGIBLES (Non-rigid)

COLONEL RENARD. Military (1909).

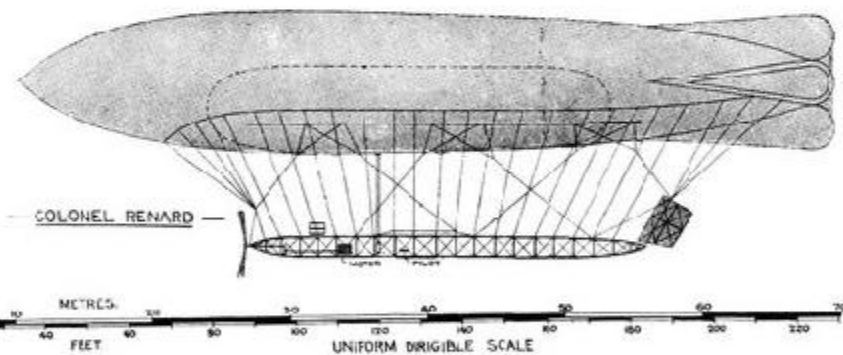

**Maximum length**, 213 feet (65 m.) **maximum diameter**, 35 feet (10.50 m.) **volume**, 145,000 c. feet (4,200 m<sup>3</sup>.)

**Total lift**.—9,921 lbs. (4,500 kgs.)=about 4½ tons.

**Gas bags**.—Yellow coloured rubber proofed Continental fabric.

**Motor**.—One 110 h.p. 4-cylinder Panhard.

**Speed**.—29 m.p.h.

**Propellers**.—1, at the front end of the car. "Integrale."

### Steering.—Elevators.

*Remarks*.—The two side stabilising shapes are duplicated, as they were in the *Ville de Paris*. A webbing stretched on steel tubes is introduced between the inner edges of the 4 main stabilising shapes to provide extra stabilising surface.

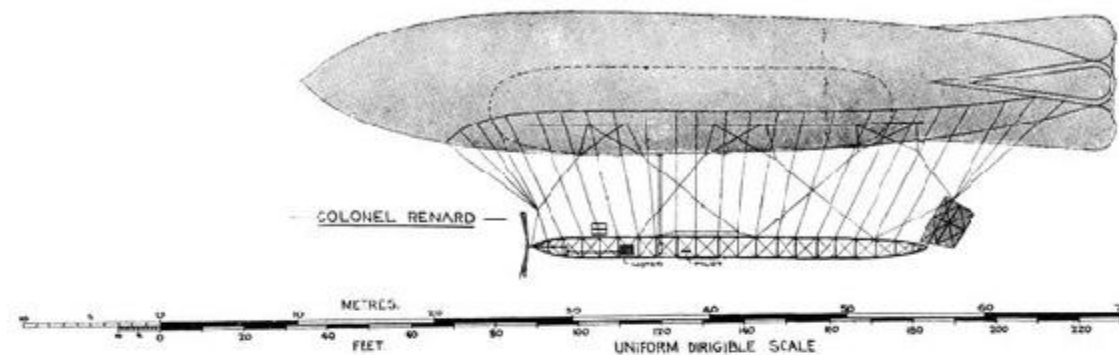

COLONEL RENARD. Uniform Dirigible Scale.

*Note*.—An elevator aft has since been added.

Improved *Col. Renard's* are:—

**LIEUT. CHAURE. Military (1911).**

**ADJUTANT RÉAU. Military (1911)**

**TRANSAERIEN II (1911).**

Particulars of these are as follows:—

	Lieut. Chaure.	Adjutant Reau.	Transaerien II.
Length	275-1/2 feet (83.8 m.)	285 feet (86.78 m.)	250 feet (76.25 m.)
Diameter	46 feet (14 m.)	46 feet (14 m.)	46 feet (14 m.)
Volume	312,550 c. ft. (8,850 m <sup>3</sup> .)	314,000 c. ft. (8950 m <sup>3</sup> .)	318,000 c. ft. (9,000 m <sup>3</sup> .)
Motors	2 Panhard, each 110 h.p.	2 Brasier, each 110 h.p.	2 of 175 h.p. each
Speed (p.h.)	32 m. (53 km.)	32 m. (53 km.)	34 m. (56 km.)

*Notes*.—All have 1 propeller forward of 6 m. diameter, and 2 aft of 3.70 m. The *Lieut. Chaure's* empenage is by ballonets; in the other two a cellular system and automatic stabilisation are the special feature.

Appearance practically the same as for *Colonel Renard*.

### ÉCLAIREUR CONTÉ. Military. (1912)

Nominal volume, 6,500 m<sup>3</sup>.

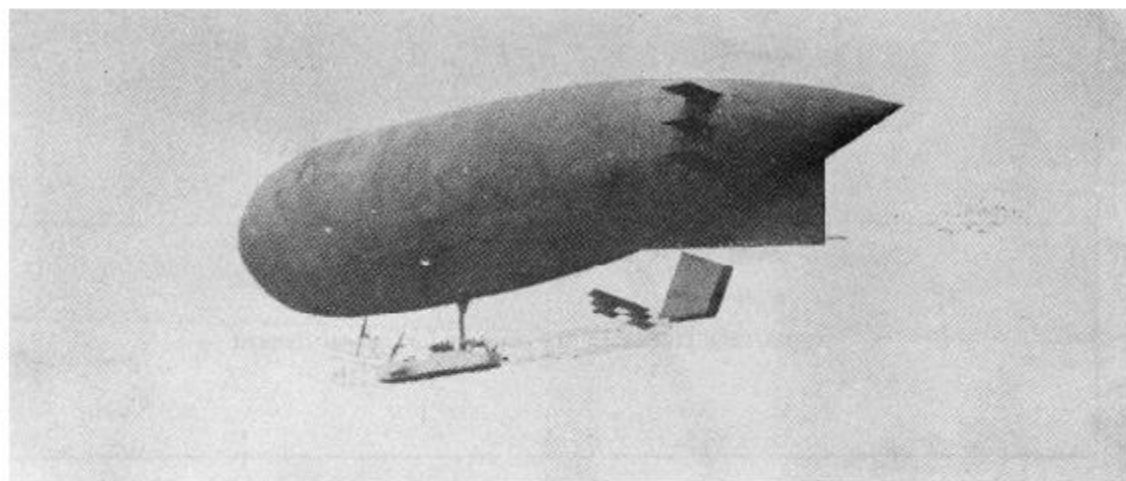

**Length**, 213 feet (65 m.) **diameter**, 46 feet (14 m.) **volume**, 234,500 c. feet (6,640 m<sup>3</sup>.)

**Ballonets**.—Volume, 71,770 c. feet (2,032 m<sup>3</sup>) empenage: cellular.

**Nacelle**.—Length, 115 feet (35 m.) Breadth, 5½ feet (1.60 m.) Height *about* 6 feet (2-1.50 m.)

**Motor**.—2 Chenu, 80 h.p. Hele-Shaw clutch.

**Speed**.—*About* 28 m.p.h. (43-45 km.p.h.)

**Propellers**.—2 central aft, each of 4 m. (13 feet) diameter. 650 r.p.m.

**Empeunage**.—Cellular, Stabilisation automatic.

**Notes**.—In this type the usual Astra style, rear of gas bag, is entirely done away with. Surface of each elevator is 18<sup>2</sup>, of the rudder 33 m<sup>2</sup>. There are 2 petrol reservoirs, each of 180 litre capacity.

Weights.

	lbs.	(kgs.)
Crew	838	(380)
Details	1367	(620)
Tools, etc.	220	(100)
"Lest d'altitude"	2205	(1000)
"Lest d'altitude" securité	661	(300)
Total	5291	(2400)

### ASTRA-TORRES I.

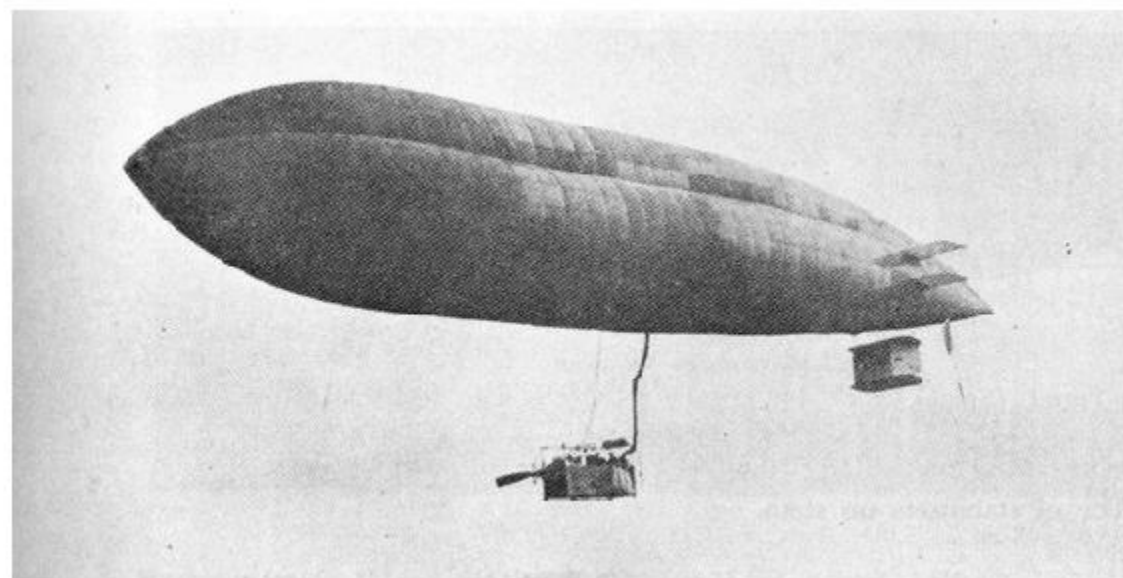

**Length**, 157 feet (47.72 m.) **diameter**, 33 feet (10 m.) **volume**, 68,150 c. feet (1,930 m<sup>3</sup>.)

**Ballonets**.—Volume, 11,300 c. feet (320 m<sup>3</sup>.)

**Nacelle**.—Length, 18 feet (5.50 m.) Breadth, 5 feet (1.50 m.) Height, 6½ feet (2 m.)

**Useful lift**.—1,219 lbs. (553 kgs.)

**Motor**.—1 Chenu, 55 h.p., at 1,380 r.p.m. Clutch, Ruban.

**Speed**.—31 m.p.h. (50 km.) **Endurance** *about* 5 hours.

**Propeller**.—1 in rear of nacelle. Diameter, 14¾ feet (4.50 m.)



*Notes.*—The special feature of this type is that it is constructed in three lobes, two below and one above. This particular ship is merely experimental, and is known as a "Vedette." Three models of it are to be obtained, (1) this 55 h.p. of 1,930 m<sup>3</sup>. volume. (2) a 75 h.p. of 2,000 m<sup>3</sup>. nominal volume. (3) a 110 h.p. of from 3,000-3,500 m<sup>3</sup>. volume. This latter is designed to have two propellers instead of one.

Larger editions of the type are also projected as follows:—

"Scouts:" 4500-6300 m<sup>3</sup>. of 200 h.p. (2 motors.)

"Transaeriens:" 7,000-8,000 m<sup>3</sup>. of 400 h.p. (2 motors.)

"Dreadnoughts:" 12,000 m<sup>3</sup>. or so, of 750 h.p. (4 motors.)

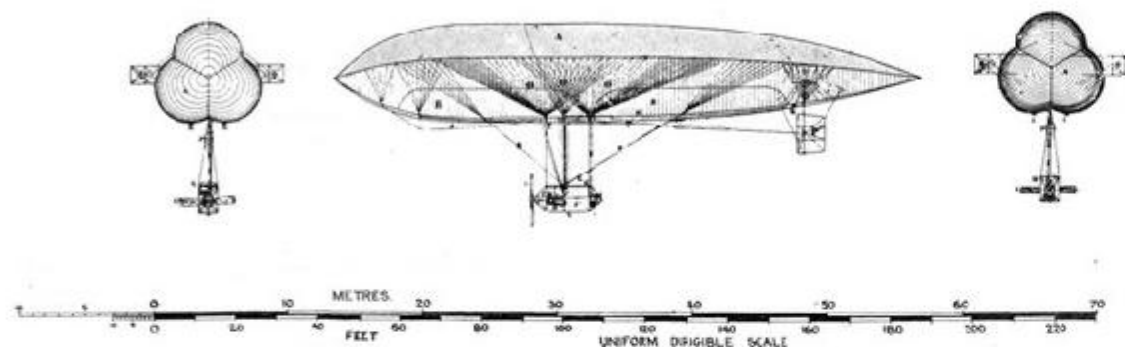

Uniform Dirigible Scale.

### CLEMENT-BAYARD CLASS.

Usines Clement-Bayard, 33, quai Michelet, Levallois-Perret (Seine).

These dirigibles closely resemble the *Astra* class in some main particulars; but (excepting *I*) differ from them in the sharp sterns and absence of stabilisers on stern.

The ships of this class are:—

1	CLEMENT-BAYARD	I (Kommissionny)	Russian Military
2	"	II	<b>British Military</b> (wrecked)
3	"		
4	"	IV ( <i>Adjutant Vincennot</i> )	French Military
5	"	V ( <i>Fleurus</i> )	"
6	"	VI	Private
7	"	VII	<b>French Military</b> ( <i>building</i> ), To be of 17,000 m <sup>3</sup> .

### ADJUTANT VINCENNOT. Military. (1911.) (Clement-Bayard IV.)

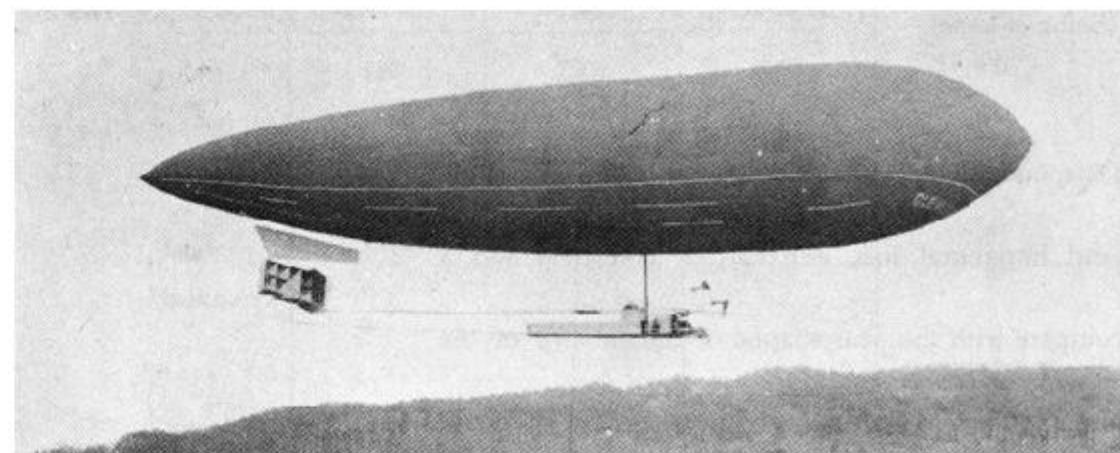

**Maximum length**, 251 feet (76.50 m.) **maximum diameter**, 43 feet (13.22 m.) **volume**, 7,500 m<sup>3</sup>.

**Total lift.**—Nearly 8 tons (8,000 kgs.) **Useful lift**, 2¾ tons (2717 kgs.)

**Gasbags.**—Continental rubbered fabric. Weight, 380 grammes per m<sup>2</sup>. Strength 1,000 kg. per metre. Leakage under 10 litres per m<sup>2</sup> per 24 hours.

**Motors.**—2 Clement motors, 4-cylinder, of 130 h.p., each placed on either side of the motor space.

**Speed.**—35 m.p.h. (56 km.)

**Propellers.**—2 Chauvière. Diameter, 19¾ feet (6 m.) Placed one on either side of the motors, well above the level.

**Steering.**—Vertical steering by means of a treble horizontal rudder over the rear end of the car. Horizontal steering by means of 2 vertical rudders placed one on each side of the rear horizontal rudder.

*Remarks.*—The feature of this *C.B.* type, which distinguishes it from the *Astra* ships of about the same size, is the arrangement of the propellers and the use of a 2 speed gear in connection with these. Normally each motor drives its own propeller through two sets of gearing connected by a Cardan shaft. On stopping one motor, the stopped motor is unclutched from its propeller shaft, which is then connected up by chain drive to the opposite shaft. The running motor is then put on to a "low gear," so that it can make the revolutions necessary for obtaining full power, while the propellers run slower than before. The ratio of "low gear" to "high" is 2 to 1, so that a single motor will be running under its best conditions when well throttled down.

A sister, *C. Bayard II* was sold to the British Army, and wrecked or dismantled, 1911.

## LIST OF WEIGHTS.

	kgs.
Gas bag	1,350
Valves (4)	45
Suspension	195
Girder (complete with fittings)	
Bow portion (6 m. long.)	128
Engine room (2.5 m.)	1,390
Bridge and passenger space (12 m.)	957
After part (18 m.)	182
Raised tail (4.5 m.)	63
2 Propeller brackets	378
2 Propellers	230
Rudders	150
Water	140
Trail ropes	75
Total	5,283
Lift	8,000
Balance, for ballast fuel, oil, crew	2,717

**FLEURUS. Military. (C.B. V.) (1912.)****C. BAYARD VI. (Private.) (1913.)**

These two are slightly smaller sisters of the *Adjutant Vincennes*.

**FRENCH DIRIGIBLES (Semi-rigid).****LEBAUDY CLASS.**

Ateliers Lebaudy Frères, Moisson, par La Roche-Guyon (Seine-et-Oise).

**DISTINCTIVE CHARACTERISTICS:**

The cars are short and suspended from a long keel which is suspended close up to the gas bag, and is mostly covered in with fireproof canvas.

The rear end of the keel is expanded into fixed vertical and horizontal fins, and carries a vertical and a horizontal rudder.

The rear end of the gas bag is fitted with thin fixed planes (compare with the pear shaped or tubular fins of the "Astra" class).

The cars are provided underneath with an extraordinarily strong conical structure, which takes the shock of striking the ground and distributes it over the whole car.

Aeroplanes are now fitted, one each side of the keel, well forward.

Ships of this class which have been built:—

	LEBAUDY I	French Military Airship.	Rebuilt 1909 into <i>Lebaudy II</i> .	now discarded
1.	LEBAUDY II	"	Original <i>Lebaudy I</i> rebuilt. <b>Known as Le Jaune.</b>	now discarded
2.	PATRIE		Lost in a storm.	
3.	REPUBLIQUE	French Military Airship.	Wrecked Autumn, 1909.	
4.	LA RUSSIE	Sold to Russian Government.	Now <i>Lebed</i> .	
5.	LIBERTÉ	French Military Airship.		
6.	CAPITAINE MARECHAL	"		
7.	"MORNING POST"	British Military.	( <i>Lebaudy III</i> .) Wrecked 1911	
8.	LIEUT. SELLE DE BEAUCHAMP.	French Military Airship.		
9.	New ship of 17,000 m <sup>3</sup> building.	"		

To Lebaudy designs:—

ONE Austrian Military  
Airship.

Name	LIBERTÉ	CAPITAINE MARÉCHAL.	SELLE DE BEAUCHAMP.	New ship. <i>Building.</i>	
Date	1909.	1911.	1911.	1913-14.	
Service	Military.	Military.	Military.	Military.	
Volume	c. feet (m <sup>3</sup> )	4800	7500	8000	17,000
Length	feet (m.)	220 (67)	279 (85)	292 (89)	
Diameter	feet (m.)	35-1/2 (10.80)	42 (12.80)	48 (14.00)	
Gasbags	fabric	Lebaudy	Lebaudy	Lebaudy	
	ballonets	1	...	...	
Lift	total tons	4-1/2	...	9	
	useful tons	...	...	...	
Motors	h.p.	1--135 Panhard	2--80 Panhard	2--80 Panhard	
Propellers	number	2 wood	2 wood	2 wood	
	blades	2	2	2	
	diam. feet (m.)	...	16-1/2 (5)	16-1/2 (5)	
Speed	max. m.p.h. (km.)	31 (50)	28 (45)	28 (45)	
Endurance	hrs.	...	...	...	
Complement		...	...	5	

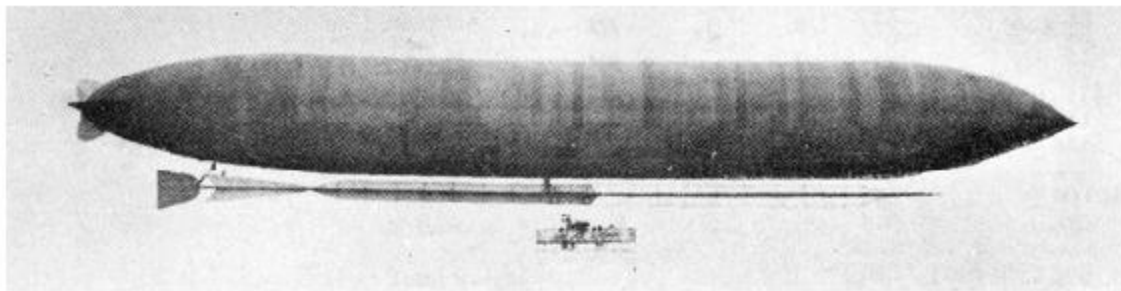
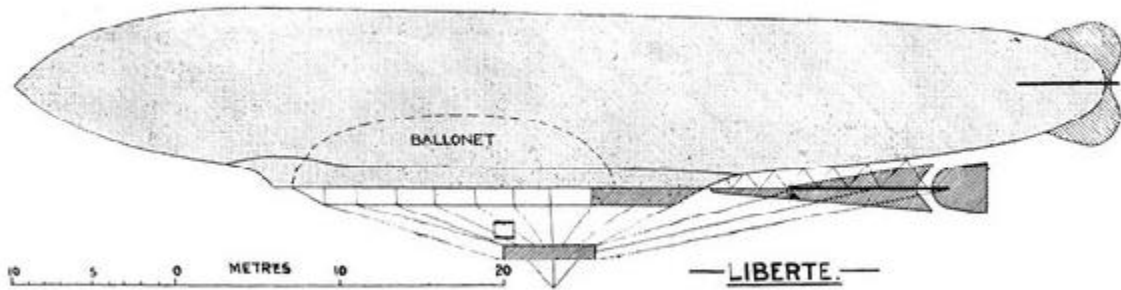
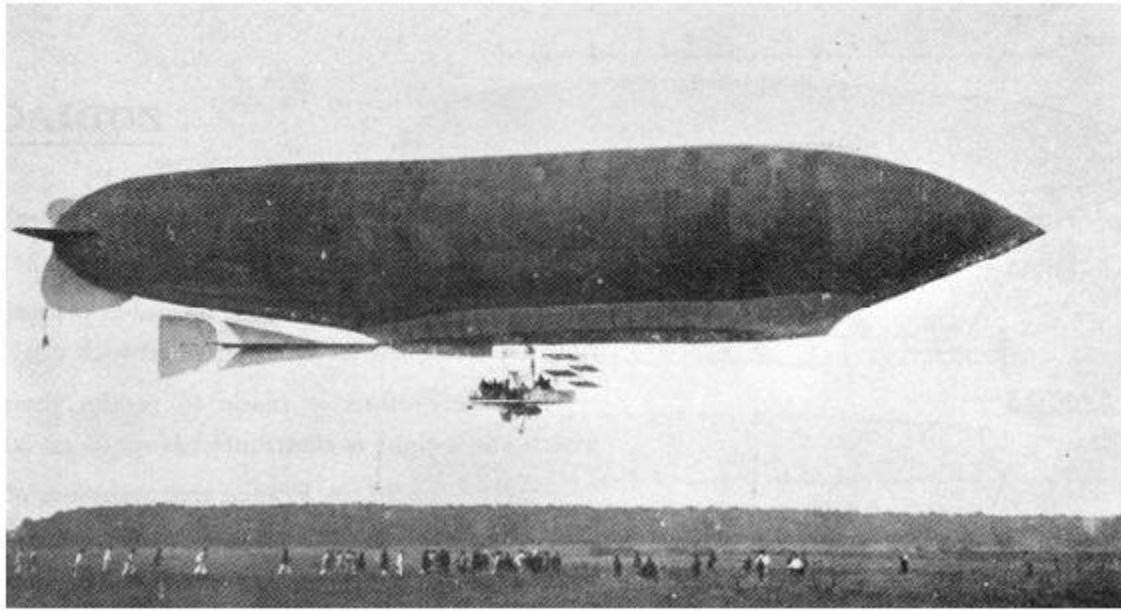

## FRENCH DIRIGIBLES (Non-rigid).

### ZODIAC CLASS.

Société française de ballons dirigeables et d'aviation, Zodiac, 10 route du Havre, Puteaux (Seine).

These dirigibles were intended primarily for private pleasure purposes. Consequently they are designed to fly when filled with coal gas if necessary.

Every effort is made to render them easily transportable; the long girder frame by which the weight is distributed is made to take to pieces.

It is held in France that numbers of this class of vessel would form an invaluable asset in time of war, as each could be transported in a single cart, filled with a very few bottles of hydrogen, and when so filled could manuvre for some 6 hours at a speed which compares favourably with that of the standard types.

When the service of reconaissance was performed, the vessel could be packed up and sent out of harm's way in an hour, whereas this could scarcely be done with a larger vessel on account of the quantity of hydrogen that would be required if it had to be filled afresh for each service. The mooring of an airship in the open during war requires such an amount of preparation and attention as to be a serious drawback to the alternative plan of keeping such vessels unfilled, while the sending of an airship back to its distant shed on each occasion means doubling the work that the ship is called upon to perform.

Ships of class are:—

- |     |   |                          |
|-----|---|--------------------------|
| 1.  | <b>ZODIAC I</b> ( <i>Petit Journal</i> )        |                          |
| 2.  | <b>ZODIAC II</b> ( <i>De la Vaulx</i> )         |                          |
| 3.  | ZODIAC III                                      |                          |
| 4.  | ZODIAC IV                                       | Dutch Military           |
| 5.  | ZODIAC V  | South American (private) |
| 6.  | ZODIAC VI                                       | Sold to United States    |
| 7.  | ZODIAC VII                                      | Sold to Russian Army     |
| 8.  | ZODIAC VIII                                     | "                        |
| 9.  | <b>ZODIAC IX</b> ( <i>Le Temps</i> )            | French Army              |
| 10. | <b>ZODIAC X</b> ( <i>Capitaine Ferber</i> )     | "                        |
| 11. | <b>ZODIAC XI</b> ( <i>Commandant Coutelle</i> ) | "                        |
| 12. | <b>ZODIAC XII</b> ( <i>Spiess</i> )             | " ( <b>rigid</b> )       |

## ZODIAC III.

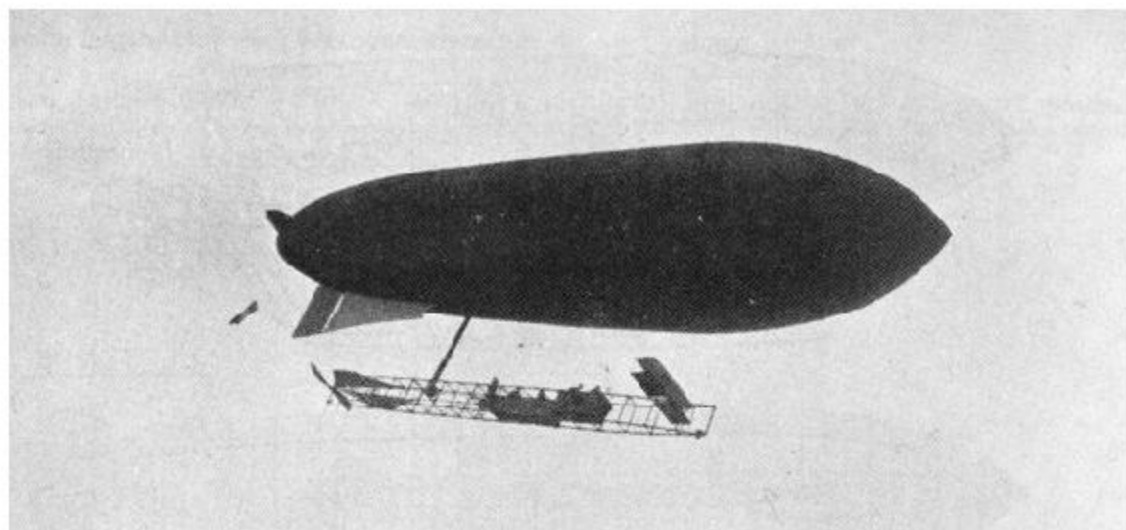

**Maximum length,** 134 feet (40.8 m.) **maximum diameter,** 28 feet (8.5 m.) **volume,** 1,400 m<sup>3</sup>.

**Total lift.**—1½ tons (1,540 kgs.) **Useful lift,** lbs. ( kgs.)

**Gas bags.**—Light continental rubbered fabric.

**Motor.**—Ballot, 4-cylinder, 40-45 h.p., 1,200 r.p.m.

**Speed.**— m.p.h. (45 km.p.h.)

**Propellers.**—Driven at 600 r.p.m. Integral type, 12¼ feet (3.75 m.) in diameter. Pitch, 6½ feet (2 m.) in rear of the car.

**Steering.**—Vertical balanced rudder in rear of the vertical fin, under the rear of the gas bag. Double elevator above the fore end of the car. Horizontal fins of material spread on iron frames on either side of the rear end of the car.

**Remarks.**—The car consists of a 130 feet (40 m.) long wooden girder, which can be divided into 4 separate parts of 13 feet (4 m.) each. The suspension is by steel wires fitted with adjusting screws at the lower ends and toggles at the upper ends, by which they connect to the crows' feet which are sewn to the suspension strips.

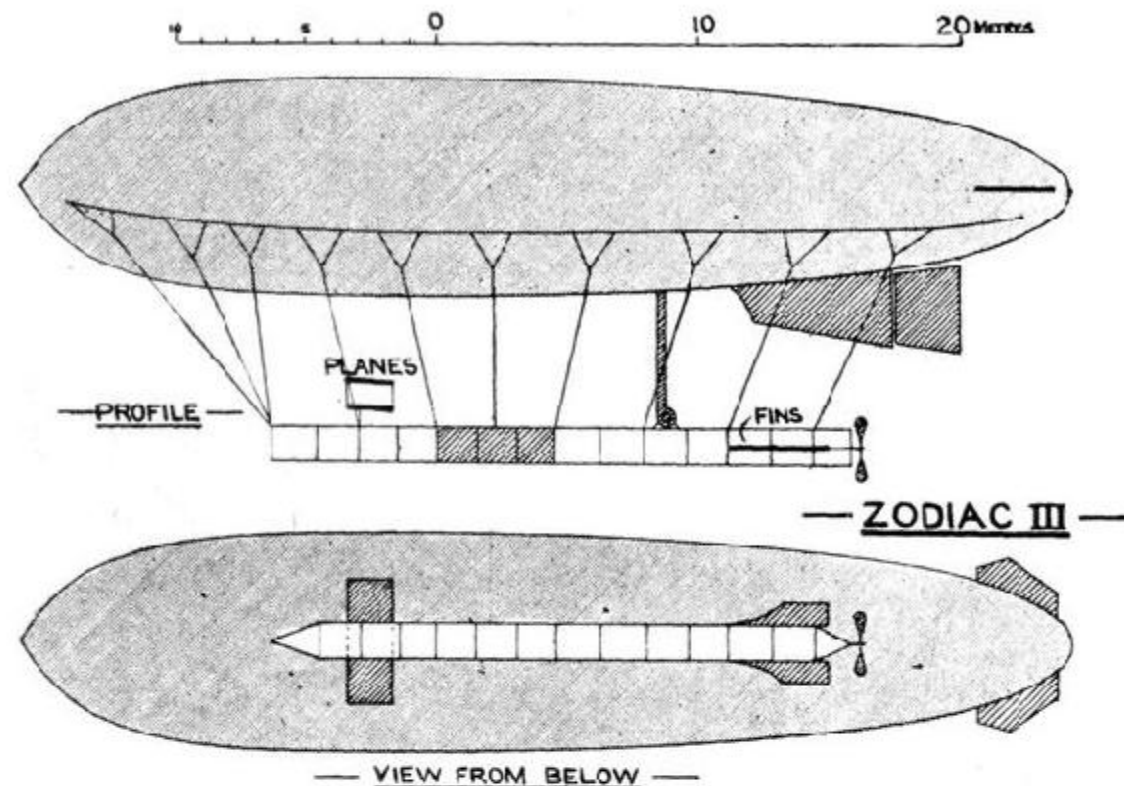

ZODIAC III.

### DETAILED WEIGHTS OF ZODIAC III.

	kgs.	lbs.
Gas bag ( <i>including</i> ballonnet)	330	727½
Valves	12	26½
Suspension wires and gear	15	33
Tail fins	24	53
Horizontal rudder	10	22
Vertical rudder	10	22
Girder car	168	370¼
Motor ( <i>including</i> pump, magneto, lubricating gear, etc.)	275	606¼
Motor bearer and gear	22	48½
Petrol tank	10	22
Radiator	25	55
Reduction gearing	12	26½

Shafting	15	33
Fan	9	20
Steering gear	5	11
Water	8	17¼
Petrol	20	44
Miscellaneous: 4 men	300	661
Total	1,270	2,800 <i>about</i>
Ballast	270	595
Total weight	1,540	Total lift 3,395

**LE TEMPS. Military. (Alias ZODIAC IX.)**

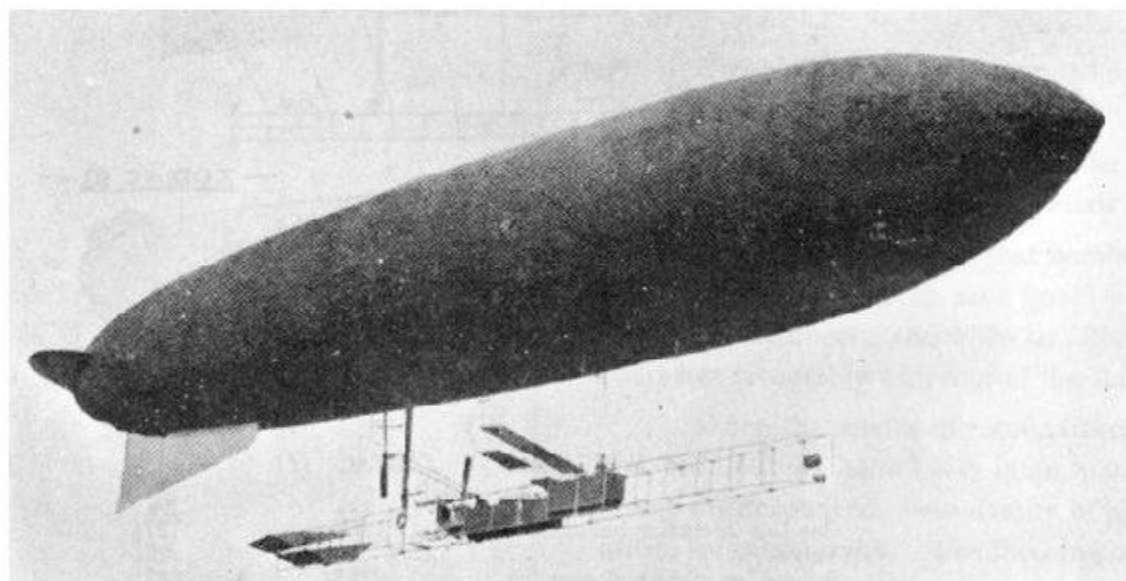

**Maximum length**, 164 feet (50.25 m.) **maximum diameter**, 29½ feet (9 m.) **volume**, 81,250 cubic feet (2,300 m³.)

**Total lift.**—

**Gas bag, etc.**—2 ballonets, each of 257 m³.

**Motor.**—Dansette-Gillet. 60 h.p.

**Propellers.**—2, chain driven, one on either side of car.

**Speed.**—

**Steering.**—Elevator in nacelle amidships. Rudder aft.

**Remarks.**—

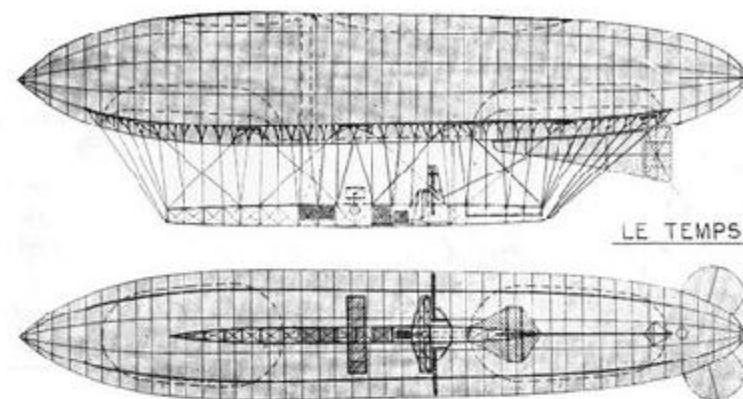

LE TEMPS. Uniform Dirigible Scale.

**CAPITAINE FERBER. Military. (Alias ZODIAC X.)**

**Maximum length**, 249-1/3 feet (76 m.) **maximum diameter**, 40½ feet (12.36 m.) **volume**, 6,000 m³.

This ship has 2 ballonets of 650 m³. each, and a car 35×13×2 m., made up of 5 sections. 2 **motors**. Dansette-Gillet, 90 h.p., each actuating 2 propellers (4-bladed), geared to 500 r.p.m. Carries petrol for 15 hours work. Completed 1911.

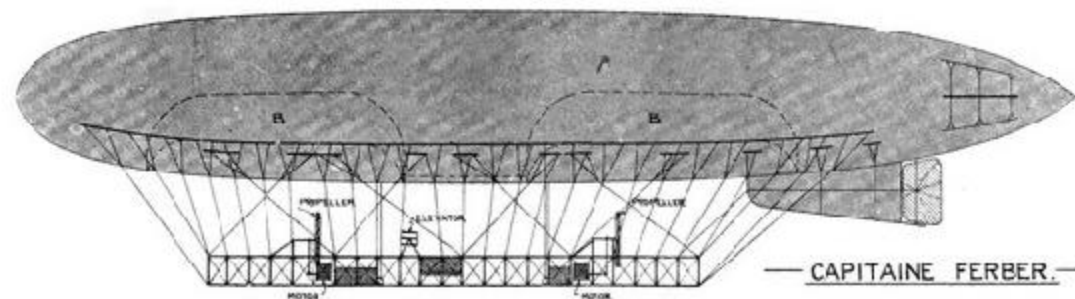

Photo, Branger.

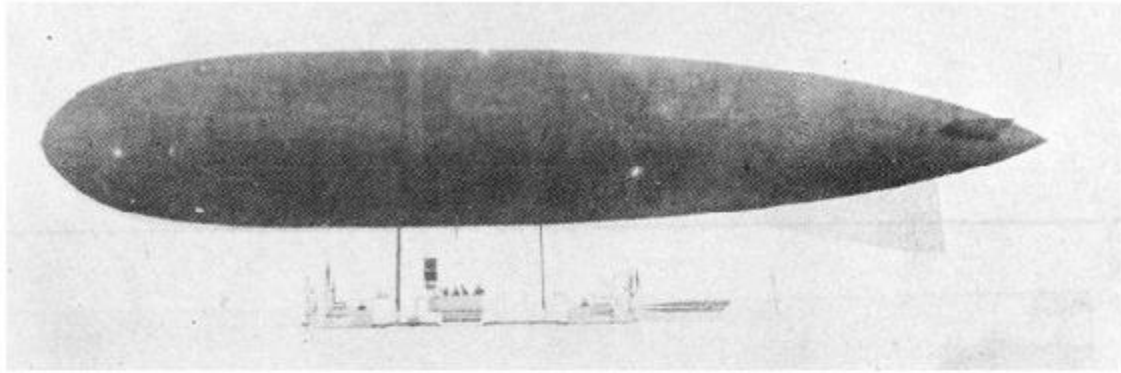

CAPITAINE FERBER. Uniform Dirigible Scale.

**COMMANDANT COUTELLE. Military.**  
(ZODIAC XI.)

(Enlarged *Captaine Ferber.*) Building.

**Maximum length,** 292 feet (89 m.) **maximum diameter,** 46 feet (14 m.) **volume,** 9,000 m<sup>3</sup>.

**Gas bags, etc.**—2 ballonnets, each 45,900 c. feet (1,300 m<sup>3</sup>.)

**Nacelle.**—Nickel steel in 5 sections. Length, 131¼ (40 m.) Width, 4½ feet (1.30 m.) Hung 16½ feet (5 m.) below the balloon. Pilot in centre. Carries a total crew of six, petrol and oil for 15 hours' continuous work at full power.

**Motors.**—2, each of 190 h.p.=total of 380 h.p. Placed one at either end of the nacelle.

**Propellers.**—4, of 15 feet (4.50 m.) diameter. Two geared to each motor to half engine speed.

**Speed (expected).**—37 m.p.h. (60 k.p.h.)

**ZODIAC XII. Rigid. Military.**  
(SPIESS.)

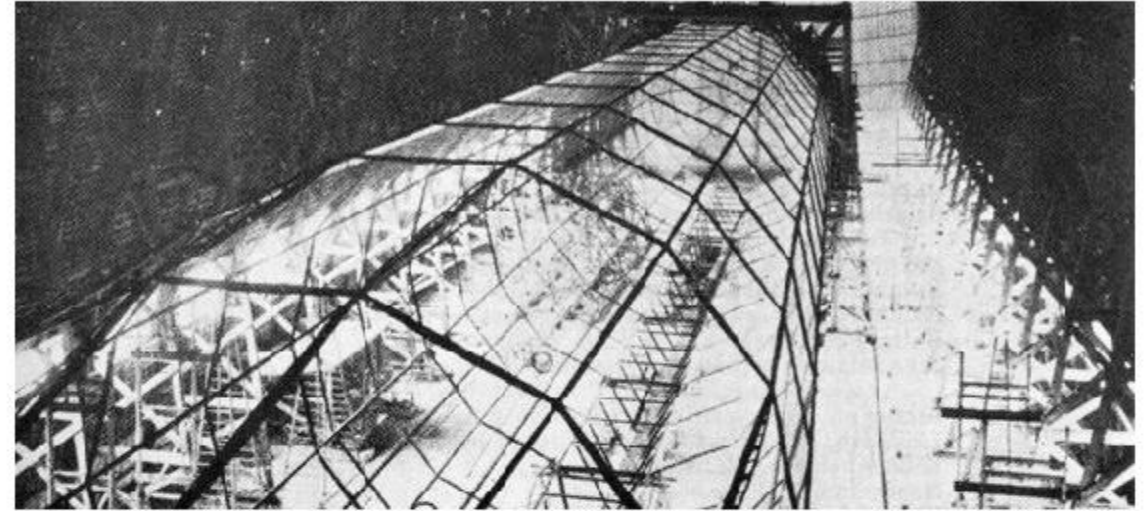

*Spiess. Building.* Photo, Branger.

**Maximum length,** 341 feet (104 m.) **maximum diameter,** 42¾ feet (13 m.) **volume,** 11,000 m<sup>3</sup>.

**Gas bags.**—Sections 11. Number of cylindrical sections 8. Number of sides to polygon 14.

**Motors.**—Two 6-cylinder 200 h.p. in each nacelle, each driving 2 propellers of 15 feet (4.50 m.) diameter.

**Speed.** (expected)—40 m.p.h. (65 k.p.h.)

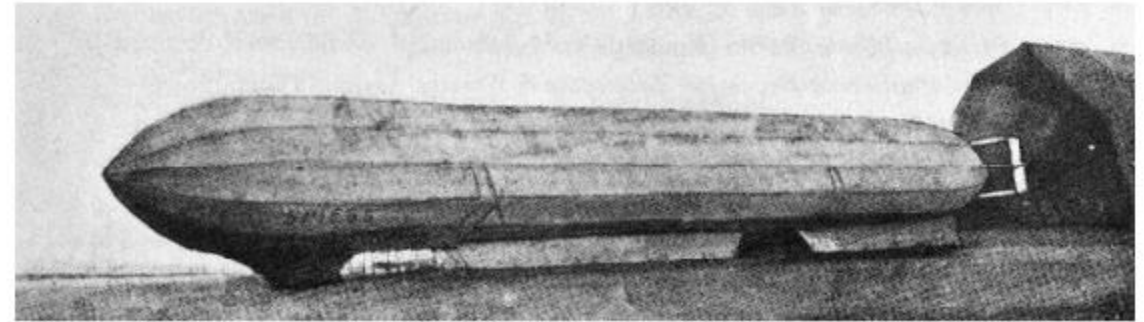

## GERMAN.

(By our special German editor.)

### Aerial Journals:—

*Deutsche Luftfahrer Zeitschrift für Luftschiffahrt* Berlin, W. (Fortnightly).  
*Allgemeine Automobil Zeitung*, Berlin (Weekly).  
*Automobil Welt*, Berlin (Thrice Weekly).  
*Das Deutsche Auto*, Munich (Weekly).  
*Die Luftflotte*, Berlin (Monthly).  
*Internationale Revue für Autowesen & Aviatik*, Leipzig (Fortnightly).  
*Flugsport*, Frankfurt (Fortnightly).  
*Motor*, Berlin (Monthly).  
*Der Motorwagen*, Berlin (Thrice Monthly).  
*Monatshefte der Reichsfliegerstiftung*, Charlottenburg (Monthly).  
*Zeitschrift für Flugtechnik & Motorluftschiffahrt*, Berlin (Fortnightly).

### Private Flying Grounds (Military see further on):—

**Adlershof**, Teil des Flugfeldes Johannisthal (*Wright School*).  
**Bork**, Post Brück in der Mark (*Mars School*).  
**Burg bei Magdeburg** (*Schulze School*).  
**Darmstadt** (Truppenübungsplatz).  
Dotzheim bei Wiesbaden.  
**Frankfurt a.M.** (*August Euler*).  
**Fühlungen bei Köln** (Kölner Club für Flugsport).  
**Garching b. München** (*Hoffman-Harlan*).  
**Griesheim b. Frankfurt a.M.** (Frankfurter Flugsport-Club & Flugtechn. Verein).  
**Habsheim b. Mülhausen i.E.** (*Aviatik*).  
**Hainberg b. Nürnberg** (Flugtechn. Ges. Nürnberg-Fürth).  
**Hamburg** (*Grade*).  
**Holten. Niederrh. Verein f.L.** (*Hilsmann*).  
**Johannisthal b. Berlin** Flugschule *Albatros, Dorner, Harlan, Fokker*, Luftverkehrs-ges. m.b.H.,  
*Rumpler & Wright*.  
**Kitzingen in Bayern**, 1911 (Hildebrand & Schroth).  
**Lindenthal b. Leipzig.** (School for Deutschen Flugzeugwerke).  
Loddenheide b. Münster.  
Meerheimb b. Köln.  
**Milbertshofen b. München** (Dr. Wittenstein).

**Neuenlande b. Bremen** (*Müller-Aviatik*, Bremer v.t.L.)  
**Niederwalluf**, 1911 (*Goedecker*).  
**Oberwiesenfeld bei München** (*Gustav Otto*).  
Puchheim b. München.  
Reichenberg-Boxdorf b. Dresden.  
**Schneverdingen** (*Oertz*).  
**Schulzendorf b. Berlin** (*A.E.G.*)  
**Strassburg i.E.**, "Polygon" (*E.E.C. Mathis*).  
Suechteln.  
Teltow bei Berlin.  
**Velten bei Berlin** (*A.E.G.*)  
**Wandsbek**, Exerzierplatz, 1911 (*Rumpler und Jordan*).  
**Weimar** (*Wright*).  
**Wustenbrand b. Chemnitz** (Flugtechn. Ges. in Chemnitz).  
**Zahlbach b. Mainz** (School for Aut. & Flugtechnik).

## GERMAN AERIAL CLUBS.

### Aerial Societies:—

Aachener V. f. L. Aix la Chapelle.  
Aero Club (Imperial), 3, Nollenderfplatz, Berlin. Sec.: H. Von Frankenberg und Ludwigsdorf.  
Akademie für Aviatik, Munich.  
Allgemeiner Deutscher Automobil Club, Munich.  
Anhaltischer V. f. L. (E. U.) M. Antoineatten str. 22a, Dessau.  
Augsburger Verein für Luftschiffahrt, Augsburg.  
Automobil-und Flugtechnische-Gesellschaft (E. V.) Nurnberger Platz 5, Haupyverein Berlin,  
Hochster Str. 1, Bezirksverein Frankfurt a. M, Neuer Wall 44, II, Hamburg.  
Bayerischer A. K. Munich.  
Berliner V. f. L., Berlin.  
Biltefeldt V. f. L., Bilterfeld.  
Braunschweigische V. f. L.  
Breisgau V. f. L., Freiburg.  
Bremer V. f. L. (E. V.) N. W., Obernstr, 52/54 I, Bremen.  
Bromberger V. f. L. (E. V.) O, Gasanstalt, Bromberg, Stadt.  
Chemnitzner V. f. L.  
Deutsche Touring Club, Munich.  
Deutscher Luftflotten Verein, Mannheim.  
Dusseldorfer Luftdahrer-Klub (E. V.) W. Dusseldorf, Breite Str. 25, I.  
Erfurter V. f. L. (E. V.) M. Dalversweg 24, Erfurt.  
Flugverein Neustadt a. d. Haardt, S. W., Neustadt, I.  
Flugzeugkonvention des V. D. M. L., Potsdamer Str. 121 H, III, Berlin W.  
Frankfurter Flugsport-Club (E. V.) Neue Mainzer Str. 76, Frankfurt a. M.



Frankfurter Flugtechn, Verein (E. V.) Bahnhofplatz 8, Frankfurt a. M.  
Frankfurter V. f. L. (E. V.) S. W. Kettenhofweg 136, Frankfurt, a. M.  
Frankischer V. f. L. (E. V.) S. Kurschnerhof 6, Wursburg.  
Hamburger V. f. L. (E. V.) N. W., 36, Colonnaden 17-19, Hamburg.  
Hannoverscher V. f. L. (E. V.) N. W., Lortzingstr. 6, Hannover.  
Hereforder Verein fur Lufthahrt, Bahnhofplatz, Alfermann, Herford.  
Hildesheimer V. f. L., Hilkesheim, Lucienvorder str. 22.  
Kaiserlicher Aero-Club, K. Nollendorfplatz 3, Berlin W.  
Kaiserlicher Automobil-Club, K, 9 Leipzigerplatz 16, Berlin W.  
Karlsruher Luftfahrt-Verein (E. V.) S. W., Bachstr, 28, Karlsruhe.  
Kolner Club, f. L. (E. V.) W. Bischofsgartenstr. 22, Koln.  
Koniglich Bayerischer Automobil-Club, B. Brienner str. 5 I, Munchen.  
Koniglicher Sachsischer V. f. L. (E. V.) Sa, Ferdinandstr. I, Dresden.  
Kurhessischer V. f. L. (E. V.) S. W., Physikalisches Institut, Marburg ad Lahn; Cassel Sektion, Kolnische str. 84, Cassel.  
Leipziger V. f. L. (E. V.) Sa, Markt 1, Leipzig.  
Lubecker V. f. L. (E. V.) N. W., Israeldorfer Allee 13a, Lubeck.  
Luftshrverein Gotha (fruther Reichsflugverein Gotha), Gotha, I.  
Luftfahrtverein Touring-Club, Pranner str. 24, I. Munchen.  
Luftschiffahrt-Verein Munster fur Munster und das Munsterland (E. V.) N. W., Munster i. W, Klosterstr. 31-32.  
Magdeburger V. f. L. (E. V.) M, Wetterwarte, Bahnhofstr. 17, Magdeburg.  
Mannheimer V. f. L. "Zahringen" (E. V.) S. W., 7-8 Hansa-Haus, Mannheim.  
Mecklenburgerischer Aero-Club, Kaiser-Wilhelm-Str. 85, II, I, Schwerin i. M.  
Mindener Verein fur Luftfahrt, N. W., Grosser Domhof 1, L, Minden i. W.  
Mitterheinischer V. f. L., S. W., Weisenauer, Str. 15, Mainz.  
Munchener V. f. L. (E. V.) Residentzstr. 27 III, Munchen.  
Niederrheinischer V. f. L. (E. V.) Wilhemstr. 11, Bonn, Wuppertal Sektion, Hauptfeuerwache, Barmen; Essen Sektion, Bachstr. 21, Essen-Ruhr; Bonn Sektion, Wilhelmstr. 11, Bonn.  
Niedersachsischer V. f. L. (E. V.) Hildesheimer Bank, Filiale Gottingen, Gottingen.  
Niederschlesisch-Markischer Verein fur Luftfahrt, Grunberg i. Schl, I.  
Nordmark-Verein fur Motorluftfahrt (E. V.) Dusternbrooker Weg 38, Kiel.  
Obererzgebirgischer V. f. L. (E. V.) Sa, Geschäftsstelle, Schwarzenberg i. S., Erla im Erzgebirge.  
Oberrheinischer V. f. L. (E. V.) S. W., Blauwolkengasse 21, Strassburg i. Els.  
Oberschwabischer V. f. L. (E. V.) S, Promenade 17, Ulm a. D.  
Osnabrucker V. f. L. (E. V.) N. W., Wittekindstr. 4, Osnabruck.  
Ostdeutscher V. f. L. (E. V.) O, Courbierestr. 34, II. Graudenz.  
Ostpreusischer V. f. L. (E. V.) O, Kneiphofische Langgasse 8 I, Konigsberg i. Pr.  
Pfalzischer Luftfahrtverein Speyer, S. W., Speyer a. Rh. I.  
Pommerscher V. f. L. (E. V.) Pasewalk (Stettin) F. 65.  
Posener Luftfahrer-V. (E. V.) O, Posen, Kronprinzenstr, 101a.  
Reichsflugverein (E. V.) Motztrs, 76, Berlin.  
Rheinisch-Westfalische Motorluftschaff-Gesellsch. (E. V.) Bachstr. 21, Essen-Ruhr.  
Saarbrucker Verein fur Luftfahrt, S. W. Saarbrucken, I.

Sachsisch-Thuringischer V. f. L. Belvedere-Allee 5, Weimar; Halle a. S. Sektion (E. V.) Halle a. Muhlweg 10 und Poststr. 6; Thuringische Sektion, Staaten; Belvederealle, 5, Weimar.  
Schlesischer Aero-Club (E. V.) O, Schweidnitzerstr. 16-18 Breslau.  
Schlesischer V. f. L. (E. V.) O, Schweidnitzerstr. 16-18 Breslau.  
Schleswig-Holstein. Flieger-Club, N. W., Niemannsweg 81b, Kiel.  
Seeoffizier-Luftclub (S.L.C.W.) N. W., Peterstr. 80 II, Wilhelmshaven.  
Trierer Club. f. L. (E. V.) W., Nagelstr. 10, Trier.  
V. D. Luftchiff-Industrieller, Kleiststr. 8, III, Berlin, W.  
V. D. Motorfahrzeug-Industrieller, Potsdamerstr. 121b, Berlin, W.  
V. f. Flugwesen in Mannheim, S. W., Lange Rotterstr. 106, I. Mannheim.  
V. f. L. am Bodensee (E. V.) S. W., Zummsteinstr. 11, Schwedenchanze 3a, Konstanz.  
V. f. L. Darmstadt, S. W., Darmstadt, I.  
V. f. L. Gieben, S. W., Seltersweg 56, I., Gieben.  
V. f. L. Kolmar (Posen), (E. V.) O. Provinzialbank, Kommanditgesellschaft a. A., Kolmar i. Pos.  
V. f. L. Limbach (Sa, u. Umgegend) (E. V.) Postr. 5, Limbach (Sachsen).  
V. f. L. in Mainz (E. V.) S. W., Grosse Bleiche 48, Mainz.  
V. f. L. in Worms, S. W., Worms, I.  
V. f. L. und Flugtechnik Nurnberg-Furth, Klaragasse 2 I, Nurnberg.  
V. f. L. in Weimar (E. V.) Erfurter Str. 9, Weimar.  
Vogtlandischer V. f. L. (E. V.) Sa, Plauen i. V, Furstenstr. 89.  
Westfalisch-Lippischer Luftfahrverein (E. V.) N. W., Kavalleriestr, Petri, Bielefeld.  
Westfalisch-Markischer Luftfahrer-Verein, Herne, I.  
Westpreussischer V. f. L. (E. V.) O., Dr. Waldmann, Abte-inng Schiffbau, Technische Hochschule, Danzig-Langfuhr.  
Wissenschaftliche Gesellschaft fur Flugtechnik, Nollendorfplatz 3, Berlin W. 30.  
Wurttembergischer Flugsport-Club, S. Hegelstr. 4b, Stuttgart.  
Wurtembergischer V. f. L. (E. V.) S. am Salzmannsweg 21, Stuttgart.  
Zwickauer V. f. L. (E. V.) Sa, Hauptmarkt 20, Zwickau i. S.

## GERMAN MILITARY AVIATION.

### Army General.

The new Army law provides £400,000 (80 million marks) for Army aviation (including dirigibles), in addition to a considerable share of the £4,000,000 which is being spread over a period of five years.

The Army aerial force will be commanded by 2 inspector generals. The aviation force is put at 4 batallions.

*Headquarters:* Berlin. *Stations:* Aachen, Allenstein, Cologne, Darmstadt, Doebritz, Freiburg, Graudenz, Hannover, Insterburg, Jüterbog, Koenigsberg, Metz, Posen, Strassburg, Zeithain.

The scheme will be complete by the end of the year.

## Army Flying Schools.

Diedenhofen.

Doeberitz.

Metz.

Oberwiesefeld bei München (Bavarian).

Saarburg.

Sperenberg bei Jüterbog.

## Army Aeroplanes.

At the end of 1912 the aeroplane force was as follows:—

Bought in 1911:

**10 monoplanes** (2 *Grade*, 1 *Schultze*, 5 *Rumpler*).

**25 biplanes** (3 *Albatross*, 22 *Farman* type.)

Bought in 1912:

**91 monoplanes** (20 *Bristol*, 1 *Dorner*, 2 *Etrich Taube*, 2 *Grade*, 6 *Harlan*, 20 *Mars*, 40 *Rumpler Taube*).

**144 biplanes** (50 *Albatros*, 12 *Aviatik*, 30 *Euler*, 10 *Otto*, 2 *L.V.G.*, 10 *Mars*, 6 *Wrights*).

Making a total of **270** of which number about 200 were war-effectives.

For **1913** there are **200** new aeroplanes building or provided for.

Under the new regulations, military machines must comply with the following conditions:—

1. Must be of entirely German manufacture, with ample and comfortable seating accommodation for pilot and passenger.
2. Design must permit of fitting bomb droppers and photographic apparatus.
3. Speed capabilities must not be less than 90 kilometres (56 m.p.h.)
4. Dimensions must not exceed 49 feet span (14.50 m.), 39 feet long (12 m.), 13 feet high (3.50 m.), and the motor not more than 100 h.p.
5. Minimum endurance, 4 hours.

## Army Aviators.

Ackermann, Lt. K.

Albrecht, Ob-Lt. K.

Altrichter, Lt. K.

v. Apell, Lt. K.

Barends, Lt.

von Beaulieu, Ob-Lt. W.

Berlin, Ob-Lt. E.

Blume, Lt. W.

Boeder, Lt. O.

Braun, Lt.

Busch, Lt. H.

v. Buttler, Lt. W.

Canter, Lt.

Cipa, T.

Coerper, W. Lt.

von Detten, Lt. G.

Demmel, Lt. M. >br/> Dransfield, Lt. E.

Eich, H.

von Eickstedt, Ob-Lt. V.

Erhardt, Ob-Lt. R. (119)

von Falkenhayn, Lt. F. E.

Graf Finck von Finckenstein, Lt. L.

Fisch, Lt. W. (107)

von Freyberg-Eisenberg-Allmendingen, Lt. F. E.

Funck, Lt. W.

Geertz, F. H. (133)

von Gersdorff, Ob-Lt. E.

Geyer, Lt. H.

Goebel, Ob-Lt. W.

Grade, W. H. St. (20)

von Hadeln, Lt. F.

v. Hammacher, Lt. (49)

von Hammerstein Gesmold, Ob-Lt. F.A.

Hantelmann, Ob-Lt. M.

von Helldorf, Ob-Lt.

v. Hiddessen, F. Lt. (47)

Hildebrand, Ob-Lt. F.

Hofer, Ob-Lt. W.

Höpker, Lt. A.

von Jagwitz, Lt. F.

Joly, Lt. A.

Justi, Lt. K.

Kahl, H.

Kastner, Lt. H.

Keim, Lt. J. (127)

Keller, Lt. G.

Koch, Lt. W.

Kohr, Lt. R.

Lauer, Lt. R.  
Lauterbach, Ob-Lt. F.  
von Lichtenfels, Lt. S. (51)  
von Liusingen, Lt. L.  
Ludewig, F. Ob-Lt.  
Meyer, Lt. W. (136)  
von Minkwitz, Lt. H.  
von Mirbach, Lt. K.  
Mudra, Lt. H. (95)  
Neumann, Ob-Lt. H.  
von Obernitz, Ob-Lt. W.  
Oelsner, Lt. W.  
von Oertzen, Ob-Lt. J.  
von Osterroht, Lt. P-H.  
Petri, Ob-Lt. F. (120)  
Pfeifer, Lt. L.  
Pirner, Lt. H. K.  
von Poser und Gross-Nädlitz, Ob-Lt. F.  
Püschel, Ob-Lt. K.  
Rapmund, Lt. M.  
Reiche, Lt. A.  
v. Reichenberg-Wolfskeel, Graf. (93)  
Reinhardt, Lt. S.  
Reuss, Lt. W.  
Ritter, Lt. K. (121)  
Roser, H. H. (83)  
Schäfer, Ob-Lt. L.  
v. Scheele, Lt. A.  
Schlegel, Lt. O.  
Schneider, Lt. H.  
Schreyer, F.  
Schulz, Lt. J.  
Schwartzkopff, Lt. H.  
Serno, Lt. E.  
Sieber, Lt. H.  
Solmitz, F. Lt.  
Sommer, Lt. P.  
Steindorf, H.  
Steger, O. Lt.  
von Stoephasius, Lt. M.  
Striper, Lt. F.  
Suren, Lt. E.  
Suren, Lt. G.  
Suren, Lt. H.

Taeufert, Lt. W.  
v. Tiedemann, Ob-Lt. R. (17)  
von Trotha, Ob-Lt.  
Vogt, Lt.  
v. Wedemeyer, Ob-Lt. E.  
Wendler, Lt. W.  
Weyer, Lt. G.  
Wiegandt, Lt. W.  
Wilberg, Ob-Lt. H. (26)  
Wildt, Lt. K. (43)  
Wirth, Ob-Lt. W. (92)  
Wulff, Lt. A.  
Zwickau, Lt. K.

### **Navy General.**

The 1913 expenditure on naval aviation (including dirigibles) is £250,000 (50 million marks), plus a portion of the special expenditure.

### **Naval Flying Schools.**

**Holminsel** b. Danzig.  
**Putzig** b. Danzig.

### **Naval Stations.**

**North Sea.**—Cuxhaven (staff to be 5 officers and 192 under officers and men), Emden and Hamburg.

**Baltic.**—Kiel, Putzig and Königsberg.

**General Headquarters.**—Berlin.

Each station will ultimately consist of one dirigible and a number of hydro-aeroplanes.

### **Navy Aeroplanes.**

At the end of 1912 the total effective force was:—

**4 monoplanes** (*Rumpler* hydro.)

**10 biplanes** (4 *Albatros* hydro., 2 *Curtiss* hydro., 4 *Euler*).

Total 14

The *Curtiss* were purchased towards the end of 1911, all the others in 1912.

All are or can be fitted with wireless, range 50 miles.

1913. Others on order, including *Ottos* on floats (*A.G.O.*), of which one was delivered in April.

### **Navy Aviators.**

Bertram, Ob-Lt. (123)  
Coulmann, W.  
Francke, Ob-Lt. C. (142)  
Goltz, Kap-Lt. K.  
von Gorrissen, Lt. (4)  
Hartmann, R. Ob-Lt. (96)  
Hering, Kap-Lt. M.  
Janetzky, Kap-Lt. W.  
Langfield, Ob-Lt. W.  
Prinz Heinrich von Preussen (38)  
Schroeter, Ob-Lt. W.  
Stemmler, B.

### **GERMAN PRIVATE AVIATION.**

To end of March, 1913.

Private Aeroplanes.

At end of March, 1913, the number of private aeroplanes in Germany was about 80, of which most were school, etc., machines.

Abelmann, Carl  
Abramowitch, Wasewolod  
Albers, Wilhelm  
Alig, Ernst.  
Arntzen, Orla, Dr. jur.  
Schirrmeister, Hans  
Badowski, Ludwig  
Baierlein, Anton  
Basser, Gustav  
Beck, Otto  
Becker, Reinhold  
Beese, Frl.  
Behrend, Adolf  
Berliner, Rudolf  
v. Bieber, Harald, Dr. jur.

Birkmaier, August  
Blattmann, Ernst  
Bohlig, Edmund  
Bosenius, Rudolf  
Bossin, Fritz  
Boutard, Charles  
Braselmann, Karl  
Breton, Raymond Arthur  
Brociner, Marco  
Brunnhuber, Simon  
Büchner, Bruno  
Charlett, Willi  
Clauberg, Fritz  
Cremer, Fritz  
Curdts, Carl  
De Waal, Bernard  
Dick, Fritz  
Donnevert, Willy  
Dorner, Hermann  
Dücker, Werner  
Eberhardt, Alfred  
Eckardt, Willy  
Eckelmann, Frank  
Engelhard, Paul  
Erblich, Heinz  
Euler, August  
Evers, Heinrich  
Eyring, Raymund (Dr. Huth)  
Falderbaum, Heinz  
Faller, Artur  
Faller, Otto  
Flégier, Th. v.  
Fokker, Anthony  
Fremery, Hemmann  
Friedrich, Alfred  
Gasser, Hermann  
Geiss, Franz  
Georgi, Johannes  
v. Gorrissen, Ellery  
Grade, Hans  
Griebel, Otto, Leutnant a D.  
Grulich, Karl  
Grünberg, Arthur  
Haas, Heinrich

Hansen, Hans  
Hanuschke, Bruno  
Hartmann, Alfred  
Hasenkamp, Emil  
Häusler, Hugo  
Heim, Oskar  
Heirler, Paul  
Hennig, Alfred  
Hess, Robert  
Heydenreich, Fritz  
Hild, Luc.  
Hintner, Cornelius  
Hirrlinger, Albert  
Hirth, Helmuth  
Hoff, Wilhelm  
Hoffmann, Siegfr.  
Hoos, Josef, Dr. jur.  
Hormel, Walter  
Horn, Albin  
Hoesli, Gordian  
Ingold, Karl  
Jablonski, Bruno  
Jahnnow, Reinhold, Leutn. d. Landw.  
Jänisch, M.  
Jeannin, Emil  
Kahnt, Oswald  
Kammerer, K. F. Ludwig  
Kaniss, Gustav  
Kanitz, Willy  
Karsten, Otto  
Kaspar, Referendar  
Katzian, Artemy  
Keidel, Fridolin  
Kern, Willy  
Kiepert, Rudolf  
Kleinle, Josef  
Kober, Theodor  
Köhler, Erich  
Kohnert, Herbert  
König, Benno  
König, Martin  
Krastel, Heinz, Reimar  
Krieg, Friedrich  
Krieger, Karl

Krüger, Leutnant a. D.  
Krüger, Arthur  
Krumstiek, Wilhelm  
Kühne, Ernst Herbert  
Kunze, Ernst  
Kurtscheid, Nicolaus  
Ladewig, Heinz.  
Ladewig, Herbert, Leutnant, Inf.-Regt.  
Lagler, Fräulein Bozena  
Laitsch, Felix  
Laemmlin, Charles  
Lange, Paul  
Langer, Bruno  
Lecomte, Ingenieur  
Lenk, Willy  
Lichte, Carl  
Lie, Christian  
Lindpaintner, Otto E.  
Linnekogel, Otto  
Lissauer, Walter  
Lochner, Erich  
Loew, Karl  
Lübbe, Fluglehrer  
Manhardt, Alfred Willy  
Mente, Willy, Oberleutnant a. D.  
Meybaum, Theodor  
Michaelis, G. A.  
Mischewsky, Bernard  
Mohns, Karl  
Möhring, Charlotte  
v. Mossner, Robert, Oberleutnant a. D.  
Mügge, Wilhelm, Kapitän d. Handelsmarine  
Müller, B. C. Oscar  
Müller, Friedrich  
Müller, Karl  
Müller, Kurt  
Munkelt, Kurt  
Mürau, Georg  
Netzow, Georg  
Niemela, Edmund, Leutnant a. D.  
Noelle, Max  
Oelerich, Heinrick  
Oster, Franz  
Ottenbacher, Ernst

Otto, Gustav  
Paul, Alfred  
Pentz, Hermann  
Pietschker, Alfred  
Placzikowski, Udo  
von Platen, Horst  
Plochmann, Ernst  
Pokristev, Penn, Oberleutnant  
Poulain, Gabriel  
Reeb, Alfred  
Reichhardt, Otto  
Rentzel, Adolf  
Rode, Franz  
de le Roi, Wolfram  
Roempler, Oskar  
Rosenstein, Willy  
Roessler, Fritz  
Rost, Gottlieb  
v. Rottenburg, Otto  
Roever, Hans  
Rupp, Albert  
Rütgers, August  
Schadt, Karl  
Schäfer, Otto  
Schakowskoy, Fürstin Eugenie  
Schall, Karl  
Schauenburg, Theodor  
Schendel, Georg  
Scherff, Mauricio  
Schiedeck, Hermann  
v. Schimpf, Ernst, Dr. jur  
Schirrmeister, Hans  
Schlatter, Joseph  
Schlegel, Ernst  
Schlüter, Fritz  
Schmidt, Erich  
Schmidt, Richard  
Schmigulski, Hans  
Schöner, Georg  
Schultze, Gustav  
Schüpphaus, Heinrich Ernst  
Schwandt, Paul  
Schwarz, Erwin  
Sedlmayer, Gerhard

Senge, Paul  
Seydler, Frank  
Siewert, Lotherm  
Steffen, Bruno  
Steinbeck, Hans  
Stiefvater, Otto  
Stöffler, Victor  
Stoldt  
Stoephasius, Curt von  
Strack, Karl  
Strack, Peter  
Stüber, Joachim, Leutnant d. R.  
Suvelack, Josef  
Thelen, Robert  
Thiele, Erich  
Toepfer, Otto  
Trautwein, Max  
Treitschke, Friedrich  
Tybelski, Franz  
Tweer, Gustav  
Vollmüller, Hans  
Wechsler, Rubin  
Weickert, Julius Artur  
Weinaug, Ernst  
Werntgen, Bruno  
Wertheim, Paul  
Weyl, Richard  
Wiencziers, Eugen  
Wieting, Werner  
Wirtz, Reiner  
Witte, Gustav  
Wittenstein, Oskar, Dr.  
Witterstätter, E. W.  
Wolter, Richard  
von Zastrow, Alexanderm

Note.—Abramowitch was a Russian by birth (killed April, 1913).

The following German aviators have been killed:—

**1896.**

Lilienthal

**1910.**

Haas, Lieut.

Mente, Lieut.  
Plochmann  
Robl, Thaddeus

**1911.**

Bockmüller  
Bournique ("Pierre Marie")  
Choendel  
Dax  
Englehardt, Kapt.  
Eyring, R.  
Frh. v. Freytag-Loringhoven  
Laemmlin  
Lecomte  
Neumann, Lieut.  
Reeb  
Pietschker  
Schendel, G.  
Stein, Lieut.  
Tachs  
Voss

**1912.**

Alig  
Altrichter  
Beissbarth  
Berger  
Birkymayer  
Buchstätter  
v. Falkenhayn  
Frh. v. Schlichting  
Fischer  
Hamburger  
Hofer  
Hösli  
Junghans  
König  
Kugler  
Lachmann  
Lang  
Libau  
Meyer  
Preusser  
Pochmeyer  
Rheinle

Rost  
Schmidt  
Schmigulski  
Stille  
Werntgen  
Witte

**1913.**

Held  
Schlegel

# GERMAN AEROPLANES.

## A

### ALBATROS.

Albatroswerke G.m.b. H, Flugzeugfabr. u. Fliegerschule, Johannisthal bei Berlin. Established 1910. One of the largest constructors in Germany. Capacity: 150 machines a year.

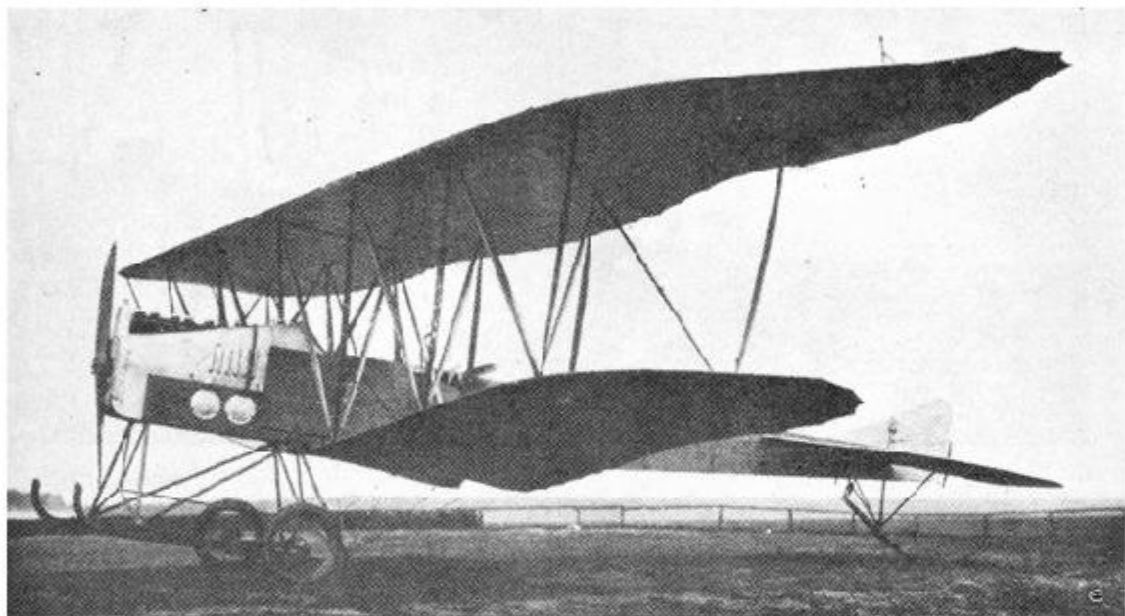

		1911-12. 2-seat tractor biplane.	Military tractor biplane.	1912. Military tractor	1912-13. Hydro.	Mono.
Length	feet (m.)	35-1/2 (10.70)	34-1/2 (10.5)	42-1/2 (12.8)	...	...
Span	feet (m.)	43-2/3 (13.30)	52-1/2 (16)	65-3/4 (20)	...	...
Area	sq. feet (m <sup>2</sup> .)	430 (40)	576 (54)	624 (58.5)	...	...
Weight	total lbs. (kgs.)	1058 (480)	1543 (700)	1874 (850)	...	...
	useful lbs. (kgs.)	661 (300)	...	...	...	...
Motor	h.p.	100 Argus	90 Mercedes or 100 Argus	120 N.A.G. or Aust. Daimler	...	...
Speed	max. m.p.h. (km.)	56 (90)	59 (95)	46 (75)	...	...
	min. m.p.h. (km.)	...	...	...	...	...
Endurance	hrs.	6	6	7-5	...	...
Number built during 1912		about 40	70	30	4	2

Remarks.—In all the upper plane is slightly staggered. In all the control is duplicated.



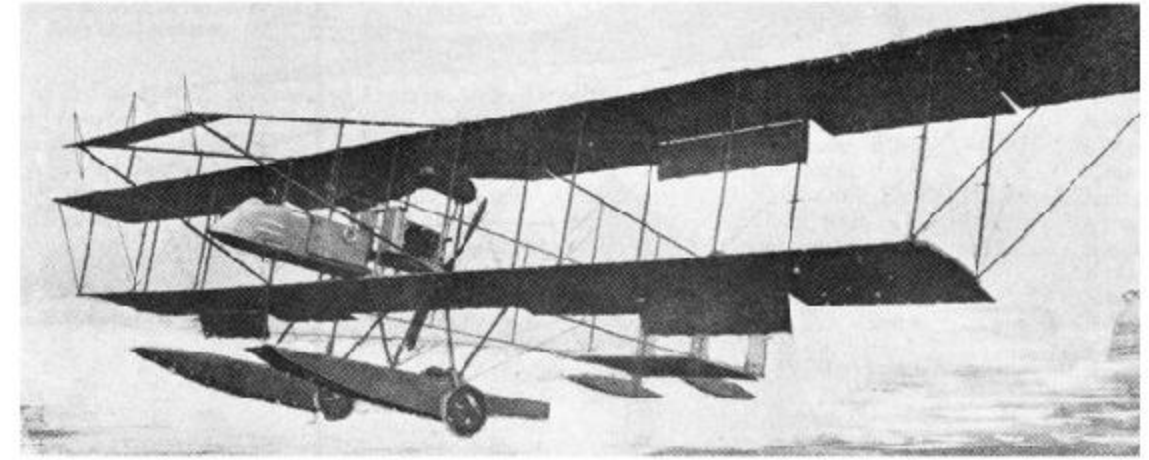
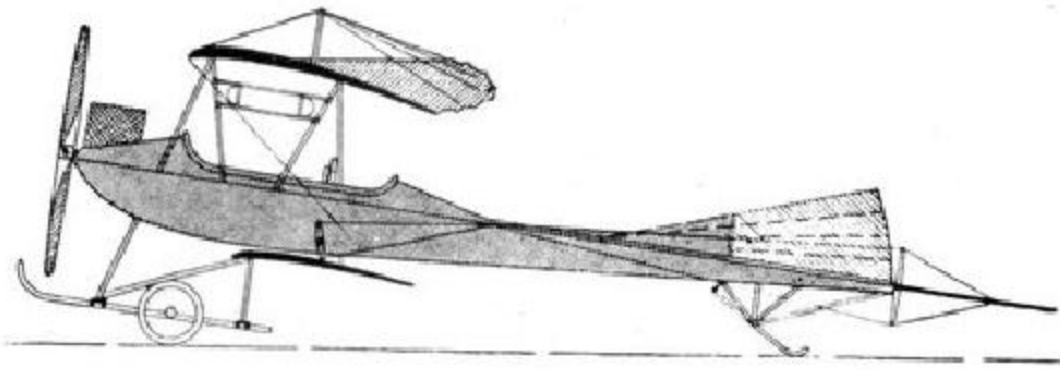

Albatros. Military hydro-biplane.

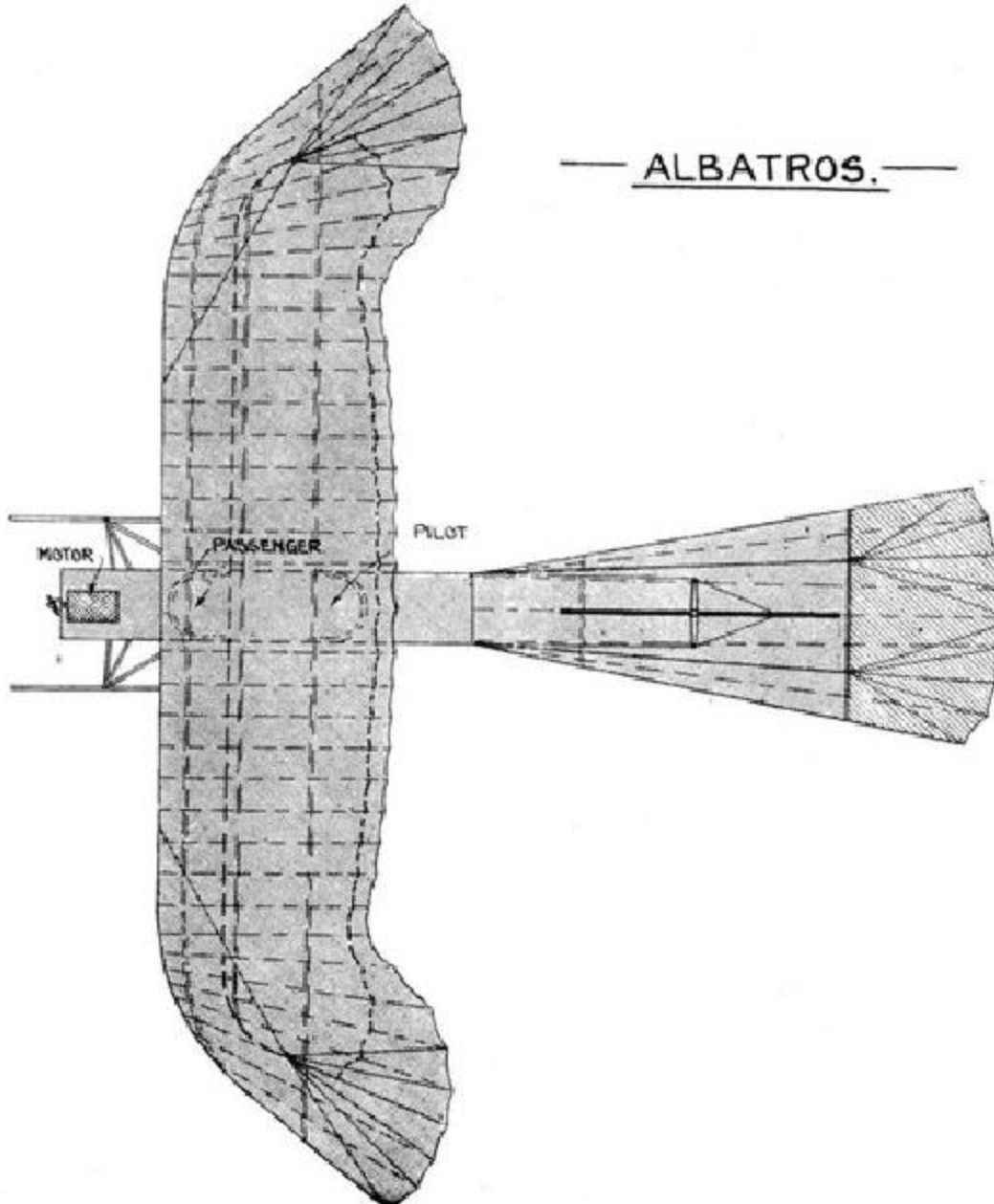

— ALBATROS. —

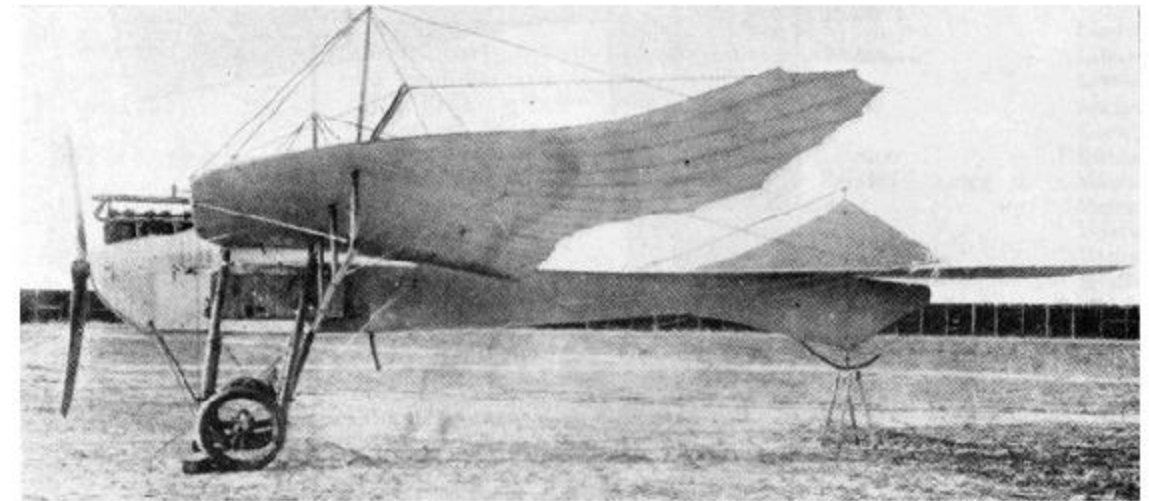

Albatros. Monoplane.

### AVIATIK.

Automobil & Aviatik A.G., Mülhausen i.E. Established 1910. Capacity: 100 a year.

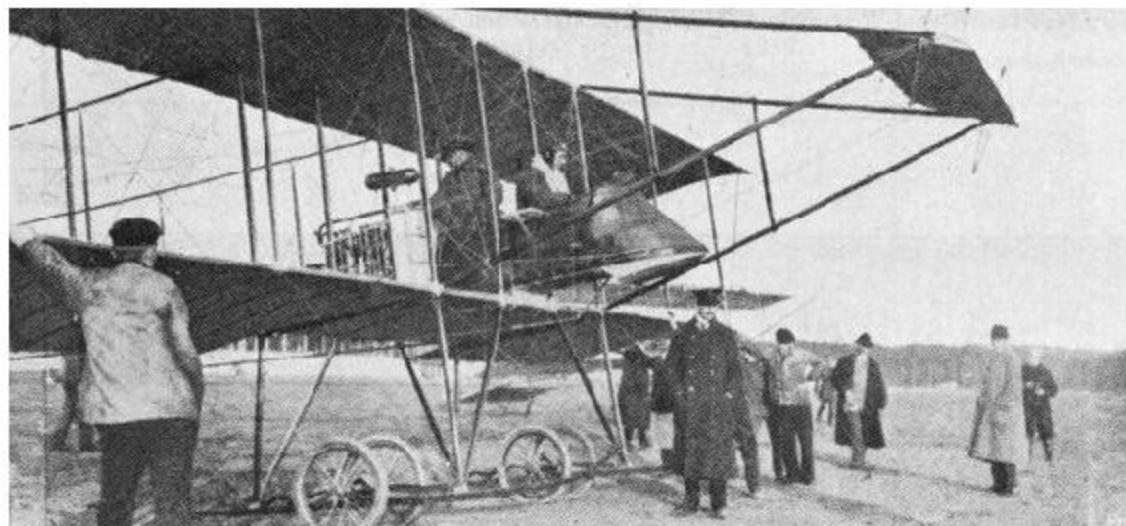

1912 biplane.

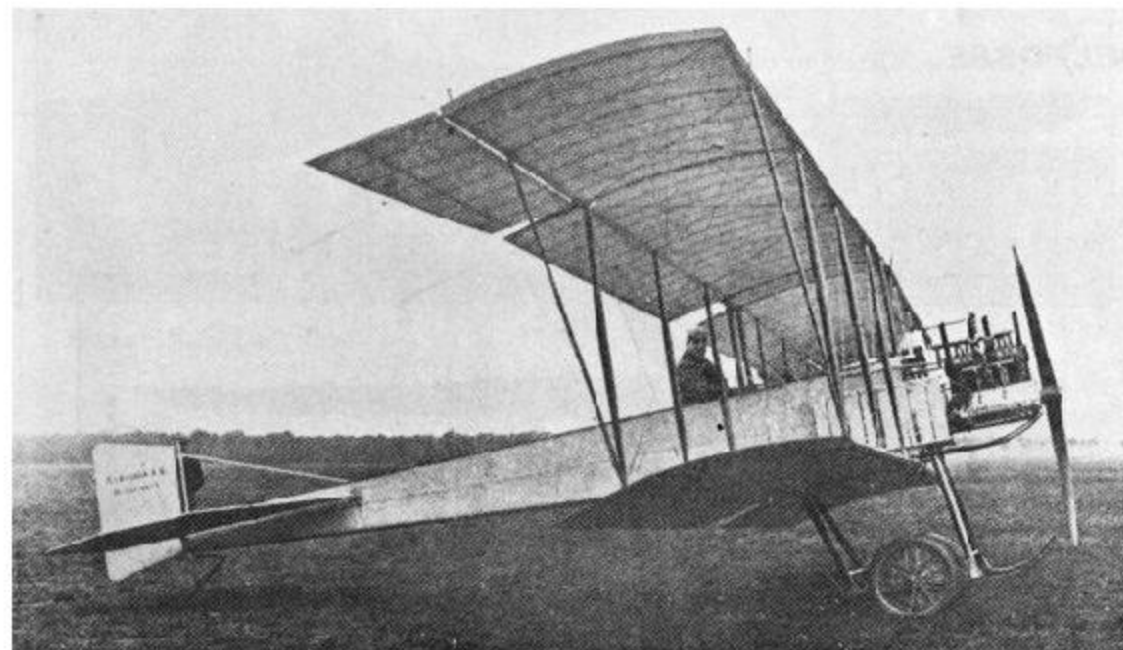

1913 tractor-biplane (racer).

		1912. Monoplane.	1912. Biplane.	1913. Racing biplane.	1912-13. Hydro- biplane.
Length	feet (m.)	26-1/2 (8)	36 (11)	29-1/2 (9)	36 (11)
Span	feet (m.)	39 (11.80)	52-1/2 (16)	52-1/2 (16)	62-1/3 (19)
Area	sq. feet (m <sup>2</sup> .)	258 (.24)	517 (48)	517 (48)	597 (56)
Weight	total lbs. (kgs.)	1146 (520)	1323 (600)	1234 (560)	1653 (750)
	useful lbs. (kgs.)	661 (300)	882 (400)	882 (400)	661 (300)
Motor	h.p.	100 Argus	100 Argus	100 Argus	100 Argus
Speed	max. m.p.h. (km.)	68-1/2 (110)	56 (90)	62 (100)	52 (80)
	min. m.p.h. (km.)	...	...	...	...
Endurance	hrs.	5	6-8	7-8	4-5
Number built during 1912		6	20	4	3

Remarks.—The monoplanes are constructed under *Hanriot* license.



Monoplane.

**D**

**DELFOSE.**

Ceased to construct.



Dorner

### DORNER III. Monoplane.

**Length.**—34½ feet (10.50 m.) **Span.**—39-1/3 feet (12 m.) **Surface.**—280 sq. feet (126 m<sup>2</sup>.)  
**Weight.**—882 lbs. (400 kgs.)

Type II: **Length.**—32¾ feet (10 m.) **Span.**—38 feet (11.60 m.) **Surface.**—268½ sq. feet (25 m<sup>2</sup>.) **Weight.**—661 lbs. (300 kgs.) See *Flugsport*, No. 5, 1911.

## E

### ETRICH.

Etrich Fliegerwerke, G.m.b. H, Dittersbach b. Liebau (Schlesien). Capacity: 50 a year.

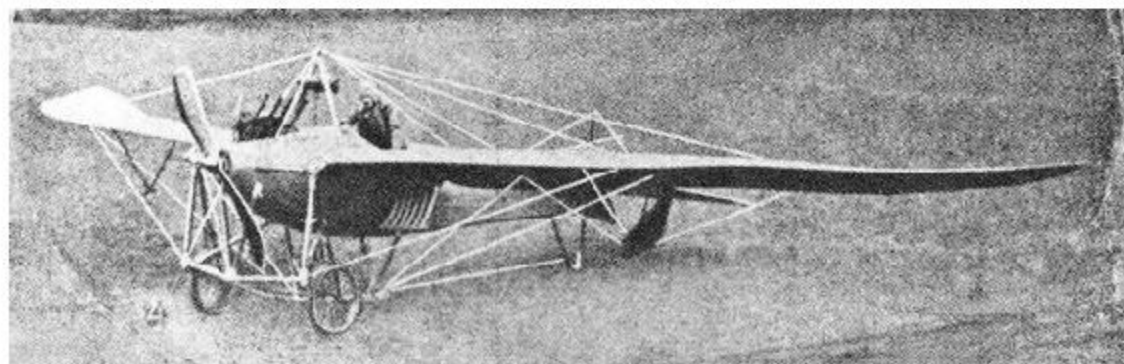

		1913. Etrich (original) <i>Taube</i> . monoplane.
Length	feet (m.)	31 (9.5)
Span	feet (m.)	47-1/2 (14.4)
Area	sq. feet (m <sup>2</sup> .)	301 (28)
Weight	Total lbs. (kgs.)	1323 (600)
	Useful lbs. (kgs.)	...
Motor	h.p.	100 Mercedes or Argus
Speed	max. m.p.h. (km.)	71 to 75 (115 to 120)
	min. m.p.h. (km.)	...
Endurance	hrs.	6

Remarks.—

### EULER.

August Euler, Frankfurt a.M. In 1908 Euler secured *Voisin* rights for Germany. In 1910 he took out a patent for a design of his own. In the summer of 1911 he built a successful monoplane, in the autumn of the same year a triplane. Existing models are as follows:—

		1912. Triplane.	1912. Monoplane.	Military biplane.
Length	feet (m.)	23 (7)		
Span	feet (m.)	23 (7)		
Area	sq. feet (m <sup>2</sup> .)	...		
Weight	total lbs. (kgs.)	...	no data	no data
	useful lbs. (kgs.)	...		
Motor	h.p.	Gnome		
Speed	max. m.p.h. (km.)	56 (90)		
	min. m.p.h. (km.)	...		
Endurance	hrs.	3-4		
Number built during 1912		about 70	of various types	

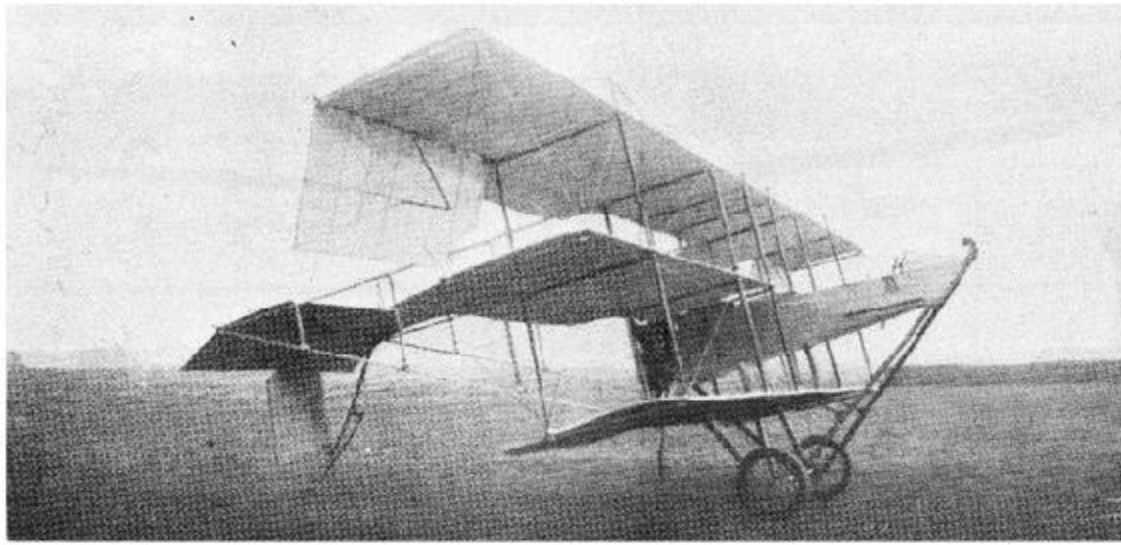

Euler. Triplane.



Euler. Military biplane.



Euler. Monoplane, 1912.

## F

### FOKKER.

Monoplanes. Fokker-Aeroplanbau, G. m. b. H., 18 Parkstrasse, Johannisthal bei Berlin. Capacity: 40.

		1912. A.	1912. B.	1912-13. A.	1912-13. B.	1912-13. C.	1913. Hydro- aeroplane.
Length	feet (m.)	26-1/4 (8)	26-3/4 (8.25)	29-1/2 (9)	29-1/2 (9)	29-1/2 (9)	31 (9.50)
Span	feet (m.)	37-3/4 (11.50)	39-1/3 (12)	42-3/4 (13.20)	42-3/4 (13.20)	42-3/4 (13.20)	52-1/2 (16.20)
Area	sq. feet (m <sup>2</sup> .)	226 (21)	242 (22.50)	280 (26)	280 (26)	280 (26)	...
Weight	total lbs. (kgs.)	838 (380)	1036 (470)	970 (440)	1146 (520)	1190 (540)	...
	useful lbs. (kgs.)	...	...	...	...	...	...
Motor	h.p.	70 Argus	100 Argus	70 Argus or Dixi	100 Argus	70 Renault	100 Renault or Mercedes

Speed	max. m.p.h. (km.)	56 (90)	68 (108)	52 (83)	60 (96)	53 (85)	59 (95)
	min. m.p.h. (km.)	...	...	43 (70)	...	...	...
Endurance	hrs.	4-6	4-6	5-8	5-8	4-6	4
Number built during 1912		3	2	6	5	2	...

Remarks.—The *Fokker* is a machine of Dutch origin. (See Dutch).

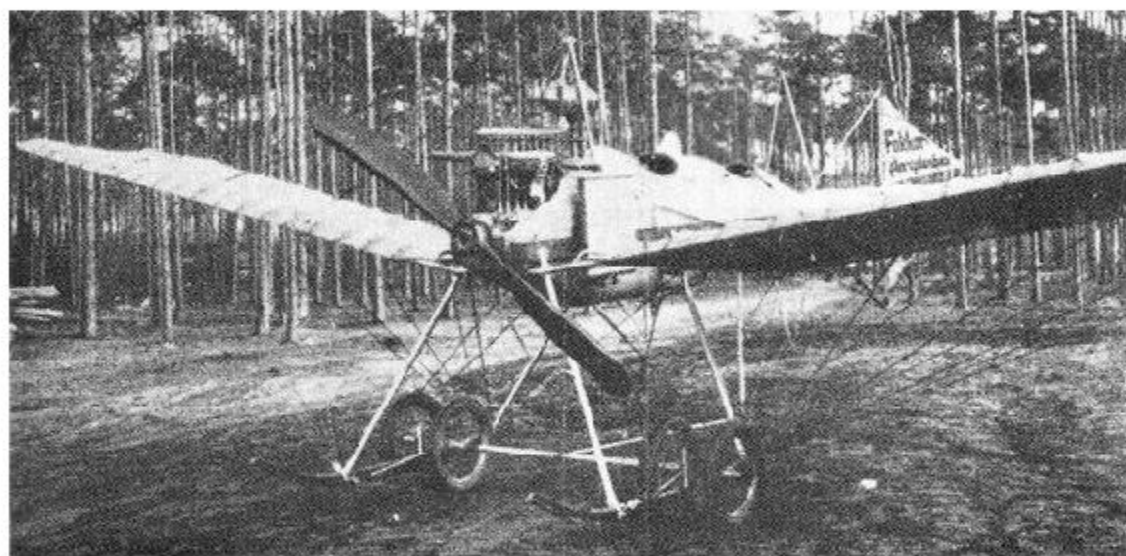

1912-13 model.



Hydro.

## FOHN.

This firm ceased to exist January, 1913.

## G

## GRADE.

Hans Grade Fliegerwerke, Bork, Post Bruck (Mark). Founded 1910 by H. Grade, who was the first man in Germany to fly with a German machine. During 1911 *Grades* had a considerable vogue, but since then have not been prominent.

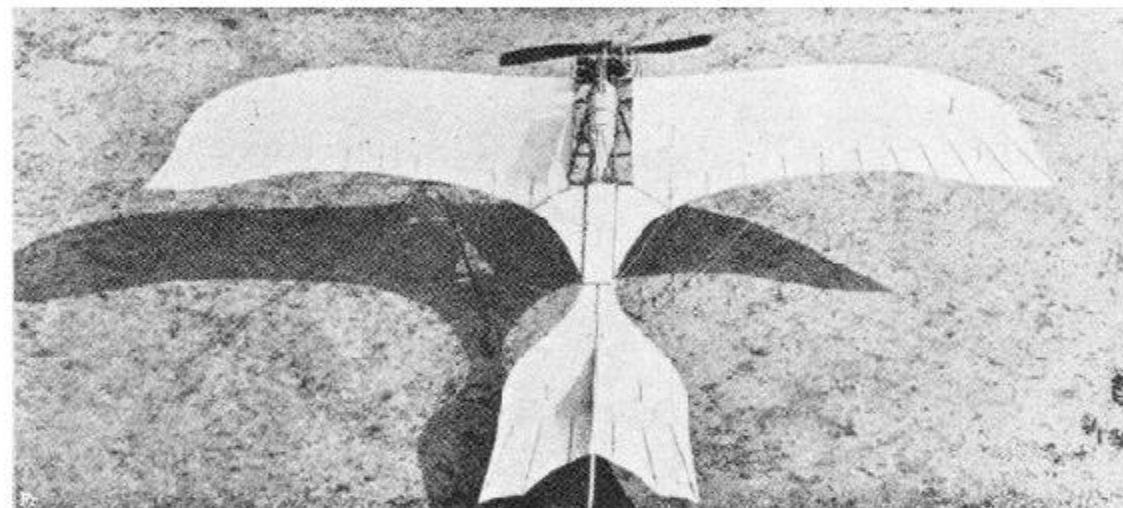

1912 racer.

Model and date.	Racer, 1911. C.	Racer, 1912. D.	Racer, 1912. E.
Length feet (m.)	33 (10)	21 (6.50)	26-1/4 (8)
Span feet (m.)	39-1/4 (12)	34-1/2 (10.50)	41 (12.50)
Area sq. feet (m <sup>2</sup> .)	480 (45)	240 (22)	360 (33)
Weight machine, lbs. (kgs.)	375 (170)	408 (185)	595 (270)
useful lbs. (kgs.)	... ..	... ..	... ..
Motor h.p.	various	... ..	... ..
Speed m.p.h. (km.)	56 (90)	71 (115)	71 (115)
Number built during 1912	?	1 or 2	?

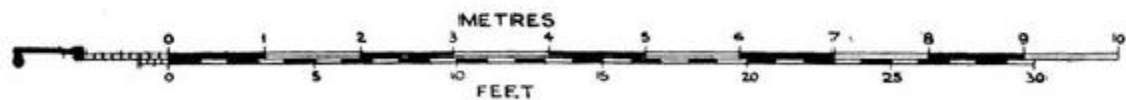
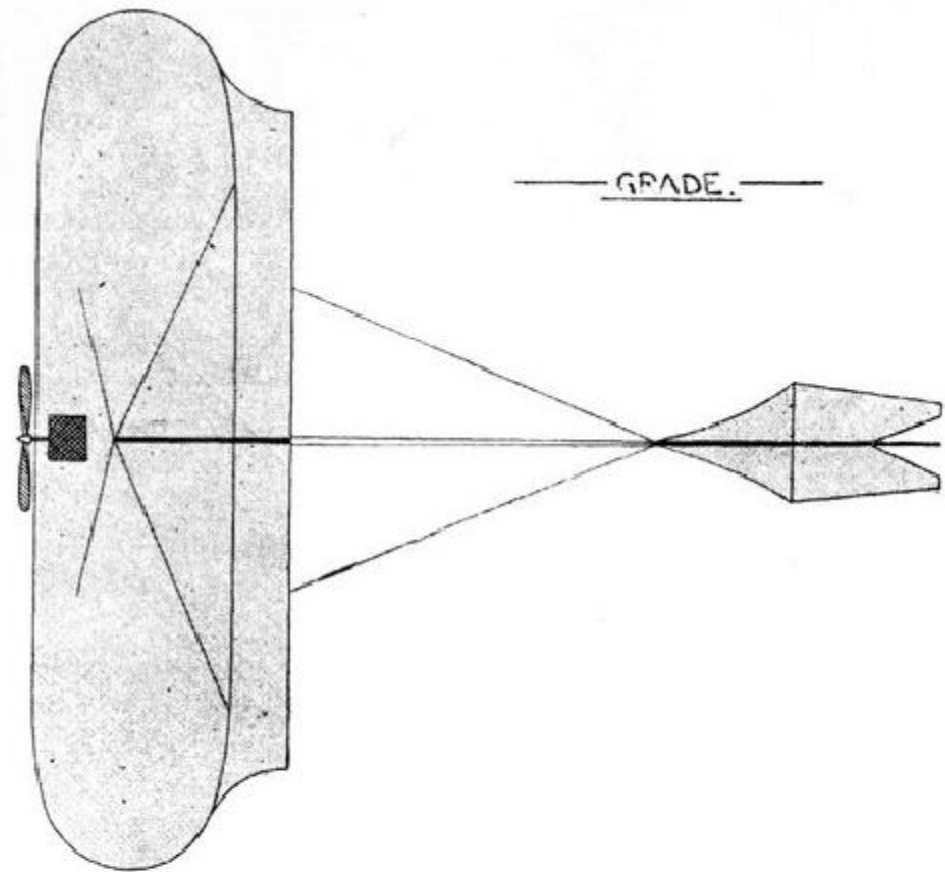
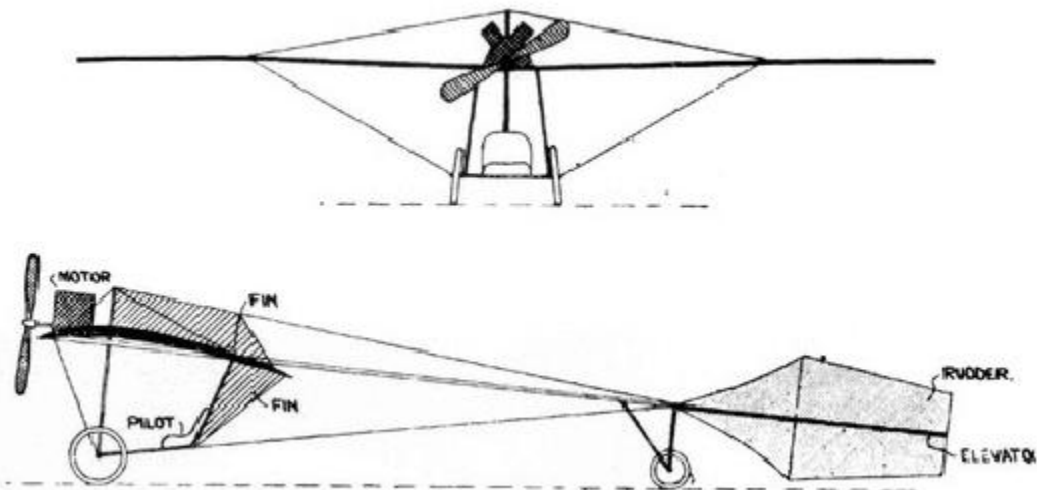

GRADE. Uniform Aeroplane Scale

## GOEDECKER.

J. Goedecker, Flugmaschinen-Werke, Niederwalluf a. Rh. Flying School: Flugplatz Grosser Sand bei Mainz.

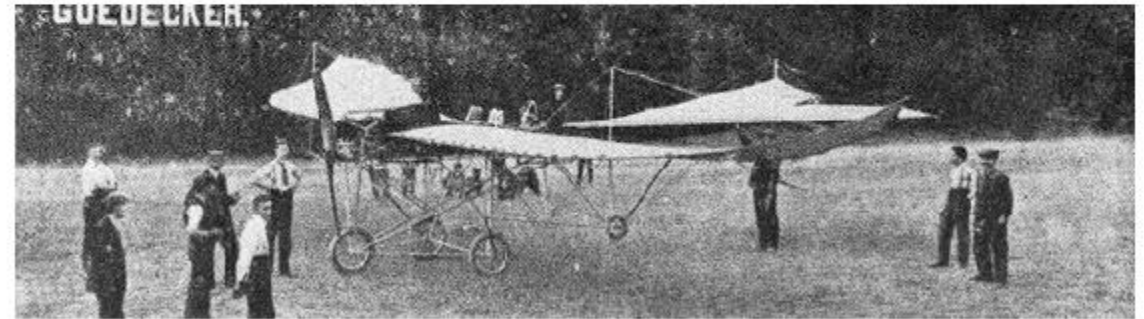

GOEDECKER.

		1912. Monoplane "Sturmvogel."	1911. Monoplane "Sturmvogel."
Length	feet (m.)	32-3/4 (10)	29-1/2 (9)
Span	feet (m.)	47-3/4 (14.5)	47-3/4 (14.5)
Area	sq. feet (m <sup>2</sup> .)	387 (36)	...
Weight	total lbs. (kgs.)	992 (459)	827 (375)
	useful lbs. (kgs.)	...	...
Motor	h.p.	100 Dixi	70 Argus
Speed	m.p.h. (km.)	56 (90)	...
Number built during 1912		8	2

## H

## HANSA-TAUBE.

Heinrich Heitmann, Aviatik und Konstruktions Werkstätten, Altona.

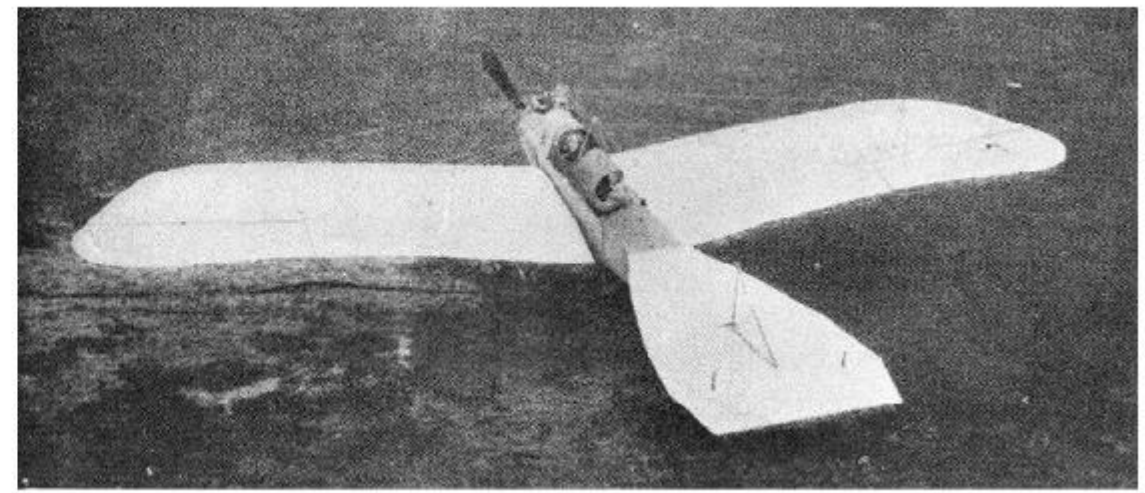
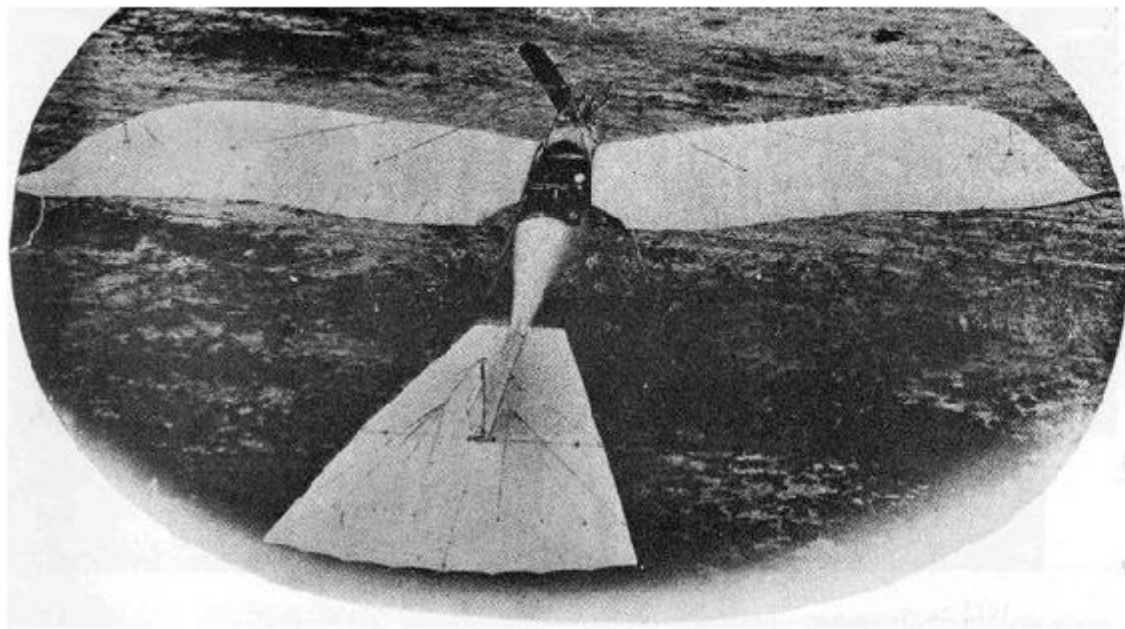

		1912. Monoplane.	1913. Monoplane.
Length	feet (m.)	24-3/4 (7.5)	24-3/4 (7.5)
Span	feet (m.)	36-3/4 (11.2)	36-3/4 (11.2)
Area	sq. feet (m <sup>2</sup> .)	237 (22)	237 (22)
Weight	total lbs. (kgs.)	617 (280)	573 (260)
	useful lbs. (kgs.)	...	...
Motor	h.p.	75 or 100 Argus	100 Argus
Speed	m.p.h. (km.)	56 to 62 (95 to 100)	62 (100)
Number built during 1912		2	2

Remarks. —

### HARLAN.

Harlan Werke, G. m. b. H., 21 Moltkestrasse, Johannisthal bei Berlin. Established 1909, turned into present Company, 1911. Output capacity about 50 machines a year.

		1912. Military monoplane.	1912-13. Military monoplane.
Length	feet (m.)	26-1/4 (8)	30 (9.10)
Span	feet (m.)	39-1/3 (12)	45-1/2 (13.80)
Area	sq. feet (m <sup>2</sup> .)	312 (29)	312 (29)
Weight	total lbs. (kgs.)	...	1984 (900)
	useful lbs. (kgs.)	...	1323 (600)
Motor	h.p.	100 Argus or Mercedes	100 Argus
Speed	m.p.h. (km.)	69 (110)	69 (110)
Endurance	hrs.	7-8	7-8
Number built during 1912		20	15

### HANUSCHKE.

Bruno Hanuschke, Flugzeugbau, Johannisthal b. Berlin. Capacity: small.

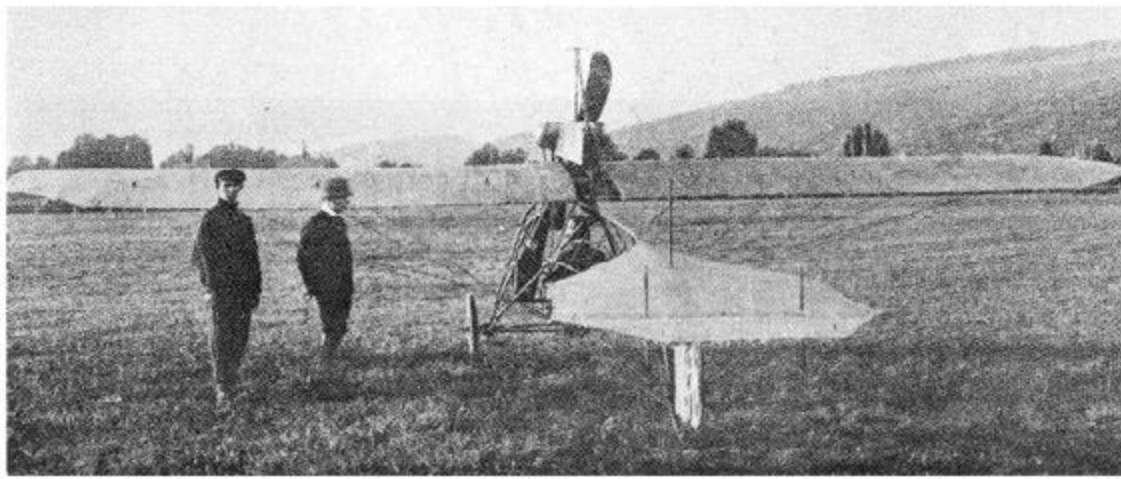

		1912. "Typ populaire"	1913. Typ II.
Length	feet (m.)	24-3/4 (7.50)	21 (6.50)
Span	feet (m.)	27 (8.25)	26-1/4 (8)
Area	sq. feet (m <sup>2</sup> .)	183 (17)	172 (16)
Weight	total lbs. (kgs.)	716 (325)	1102 (500)
	useful lbs. (kgs.)	385 (175)	600 (275)
Motor	h.p.	35 Anzani	50 Gnome
Speed	m.p.h. (km.)	56 (90)	62 (100)
Endurance	hrs.	2	2
Number built during 1912		2	2

Remarks.—

## J

### JATHO.

Jatho Flugzeugwerke, G. m. b. H., Stader Chaussee 32, Hannover. Karl Jatho built his first aeroplane in 1899, and has produced machines at intervals ever since. Capacity: small.

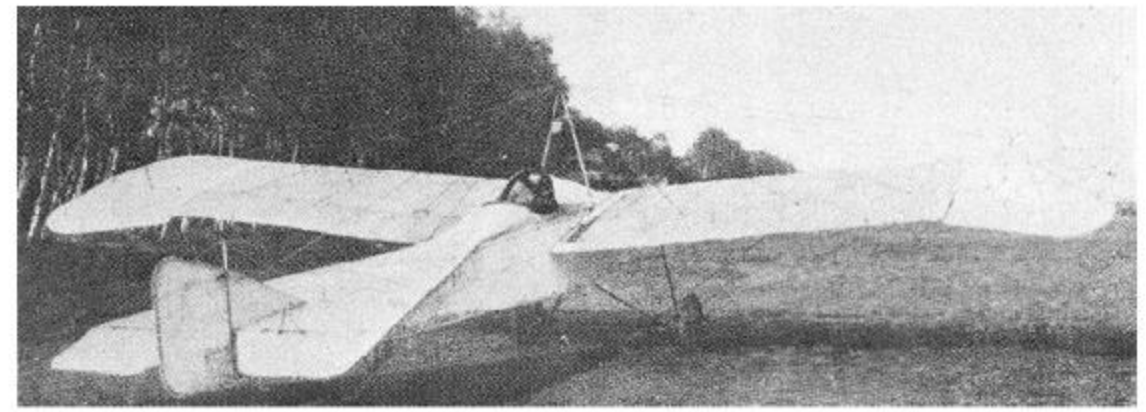

		1913.
Length	feet (m.)	29-1/2 (9)
Span	feet (m.)	49-1/4 (15)
Area	sq. feet (m <sup>2</sup> .)	345 (32)
Weight	total lbs. (kgs.)	2116 (960)
	useful lbs. (kgs.)	992 (450)
Motor	h.p.	100 N.A.G.
Speed	m.p.h. (km.)	75 (120)
Endurance	hrs.	3
Number built during 1912		2

Remarks.—

### JEANNIN.

Emile Jeannin, Flugzeugbau, G. m. b. H., Stahltauben & Renneindecker Fabrik, Johannisthal b. Berlin. Capacity: small.



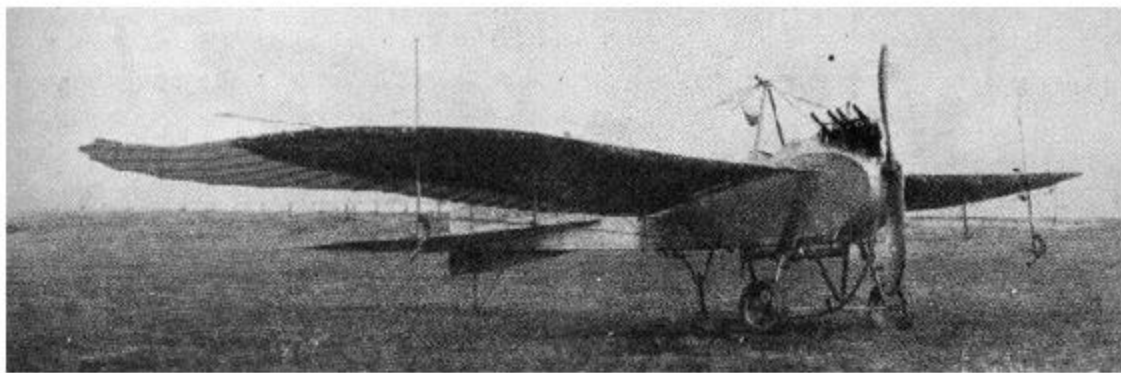

1912 "Taube."

	1912. "Taube" monoplane.	1913. Racing monoplane.
Length	feet (m.) 29-1/2 (9)	...
Span	feet (m.) 42-3/4 (13)	...
Area	sq. feet (m <sup>2</sup> .) ...	...
Weight	total lbs. (kgs.) ...	...
	useful lbs. (kgs.) ...	...
Motor	h.p. 100-150 Argus	150 Argus
Speed	m.p.h. (km.) 68 (110)	87 (140)
Endurance	hrs. 5-8	4-7
Number built during 1912	2	3

Remarks.—The 1913 was building only in March.

## K

### KAHNT.

Oswald Kahnt, Flugzeugbau, Leipzig. Capacity: small.



		K. F. 1913. "Falke."
Length	feet (m.)	27-3/4 (8.50)
Span	feet (m.)	42-3/4 (13)
Area	sq. feet (m <sup>2</sup> .)	291 (27)
Weight	total lbs. (kgs.)	...
	useful lbs. (kgs.)	...
Motor	h.p.	50-70
Speed	m.p.h. (km.)	62 (100)
Number built during 1912		new firm

### KONDOR.

Kondor Flugzeugwerke G. m. b. H., Essen, Ruhr. Fabrik auf dem Flugplatz. Rotthausen. Capacity: 30 or so a year.

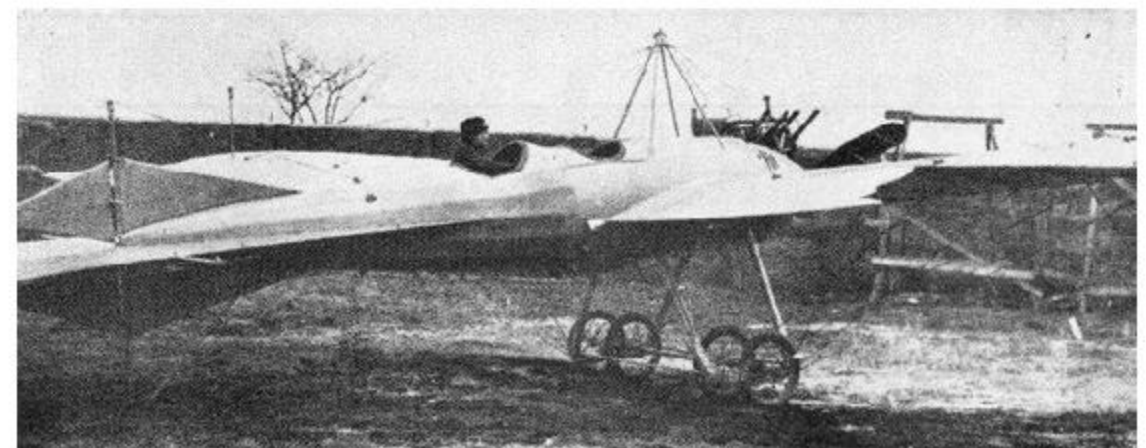

1913 model. (1912 same appearance.)

		1912.	1913.
Length	feet (m.)	33-3/4 (10.30)	27 (8.20)
Span	feet (m.)	48-3/4 (14.80)	46 (14)
Area	sq. feet (m <sup>2</sup> .)	258 (24)	280 (26)
Weight	total lbs. (kgs.)	1543 (700)	1328 (600)
	useful lbs. (kgs.)	...	...
Motor	h.p.	100 Argus	100 Argus
Speed	m.p.h. (km.)	65 (105)	70 (112)
Number built during 1912		2	...

*Remarks.*—Both models torpedo body, on 4 skids. Planes dart V form. Constructor: J. Suwelack.

## KÜHLSTEIN.

Kühlstein Wagenbau, Karosseriefabrik, Salzufer 4, Charlottenburg. This old-established motor car firm commenced to build aeroplanes in 1911. Capacity: 20 a year.

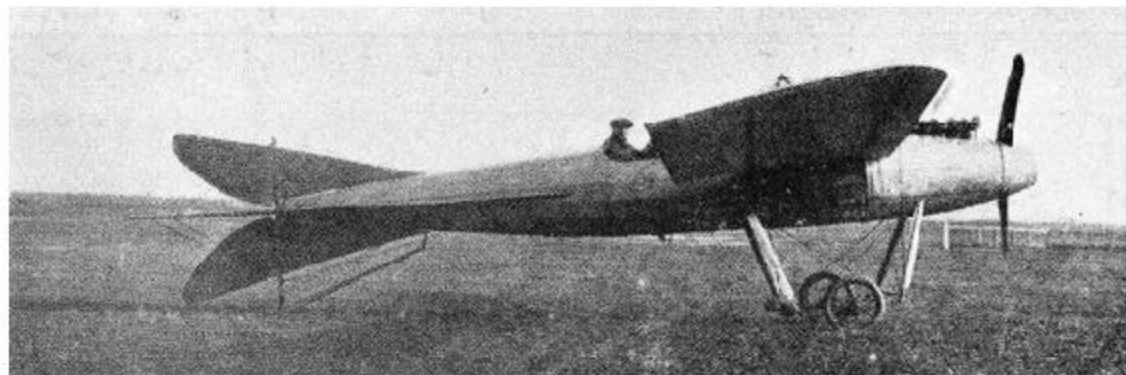

96 h.p.

		1912. Torpedo monoplane. I.	1912. Torpedo monoplane. II.
Length	feet (m.)	29-3/4 (9.10)	27 (8.2)
Span	feet (m.)	40-3/4 (12.4)	35-1/2 (10.8)
Area	sq. feet (m <sup>2</sup> .)	291 (27)	215 (20)
Weight	total lbs. (kgs.)	1984 (900)	2204 (1000)
	useful lbs. (kgs.)	1322 (600)	1543 (700)
Motor	h.p.	100 Argus	96 Mercedes
Speed	max. m.p.h. (km.)	...	...
	min. m.p.h. (km.)	84 (135)	87 (140)
Endurance	hrs.	3	3
Number built during 1912		2	2

*Remarks.*—

## M

### MARS.

Deutsche Flugzeugwerke G. m. b. H., Lindenthal bei Leipzig. Established 1911. This is one of the most important and successful aviation works in Germany. Capacity: from 80 to 100 machines a year.



Mars. Monoplane.

		1912-13. Monoplane.	1912-13. Biplane.	1913. Hydro- aeroplane.
Length	feet (m.)	31 (9.7)	31 (9.7)	Building.
Span	feet (m.)	55-1/4 (16.8)	57 (17.8)	
Area	sq. feet (m <sup>2</sup> .)	376 (35)	495 (46)	
Weight	total lbs. (kgs.)	1234 (560)	1434 (650)	
	useful lbs. (kgs.)	1808 (820)	2006 (910)	
Motor	h.p.	95 N.A.G.	95 Mercedes	
Speed	max. m.p.h. (km.)	120 (75)	115 (71)	
	min. m.p.h. (km.)	...	...	
Endurance	hrs.	5-6	4-6	
Number built during 1912		6	16	

Remarks.—

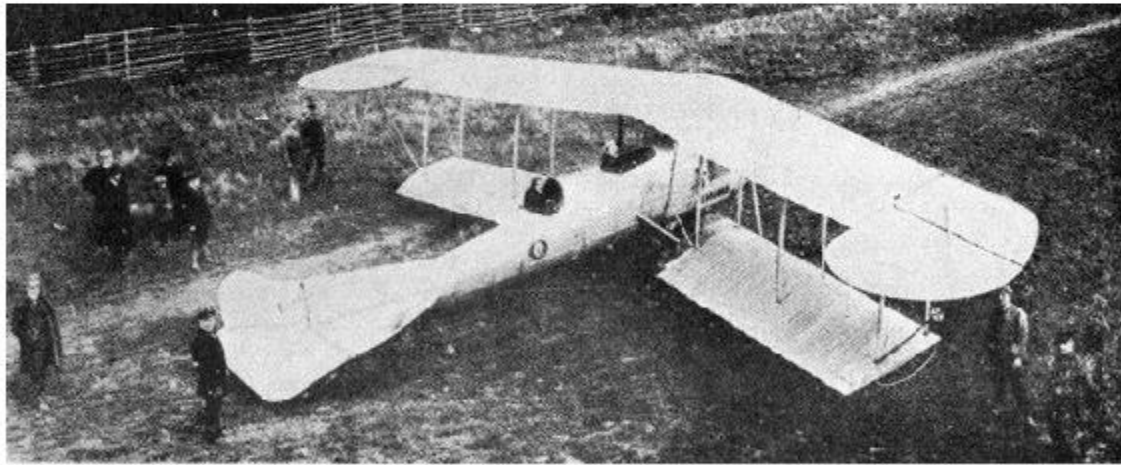

Mars. Biplane.

## MROZINSKI.

Bernard Mrozinski, Berlin-Wilmersdorf. Established 1912.

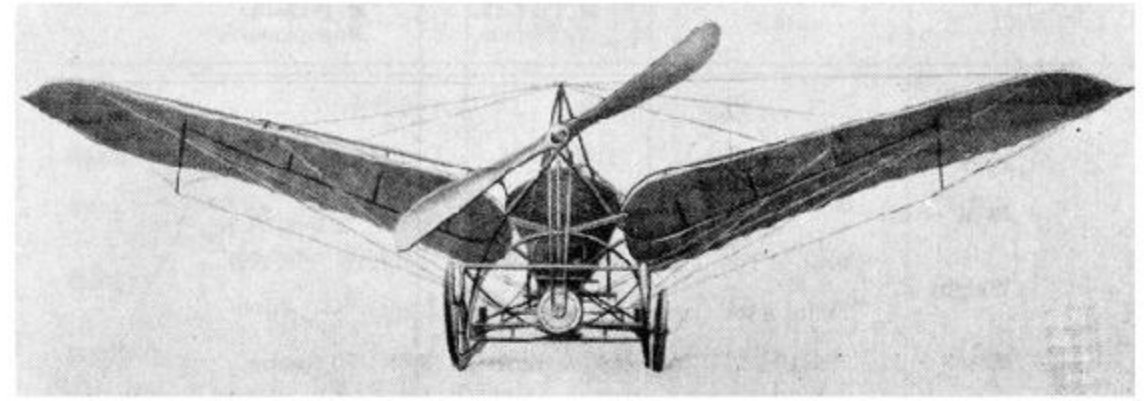

**Length**, 23 feet (7 m.) **span**, 32¾ feet (10 m.) **area**, 215 sq. feet (20 m<sup>2</sup>.)  
**Weight**.—661 lbs. (300 kgs.) **Motor**.—20 h.p. Anzani. **Speed**.—50 m.p.h. (80 km.)

Remarks.—One machine only built in 1912.

O

## OERTZ.

Max Oertz, Yachtwerft, Reiherstieg b. Hamburg. Famous yacht builder. Commenced aeroplane construction in 1911. Existing models as below. Capacity about 25 machines a year.

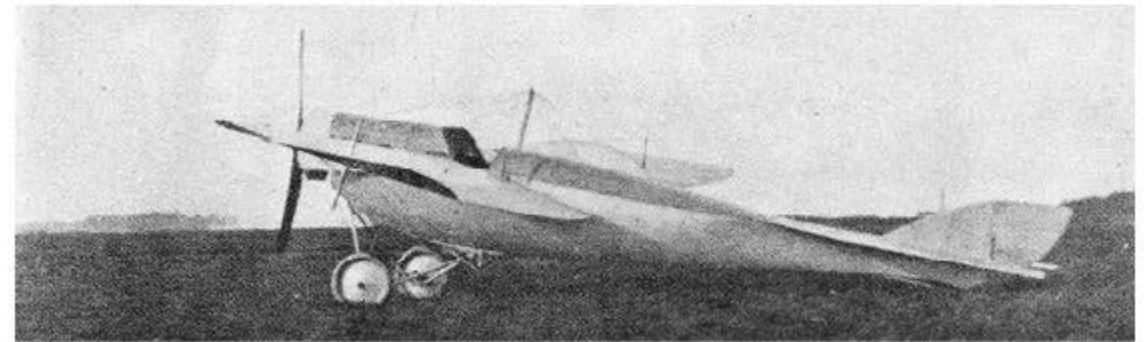

1912-13 model.

		M 1911-12. Monoplane.	M 1912-13. Monoplane.
Length	feet (m.)	29-1/2 (9)	30-1/4 (9.2)
Span	feet (m.)	41-3/4 (12.75)	41-3/4 (12.75)
Area	sq. feet (m <sup>2</sup> .)	247 (23)	263 (24.5)
Weight	total lbs. (kgs.)	948 (430)	1212 (550)
	useful lbs. (kgs.)	...	...
Motor	h.p.	70 Gnome	70 Gnome
Speed	max. m.p.h. (km.)	69 (110)	75 (120)
	min. m.p.h. (km.)	...	...
Endurance	hrs.	3	4
Number built during 1912		3	1

## OTTO.

Gustav Otto, Flugmaschinenwerke, Schleissheimer Str. 135, Munich. Started building in 1911. Present max. capacity about 30 machines a year.

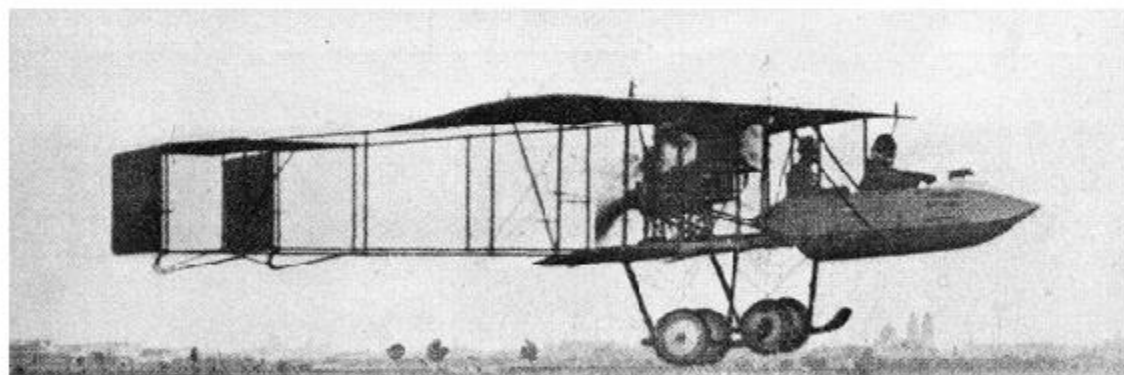

		M 1912. Biplane.
Length	feet (m.)	...
Span	feet (m.)	...
Area	sq. feet (m <sup>2</sup> .)	...
Weight	total lbs. (kgs.)	...
	useful lbs. (kgs.)	...
Motor	h.p.	100 A. G. Otto.
Speed	max. m.p.h. (km.)	69 (110)
	min. m.p.h. (km.)	...
Endurance	hrs.	6-8
Number built during 1912		6

Remarks.—All 1912 machines purchased for German Army.

## P

## PEGA-EMICH.

Flugtechnische und mechanische Werke vorm. Pega & Emich, Falterstrasse 13-15, Griesheim, Frankurt-a-M. Commenced building with a 6-decker in 1910. Capacity: small.



		1913. Buteno monoplane.
Length	feet (m.)	39-1/4 (12)
Span	feet (m.)	46 (14)
Area	sq. feet (m <sup>2</sup> .)	355 (33)
Weight	total lbs. (kg.)	838 (380)
	useful lbs. (kg.)	1102 (500)
Motor	h.p.	70 Argus
Speed	max. m.p.h. (km.)	62 (100)
	min. m.p.h. (km.)	...
Endurance	hrs.	2
Number built during 1912.		...

#### PIPPART-NOLL.

Pippart-Noll-Flugzeugbau, Mannheim.



Type.		P. N. 1 Sporting. 1912.	P. N. 2. "Uberland" 1912.	P. N. 3. Military. 1913.
Length	feet (m.)	31 (9.50)	28 (8.50)	28 (8.50 also 7)
Span	feet (m.)	34-1/2 (10.50)	39-1/3 (12)	45 (13.70)
Area	sq. feet (m <sup>2</sup> .)	215 (20)	280 (26)	300 (28)
Weight	machine lbs. (kgs.)	617 (280)	838 (380)	1234 (560)
	useful lbs. (kgs.)	330 (150)	463 (210)	441 (200)
Motor	h.p.	70 Argus	70 Argus	70 Argus
Speed	max. m.p.h. (km.)	59 (95)	62 (100)	68 (110)
	min. m.p.h. (km.)	...	...	50 (80)
	Endurance	hrs.	...	...
Number built during 1912		1	1	1

#### R

#### RUMPLER.

E. Rumpler, Luftfahrzeugbau G. m. b. H., Siegfriedstrasse 202, Berlin-Lichtenberg, also Johannisthal b. Berlin. Established 1909 by E. Rumpler and R. Haessner for the construction in Germany of *Etrich* (see Austria) monoplanes. These now vary considerably from the original *Etrich*. Capacity at present about 200 to 300 machines a year. Standard models are as follows:

—

		1912. Monoplane.	1912. "Taube."	1913. Hydro.
Length	feet (m.)	29-3/4 (9.50)	34 (10.30)	33 (10)
Span	feet (m.)	41-1/2 (12.65)	46 (14)	49-1/4 (15)
Area	sq. feet (m <sup>2</sup> .)	247 (23)	336 (32)	387 (36)
Weight	total lbs. (kgs.)	1398 (630)	1190 (540)	1328 (600)
	useful lbs. (kgs.)	771 (350)	551 (230)	485 (220)
Motor	h.p.	95 Mercedes	100 Argus	100 Argus
Speed	max. m.p.h. (km.)	81 (130)	59 (95)	56 (90)
	min. m.p.h. (km.)	...	...	...
Endurance	hrs.	6-7	4-6	...
Number built during 1912		1	60	3



Rumpler. Hydro-aeroplane.



Rumpler. Monoplane.

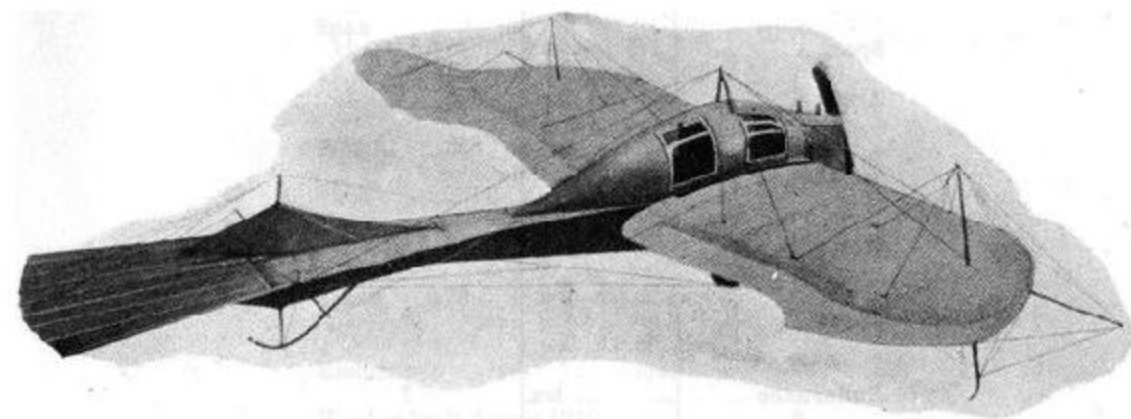

Rumpler. "Taube." With limousine body.

## RUTH-ROHDE.

Ruth-Rohde, Motorgleitflieger, G. m. b. H., Wandsbeck. Established 1912. Capacity: small.

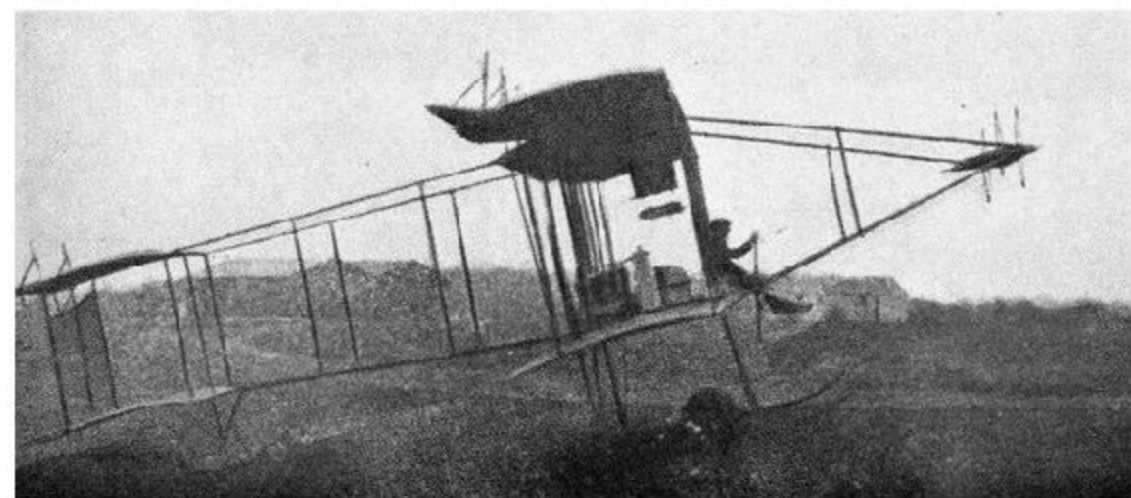

		1912. Biplane I.	1912. Biplane II.
Length	feet (m.)	26-1/4 (8)	26-1/4 (8)
Span	feet (m.)	36 (11)	45 (14)
Area	sq. feet (m <sup>2</sup> .)	590 (55)	700 (65)
Weight	total lbs. (kgs.)	1653 (750)	1764 (800)
	useful lbs. (kgs.)	...	...
Motor	h.p.	75 Argus	75 Argus
Speed	max. m.p.h. (km.)	55 (90)	55 (90)
	min. m.p.h. (km.)	...	...
Endurance	hrs.	3	3-4
Number built during 1912.		1	1

## S

### SCHELIES.

Richard Schelies, Conventstrasse 5 und 5b, Hamburg 23. Flying Station, etc.: Dockenhuden a/ Elbe.



		1913. Hydro-monoplane.
Length	feet (m.)	23 (7)
Span	feet (m.)	29-1/2 (9)
Area	sq. feet (m <sup>2</sup> .)	323 (30)
Weight	total lbs. (kgs.)	705 (320)
	useful lbs. (kgs.)	220 (100)
Motor	h.p.	Rheinische Aero 35
Speed	m.p.h. (km.)	...

### SCHULZE.

Gustav Schulze, Flugzeug Werke, Burg b. Magdeburg. Schulze began to build in 1910 light monoplanes, generally along *Santos-Dumont* lines. Maximum present capacity about 12 machines a year.

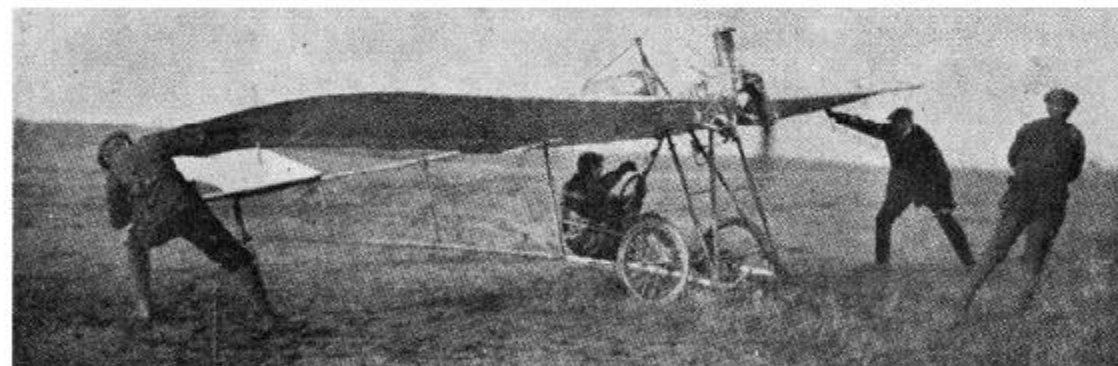

		1912. I.	1912. II.	1912. III (2-seater).	1913. I (2-seater).
Length	feet (m.)	19-3/4 (6)	26-1/4 (8)	21-1/3 (6.50)	23 (7)
Span	feet (m.)	26-1/4 (8)	34-1/2 (10.50)	28 (8.50)	29-1/2 (9)
Area	sq. feet (m <sup>2</sup> .)	172 (16)	215 (20)	172 (16)	194 (18)
Weight	total lbs. (kgs.)	330 (150)	441 (200)	441 (200)	551 (250)
	useful lbs. (kgs.)		...	...	...
Motor	h.p.	24-30 Hilz	24-30 Hilz	35 Haacke	35 Haacke
Speed	max. m.p.h. (km.)	48 (77)	53 (85)	56 (90)	53 (85)
	min. m.p.h. (km.)	...	43 (70)	50 (80)	46 (75)
Number built during 1912.		1	3	1	Building.

### SIGISMUND.

Prinz Sigismund von Preussen, Berlin.

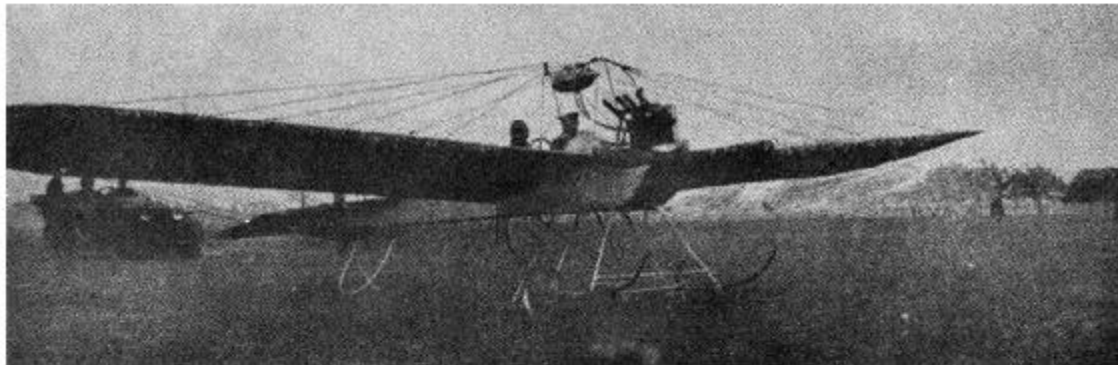

Model and date.		Monoplane.
Length	feet (m.)	29-1/2 (9)
Span	feet (m.)	42-3/4 (13)
Area	sq. feet (m <sup>2</sup> .)	323 (30)
Weight	total lbs. (kgs.)	950 (430)
	useful lbs. (kgs.)	395 (180)
Motor		Argus, 100
Speed	max. m.p.h. (km.)	56 (90)
Number built during 1912		2

U

### UNION FLUGZEUGWERKE.

Union Flugzeugwerke G. m. b. H. Elsenstrasse 106 & 107, Berlin s. o. 36. Established 1913. Capital 500,000 marks. Capacity of works: 20 machines a year.

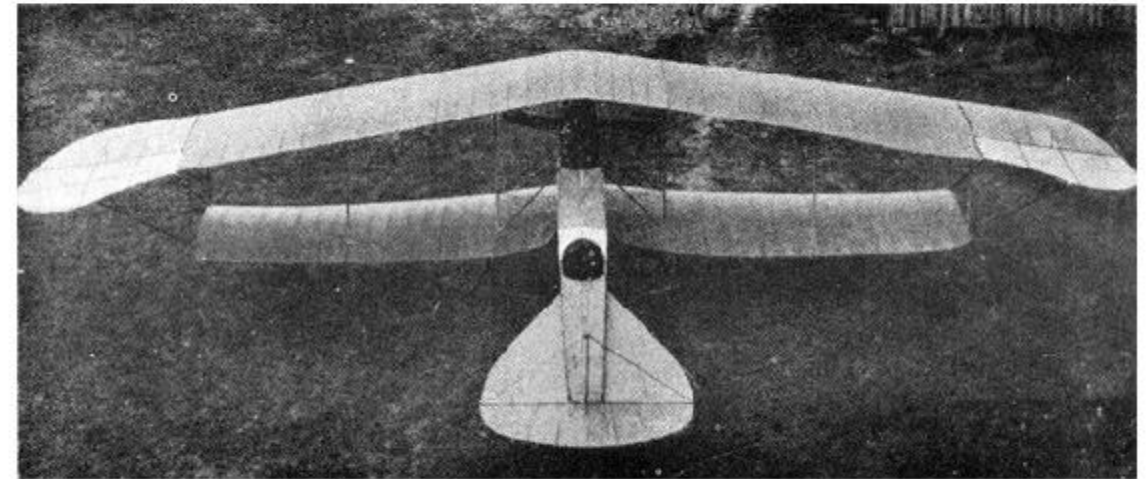



Model and date.		<b>Bomhard. Pfeilflieger, 1913.</b>
Length	feet (m.)	32-3/4 (10)
Span	feet (m.)	59 (18)
Area	sq. feet (m <sup>2</sup> .)	450 (42)
Weight	total lbs. (kgs.)	1235 (560)
	useful lbs. (kgs.)	617 (280)
Motor		100 Argus
Speed	max. m.p.h. (km.)	69 (110)
	min. m.p.h. (km.)	62 (100)
Number built during 1912		New firm

## W

### WRIGHT.

Flugmaschine Wright, G. m. b. H., Adlershof, bei Berlin. Company formed to trade in German rights for the Wright Bros.' patents. Considerable departures have been made from the U.S. pattern, and some have been built with a single propeller only. Capacity of works 100-150 a year.

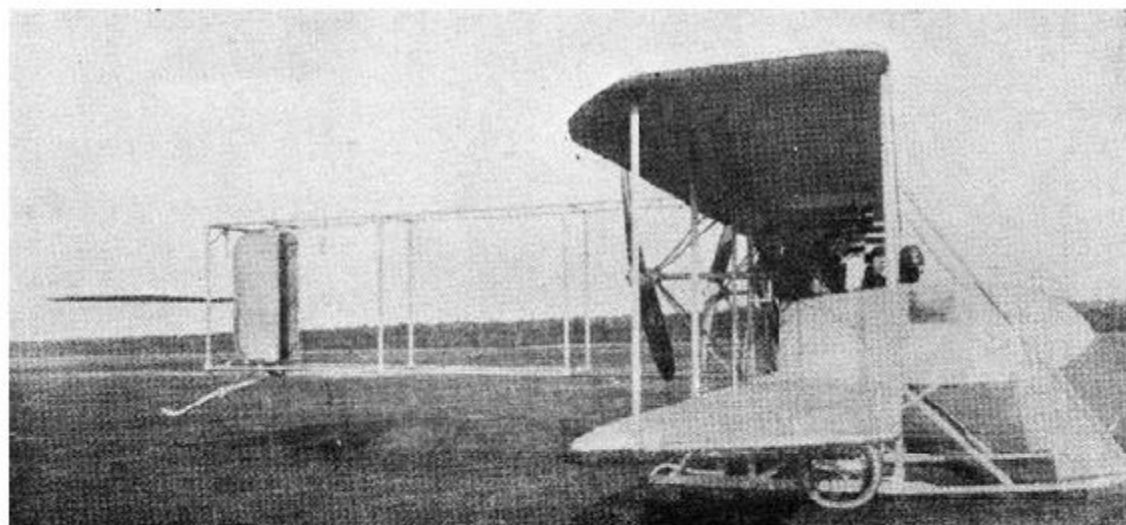

Armoured war aeroplane.

		<b>1912.</b> Military.	<b>1913.</b> Sporting.	<b>1913. Military.</b>	<b>1913. Military. 4-</b> seater.
Length	feet (m.)	28 (8.50)	26-1/2 (8.20)	31-1/2 (9.65)	...
Span	feet (m.)	39-1/2 (12.20)	31 (9.60)	40-1/2 (12.50)	44-1/4 (13.50)
Area	sq. feet (m <sup>2</sup> .)	452 (42)	323 (30)	463 (43)	463 (43)
Weight	total lbs. (kgs.)	992 (450)	837 (380)	1433 (650)	1653 (750)
	useful lbs. (kgs.)	...	...	...	882 (400)
Motor	h.p.	55 N.A.G.	55 N.A.G.	100 Argus or Mercedes	100
Speed	max. m.p.h. (km.)	50 (80)	60 (95)	60 (95)	60 (95)
	min. m.p.h. (km.)	...	...	...	...
Number built during 1912		10	?	...	...

## Z

### ZIEGLER.

Ziegler, Potsdam. Established late in 1912.

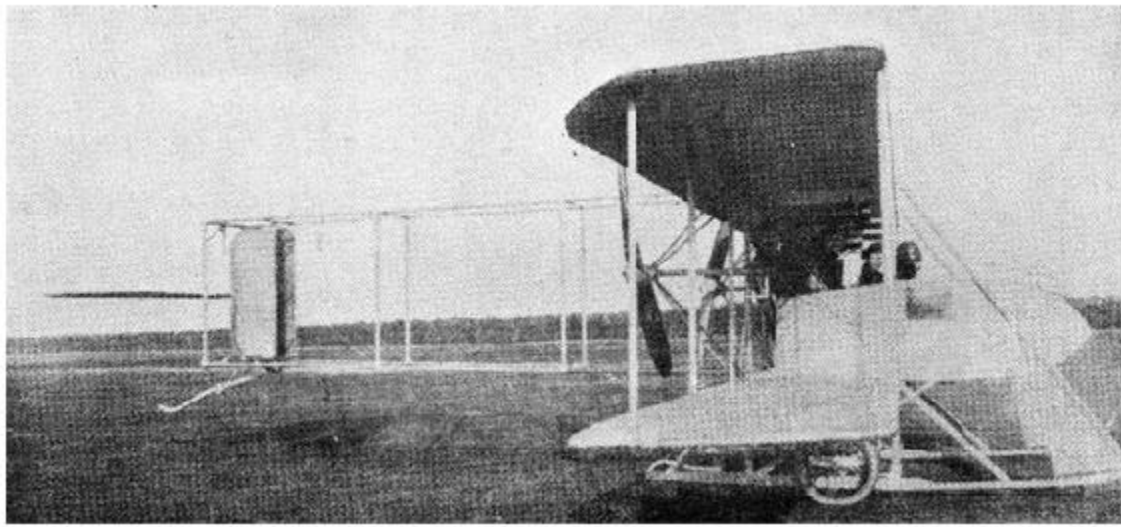

## GERMAN DIRIGIBLES.

(Approximately 1000 m<sup>3</sup>=35,000 c. feet.)

Military.

		1912-13. Monoplane.
Length	feet (m.)	31 (9.50)
Span	feet (m.)	39-1/3 (12)
Area	sq. feet (m <sup>2</sup> .)	344 (32)
Weight	total lbs. (kgs.)	881 (400)
	useful lbs. (kgs.)	992 (450)
Motor	h.p.	100 N.A.G.
Speed	max. m.p.h. (km.)	60 (90)
	min. m.p.h. (km.)	...
Endurance	hrs.	2
Number built in 1912		1

Date.	Name.	Make.	Type.	Capacity in m <sup>3</sup> .	Total H.P.	Speed. m.p.h. (km.)	Remarks.
1908	Z I	Zeppelin 3b	r.	12100	190	29 (46)	as rebuilt
1910	Z II	Zeppelin 9b	r.	18000	345	35 (56)	as rebuilt
	L. S I	Schütte Lanz 1	r.	20000	540	40 (62)	
1912	Z III	Zeppelin 12	r.	17800	450	49 (79)	was Schwaben L. Z 10
	L I	Zeppelin 14	r.	22000	450	48 (77-1/2)	Naval: 1 gun
1913	Z IV (Z I Ersatz)	Zeppelin 15	r.	21000	450	48 (77-1/2)	4 guns
Building.	L II	Zeppelin 16	r.	21000	450	48 (77-1/2)	Naval: bldg. 4 guns
	S. L II	Schütte Lanz 2	r.	26000	450	48 (77-1/2)	Building
1908	P I	Parseval 2	n.r.	3800	85	33-1/2 (54)	
1911	P III	Parseval 11	n.r.	11000	400	42-1/2 (67)	
1912	M I	Gross-Bas 2	s.r.	6000	150	28 (45)	old 1908 rebuilt
	M II	Gross-Bas 3	s.r.	6000	150	28 (45)	old 1909 rebuilt
	M III	Gross-Bas 4	s.r.	9000	300	42-1/2 (67)	old 1910 rebuilt

1913	M IV	Gross-Bas 5	s.r.	12000	400	44-1/2 (70)	old 1911 <i>rebuilt</i>
	P II ersatz	Parseval 8	n.r.	8250	300	41 (66)	Building
	P IV	Parseval 16	n.r.	10000	360	45 (72)	Building

Private.<sup>[D]</sup>

Date.	Name.	Make.	Type.	Capacity in m <sup>3</sup> .	Total H.P.	Speed. m.p.h. (km.)	Remarks.
1910	DEUTCHLAND 2	Zeppelin 6a	r.	15000	345	36 (58)	Deutschland <i>Ersatz Delag</i>
1912	V. LUISE	Zeppelin 11	r.	17000	450	40 (62)	Delag
	HANSA	Zeppelin 13	r.	17000	450	40 (62)	Delag
1913 <i>Bldg.</i>	SACHSEN	Zeppelin 17	r.	21000		48 (77-1/2)	<i>Building.</i> Delag
1908	P. L 1	Parseval 1	n.r.	3200	185	20 (32)	
1910	STOLLWERCK	Parseval 6	n.r.	9000	220	31 (50)	
1911	P. L 9	Parseval 9	n.r.	2200	50	25 (40)	Sporting <sup>[E]</sup>
	R 2	Ruthenberg 2	n.r.	1700			Experimental
1912	SUCHARD	Suchard reb'lt	n.r.	6730	200	17 (28)	to be <i>rebuilt</i> 1913
	P. L XII	Parseval 12	n.r.	8800	220	33-1/2 (54)	
1913	P. L 10	Parseval 10	n.r.	2200	50	25 (40)	<i>Building:</i> delayed
	R 3	Ruthenberg 3	n.r.	2700			Building

[D] P.L 9 reported sold to Turkey, April, 1913.

[E] Three other dirigibles, *Unger*, *Veeh*, and *Siemens-Schuckert*, are generally credited to Germany. Of these *Unger* is merely a project. *Veeh* has been talked about for four years, but has never reached completion. *Siemens-S.* has ceased to exist.

### Dirigible Sheds.

(See Note.)

Bickendorf bei Köln.  
Biesdorf bei Berlin.  
\*Bitterfeld (*Parseval Co.*)  
Breslau.  
Cuxhaven.  
Düsseldorf (*Delag*)  
Frankfurt a/m.  
Friedrichshafen (*Zeppelin Co.*)  
Gotha.  
Hamburg (*Delag*).  
\*Johannisthal (*L.V.G.*)  
Kiel (*private*).  
Königsberg i/Pr.  
Leichlingen.  
Manzell (*Zeppelin Co.*)  
Metz.  
\*München (*private*).  
Oos bei Baden-Baden (*Delag*).  
Potsdam (*Delag*)  
Reinickendorf bei Berlin.  
Rheinau.  
Strassburg.  
Stuttgart.  
Thorn.

Note.—Unless otherwise stated the above are military sheds. All private ones capable of holding *Zeppelins* are subsidised. \*=not large enough for *Zeppelins*.

### Dirigible Pilots.

For M. dirigibles.

Geertz, Oblt.  
George, Hptm.  
v. Jena, Hptm.  
Kirchner, Oberltm.

Lohmuller, Hptm.  
Masius, Oberltm.  
v. Muller, Hptm.  
Nichisch v. Rosenegk, Oberltm.  
Schlutter, Obltn.  
Sperling, Major.  
von Zech, Obltn.

### Dirigible Pilots.

Z=Zeppelin. S=Schutte-Lanz. P=Parseval *pilot*.

(The number after each name is the Imperial Ae. C. certificate number.)

Z Abercron, H. v. Major (1)  
Z Bassus, K. v. (28)  
Z Bentheim, Kapt. Lt. a. D. v. (34)  
Z Blew (25)  
Clouth, R. (8)  
P Dinglinger, F. (2)  
Z Dorr, W. E. (21)  
Z Durr (9)  
Z Eckener, Dr. (10)  
P Forsbeck, Ob. Lt. A. D. (11)  
Z Glund, F. (23)  
Z Hacker, (12)  
P Hackstetter, Reg. B. a. D. (13)  
Z Hanne, G. (32)  
Z Heinen, A. (22)  
Z Holzmann, Ob. Lt. A. (26)  
S Honold, R. (29)  
P Hormel, Kap. Lt. (14)  
P Jordens, W. (19)  
P Kehler, R. v. (6)  
P Kiefer, T. (5)  
Kleist, Hptm. a. D. v. (15)  
P, Z Krogh, Hptm. a. D. v. (16)  
Z Lange, K. (30)  
Z Lau (17)  
Z Lempertz, E. (33)  
Z Mechlenburg, W. C. (35)  
Z Meyer, Ob. Lt. E. (27)  
P Parseval, A. v. (4)  
Z Stahl, K. (31)  
P Stelling, A. (3)

Z Sticker, J. (24)  
P Thewaldt, C. H. (20)  
Z Zeppelin, Graf. v. (7)  
Z Zeppelin, Graf. F. v. junr. (18)

### GERMAN MILITARY CLASS—GROSS-BASENACH. (Semi-rigid)

Up to date, these vessels have been designed by Major Gross and Oberingenieur Basenach.

The utmost secrecy is observed as to their details.

The system of employing 2 ballonets has been borrowed from the *Parseval* type, and presumably the *Parseval* system of working the automatic valves has also been adopted.

In all other features, these ships appear to resemble the French *Lebaudy* type, the shape of the hulls being rather better.

List of ships built, re-built and re-building of this type:—

- |                   |                                |                          |                       |
|-------------------|--------------------------------|--------------------------|-----------------------|
| 1                 | = <b>Aeronautical Society.</b> | (1,800 m <sup>3</sup> )  | <i>non-effective.</i> |
| 2 (reconstructed) | = <b>M 1, Military.</b>        | (6,000 m <sup>3</sup> )  |                       |
| 3                 | " = <b>M 2, Military.</b>      | (6,000 m <sup>3</sup> )  |                       |
| 4                 | " = <b>M 3, Military.</b>      | (9,000 m <sup>3</sup> )  |                       |
| 5                 | " = <b>M 4, Military.</b>      | (12,000 m <sup>3</sup> ) |                       |

**M I (re-built 1912), & M II (re-built 1912). Military.**

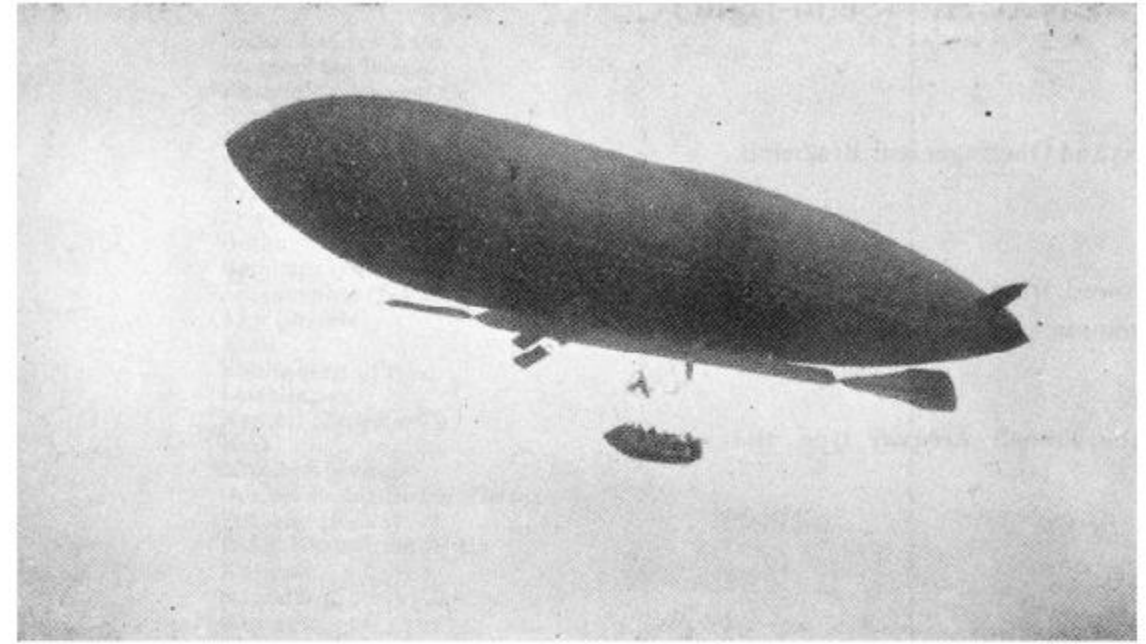

**Length,** 242¾ feet (74 m.) **maximum diameter,** 36 feet (11 m.) **capacity,** 212,000 c. feet (6,000 m<sup>3</sup>) **total lift,** 13,338 lbs. (6,050 kg.) *about 6 tons*

**Useful lift.**—2,756 lbs. (1,250 kgs.)=about 1¼ tons.

**Gas bag.**—Continental rubber cloth, diagonal thread. Tapering shape.

**Ballonet.**—One-fifth of total volume.

**Motors.**—2-75 h.p. Daimler. 2 propellers, with 3 aluminium blades.

**Speed.**—About 28 m.p.h. (45 km.).

*Remarks.*—*M I* was originally built in 1908, re-built and enlarged 1910 and again in 1912. *M II* built 1909, re-constructed 1912.

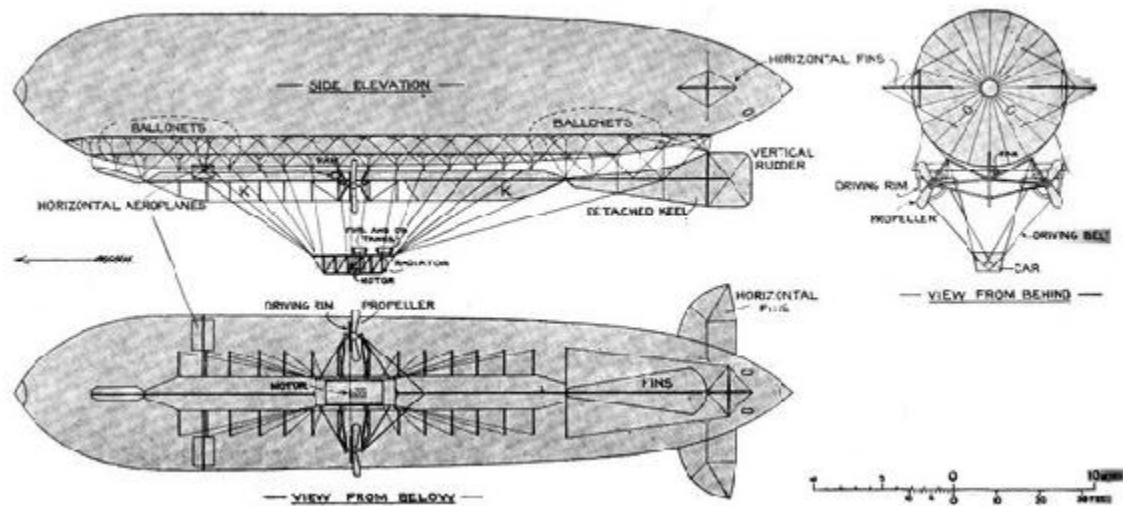

### M IV (re-built 1913). Military.

**Maximum length**, 334¾ feet (102 m.) **maximum diameter**, 44½ feet (13.5 m.) **volume**, 423,800 c. feet (12,000 m<sup>3</sup>.)

**Total lift.**— lbs. ( kgs.) **Useful lift**, lbs. ( kgs.)

**Gas bags.**—Continental.

**Motors.**—2 Körting, 100 h.p. each = total 200 h.p.

**Speed.**—44½ m.p.h. (70½ k.p.h.)

**Propellers.**—4 (two for each motor.) Carried on outriggers projecting from the car.

*Remarks.*—Departs from previous practice in having two separate cars, each of which contains one motor. Originally built in 1911 of 7,500 m<sup>3</sup>. Re-built 1912-1913 to details as above.

### M III (re-built 1912). Military.

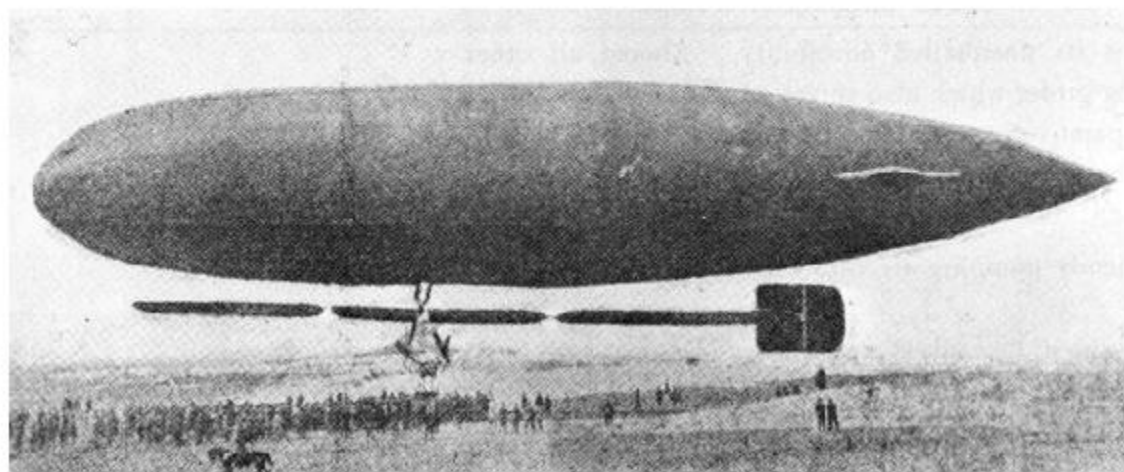

**Length**, 295¼ feet (90 m.) **diameter**, 39-1/3 feet (12 m.) **volume**, 317,800 c. feet (9,000 m<sup>3</sup>.)

**Motors.**—4 Körting of 75 h.p. each = 300 h.p. total.

**Speed.**—19 metres per second = 42 m.p.h. (68½ k.p.h.)

**Propellers.**—2, on outriggers from car, chain-driven.

*Remarks.*—Built 1910. Burned 13th September, 1911. Rebuilt 1912.

### PARSEVAL CLASS (Non-rigid).

Luftfahrzeug-Gesellschaft m.b.H, Berlin, W. 62.

When the "Motorluftschiff Studien Gesellschaft" was formed at the instigation of the German Emperor, a committee was formed to acquire an experimental airship of the most promising type. Major Von Parseval's first airship was selected, and since that time the above company has confined itself to improving this type, and to making exhaustive and costly researches, all of which have been embodied in successive ships.

The characteristic feature of every one of these craft is its unequalled portability. Almost all other so-called Non-rigid vessels distribute the load by means of a long girder which also serves as a car. This girder is awkward to pack up and transport. Parseval uses a comparatively small car, and distributes the weight by hanging it further below the balloon than usual, and also by using 2 ballonets which are placed one near each end of the gas bag.

These 2 ballonets enable the ship to be trimmed by merely pumping air into either at the expense of the other.

Another essential feature of the type is the system by which the valves are worked automatically. At the present time there is no other system of valve working so reliable as this.

A third essential feature of the class is the use of a swinging car, in such a manner that pitching, due to alterations of propeller thrust, is automatically checked by an alteration of the position of the centre of gravity.

A fourth feature is the use of limp propeller blades. A propeller of this type is very easily packed up.

The shape of these vessels is in accordance with the experiments of Professor Prandtl.

Ships of this class built or building (figures supplied by the Parseval Co.):—

EXPERIMENTAL PARSEVAL	2,300 m <sup>3</sup> .
P. L. 1 Kals. Ae. C	3,200 m <sup>3</sup> .
MILITARY P I	4,000 m <sup>3</sup> .
MILITARY P II	6,600 m <sup>3</sup> .
P. L. 4 Austrian Military	2,300 m <sup>3</sup> .
P. L. 5 Luftverkehrs Gesellschaft	1,450 m <sup>3</sup> .
P. L. 6 "	9,000 m <sup>3</sup> .
P. L. 7 Russian Army	7,600 m <sup>3</sup> .
P. L. 8 MILITARY P II Ersatz	8,250 m <sup>3</sup> .
P. L. 9 Luftverkehrs Gesellschaft	2,200 m <sup>3</sup> .
P. L. 10 Motorluftschiff Studien Gesellschaft	2,200 m <sup>3</sup> .
MILITARY P III	11,000 m <sup>3</sup> .
P. L. 12 Luftverkehrs Gesellschaft	8,800 m <sup>3</sup> .
P. L. 13 Japanese Army	8,500 m <sup>3</sup> .
P. L. 14 Russian Army	9,500 m <sup>3</sup> .
P. L. 15 Italian Army	10,000 m <sup>3</sup> .
P. L. 16 MILITARY P IV, Prussian Army	10,000 m <sup>3</sup> .
P. L. 17 Italian Army	10,000 m <sup>3</sup> .
P. L. 18 British Navy	8,800 m <sup>3</sup> .

(Of the above, the Experimental is no longer in existence, P. 2 is out of service, and P. L. 3 has been burned and destroyed).

**PARSEVAL (P.L. 1). (1908.) (Belongs to the Kaiserl. Aero Club.) (Parseval class.)**

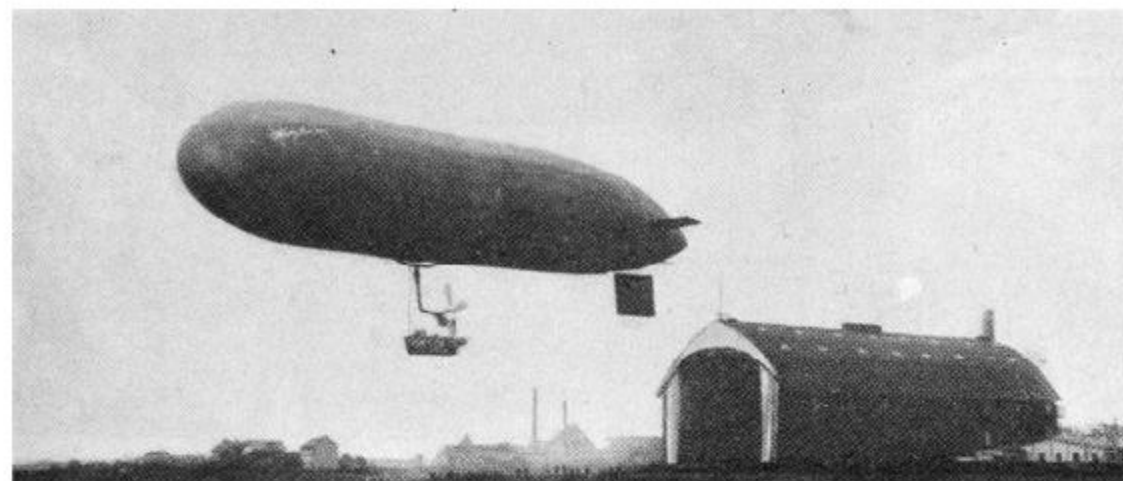

**Length**, 197 feet (60 m.) **max. diam.** 31 feet (9.4 m) **capacity**, 113,000 c. feet (3,200m<sup>3</sup>) **lifting power**, 7,800 lbs. (3,583 kgs.)

**Gas bag.**—Cylindrical, with semi-conical front. Of rubber-proofed material in longitudinal strips. Pressure in ballonets and gas bag, 30 mm. of water.

**Motor.**—One 85 h.p. Daimler.

**Fuel.**—700 lbs. (325 kg.) 88 gallons (400 litres)

**Speed.**—20 m.p.h. (32 k.p.h.)

**Propeller.**—One 4-bladed. Semi-rigid Parseval.

This vessel was somewhat altered on being bought by the Society. Her essential principle is that she can be taken to pieces in a few minutes, and carried in a truck. Her main feature is that she has a ballonnet at each end. This is described in the case of type A (*P.L. 2*). This class rise with the forward ballonnet empty, and inclined up by the bow. The propeller is similar to that of *P.L. 2*. The car also is mounted on wire runners. She was originally 4,000 m<sup>3</sup>. capacity. Built 1908. Station: Bitterfeld. The car is at present in Deutsches Museum, Munich.

## PARSEVAL P.L. 2 = P. I. Military. (1908.)

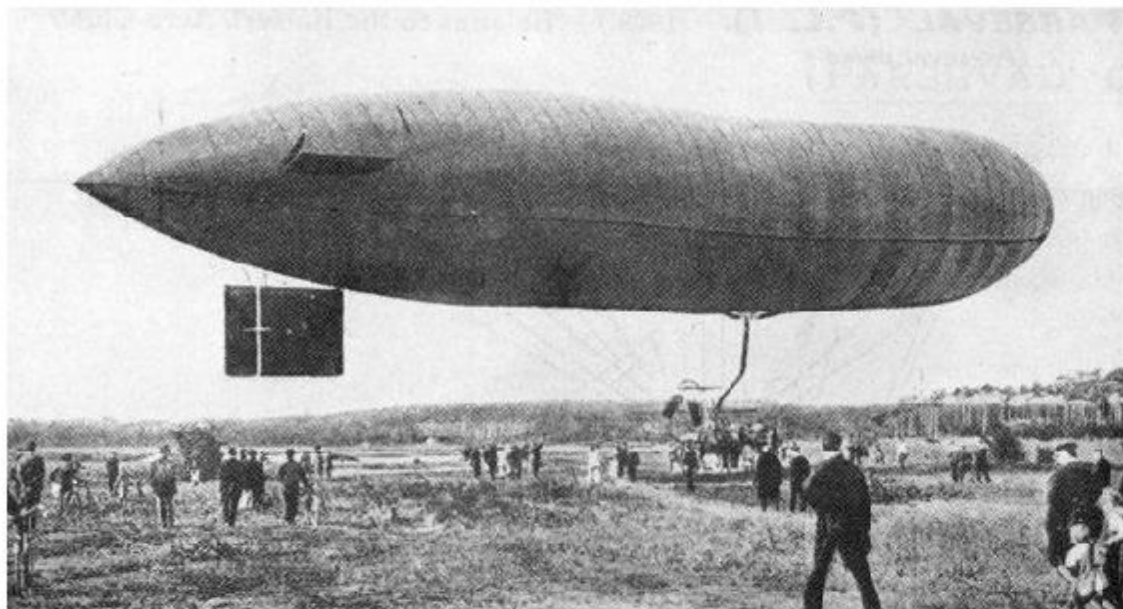

Built by the "Society for the Study of Motor Air Ships," and taken over by the German War Office.

**Length,** 197 feet (60 m.) **maximum diameter,** 34 feet (10.40 m.) **capacity,** 111,270 cubic feet (4,000 cubic m.) **lifting power,** 9,200 lbs. (4,180 kgs.)

**Gas bag.**—Front end semi-ellipsoidal with semi-axes 15.4 feet (4.7 m.) and 11.8 feet (3.6 m.), from which it increases to its maximum diameter. This is maintained for about two-thirds of its length, when it begins to taper to a point at the stern. Made of 2 layers of transverse strips of rubber proofed material, crossing each other diagonally. Fitted with a tearing strip.

**Ballonets.**—One at each end, together amounting to about one-quarter of the total capacity. Owing to this disposition, the trim can be altered, and steering effected in the vertical plane by filling either more than the other. Pressure in the ballonets and gas bag, 20 mm. of water pressure.

**Motor.**—4-cylinder 85 h.p. Daimler placed at one side of the car to give more room. 1,000 to 1,200 r.p.m.

**Propellers.**—12-1/3 feet (3.75 m.) diameter, 250 to 300 r.p.m. 4-bladed, the blades being of peculiar construction. When stopped, the fabric of which they are made hangs down limply; when running, these flaps fly out under centrifugal force.

**Speed.**—27 miles per hour. 43 kilometers per hour.

**Car.**—**Length,** 22-1/3 feet (6.8 m.) **Width** 4.1 feet (1.22 m.) Made of nickel steel, U bars, screwed together so as to take the pieces rapidly. The sides are lattice girders. The whole is boat shaped and covered with canvas. Contains motor, chart table; trail rope 480 feet (146 m.) long, weighing 220 lbs. (100 kg.) Wheel for horizontal steering at the bow. 110 gal. (500 litre) cask of petrol on the girders at the after point. 41 feet (12½ m.) below the gas bag. It is capable of swinging horizontally on wires running over rollers. Whereas without this device a forward swing of the car would lift the nose to a possibly dangerous extent, the free motion of the car shifts the centre of the gravity forward and so preserves stability.

**Steering.**—In vertical plane, by altering the trim. In horizontal plane, by a rudder of 80.7 sq. feet (7½ m<sup>2</sup>) immediately behind the vertical plane. Two fixed horizontal planes are placed at the rear end of the gas bag above the central line.

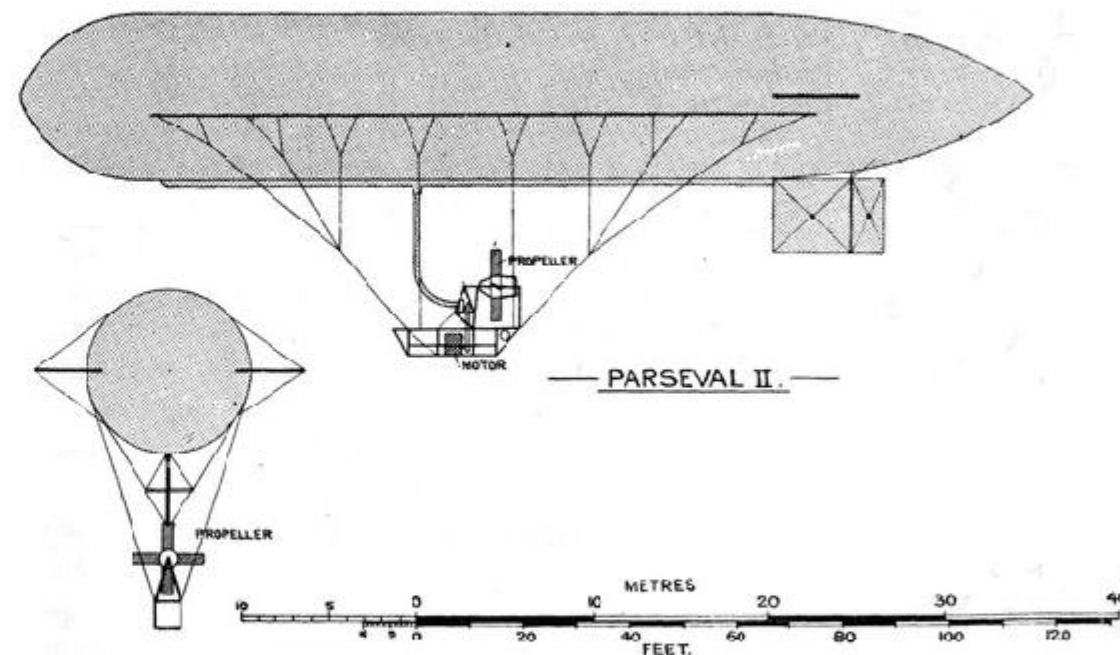

PARSEVAL II.

**Table of weights:—**



Gas bag	1,653 lbs.
Cordage	220.5 "
Trail rope	220 "
Car and motor	529 "
Fuel	770 "
Oil	160 "
Oil and fuel tanks, instruments, miscellaneous	1,637 "
Crew, passengers, ballast	1,654 "
Total	6,834 lbs.

*Note.*—This remarkably successful ship has performed a continuous flight of 11½ hours. She also remained at a height of 4,800 feet (1,500 m.) for 1 hour. She can be transported in 1 railway truck or 2 pair horse wagons, and be assembled and filled ready for ascent within 3 hours of arrival by train.

Built 1908. Station: Metz.

#### PARSEVAL P.L. 6. "Stollwerck." (1910.)

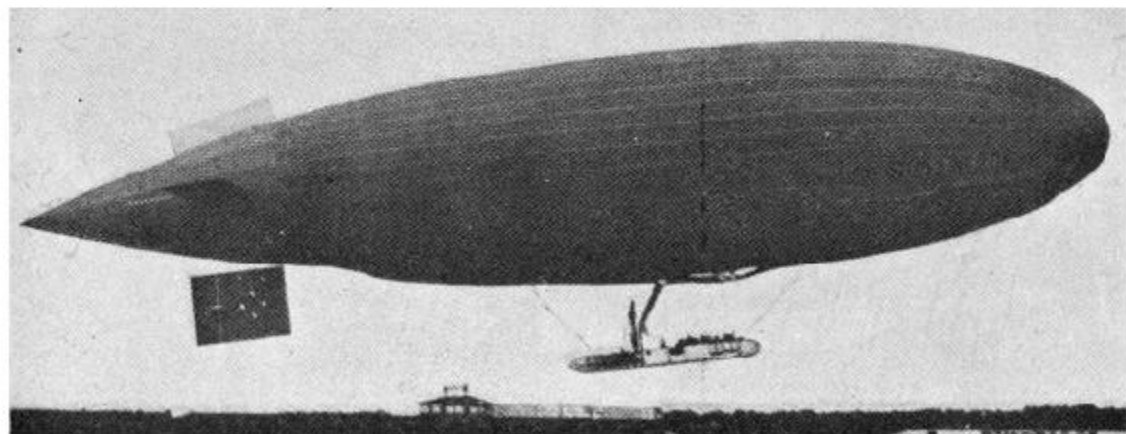

**Length**, 229¾ feet (70 m.) **Diameter**, 49¼ feet (15 m.) **Volume**, 318,000 c. feet (9,000 m<sup>3</sup>)

**Gas bags.**—Riedinger.

**Motors.**—2 N.A.G. of 110 h.p. each = 220 h.p.

**Speed.**—31 m.p.h. (50 k.p.h.)

**Propellers.**—Two 4-bladed. Semi-rigid material.

*Remarks.*—Station, Johannisthal.

#### PARSEVAL P.L. 8. = P II. Ersatz. Military. (1913.)

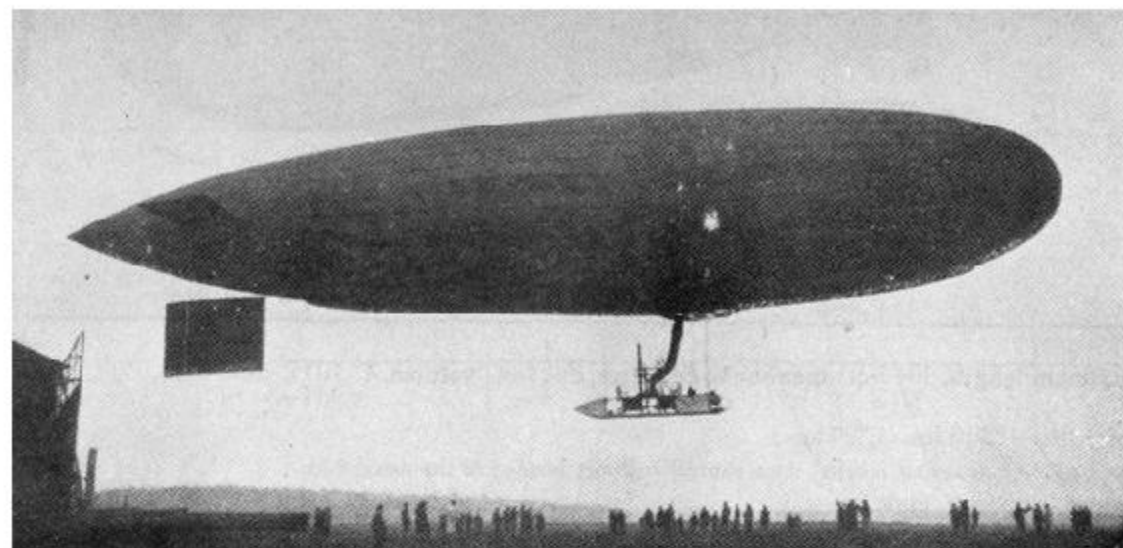

**Maximum length**, 252¾ feet (77 m.) **maximum diameter**, 50¾ feet (15.50 m.) **volume**, 290,000 c. feet (8,250 m<sup>3</sup>.)

**Total lift.**—5½ tons=12,125 lbs. (5,500 kgs.)

**Gas bags.**—2 ballonets, usual arrangement.

**Motors.**—300 h.p. made up of two 150 h.p. Daimler motors, placed one behind the other.

**Speed.**—41 m.p.h. (66 km.)

**Propellers.**—2 Parseval, 4-bladed, semi-rigid steel.

**Steering.**—As in others.

*Remarks.*—Station, Cologne, (Cöln).

**PARSEVAL P.L. 9 (1910), & 10. (Building 1913.)**

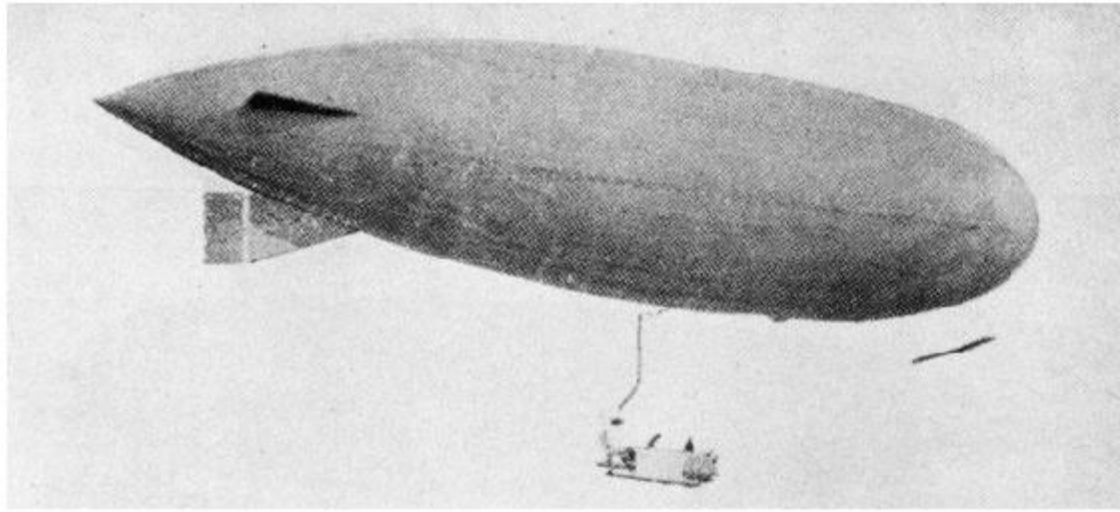

**Maximum length**, 164 feet (50 m.) **maximum diameter**, 26¼ feet (8 m.) **volume**, 77,700 c. feet (2,200 m<sup>3</sup>.)

**Total lift.**—2,910 lbs. (1,320 kgs.)

**Gas bag.**—Continental fabric. One central ballonet instead of the usual two.

**Motors.**—1 N.A.G. of 50 h.p.

**Speed.**—25 m.p.h. (40 k.p.h.)

**Propellers.**—One 2-bladed, wooden. Diameter, 9¾ feet (3 m.)

**Steering.**—Differs from other standard types, in that only one ballonet being fitted, an elevator is introduced under the bow.

**Remarks.**—Small ships for sporting purposes. A remarkably successful type of small dirigible. A small *P.L. 5*, burned 1912. *P.L. 10* delayed owing to press of other work.

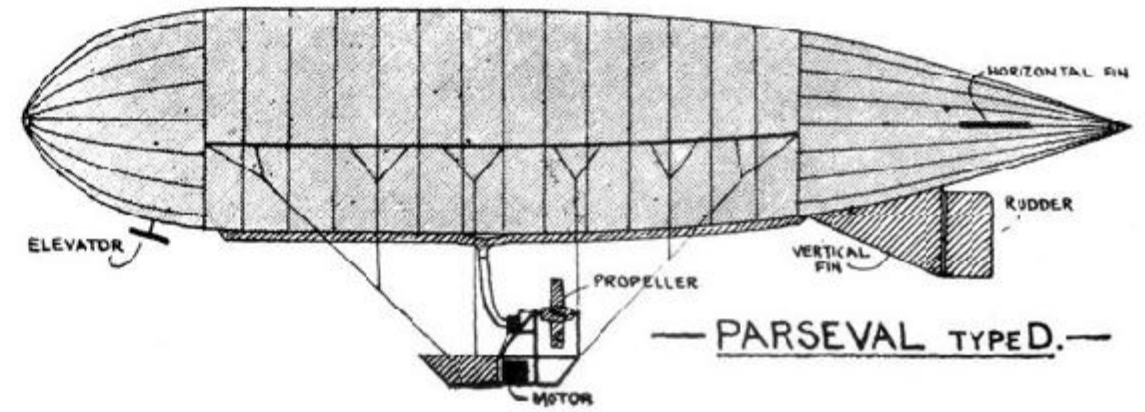

PARSEVAL TYPE D.

**PARSEVAL P.L. 11. = P. III. Military. (1911.)**

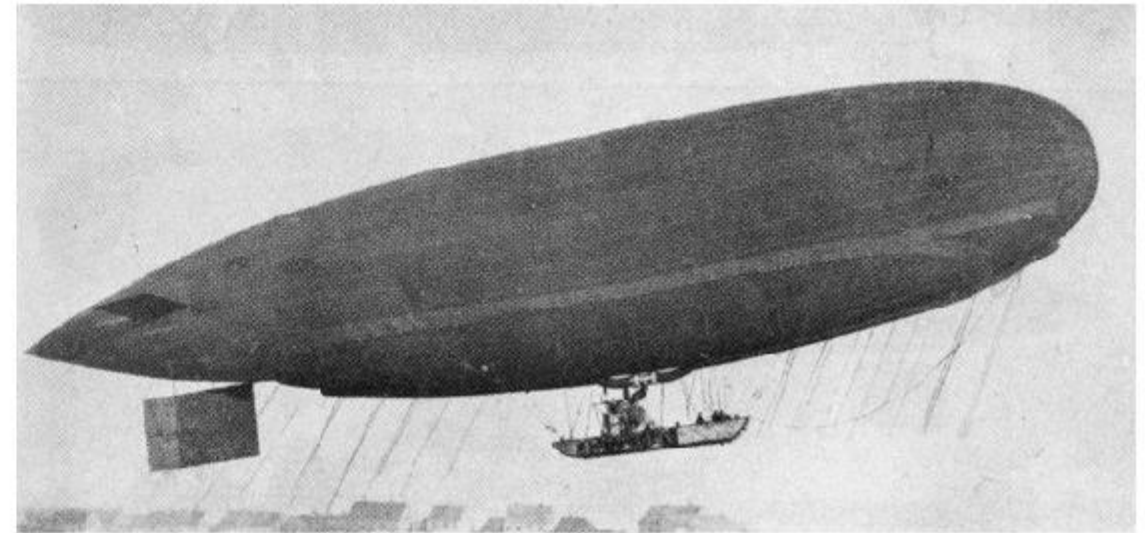

**Maximum length**, 272-1/3 feet (83 m.) **maximum diameter**, 53 feet (16.20 m.) **volume**, 388,450 c. feet (11,000 m<sup>3</sup>.)

**Total lift.**—

**Gas bags.**—

**Motors.**—2 Körting, each of 200 h.p.=400 total.

**Speed.**—42 m.p.h. (67 k.p.h.) (18.3 metres p. sec.)

**Propellers.**—Two 4-bladed Parseval.

*Remarks.*—Built 1911. Station, Koenigsberg.

### PARSEVAL P.L. 12. "Charlotte." (1912.)

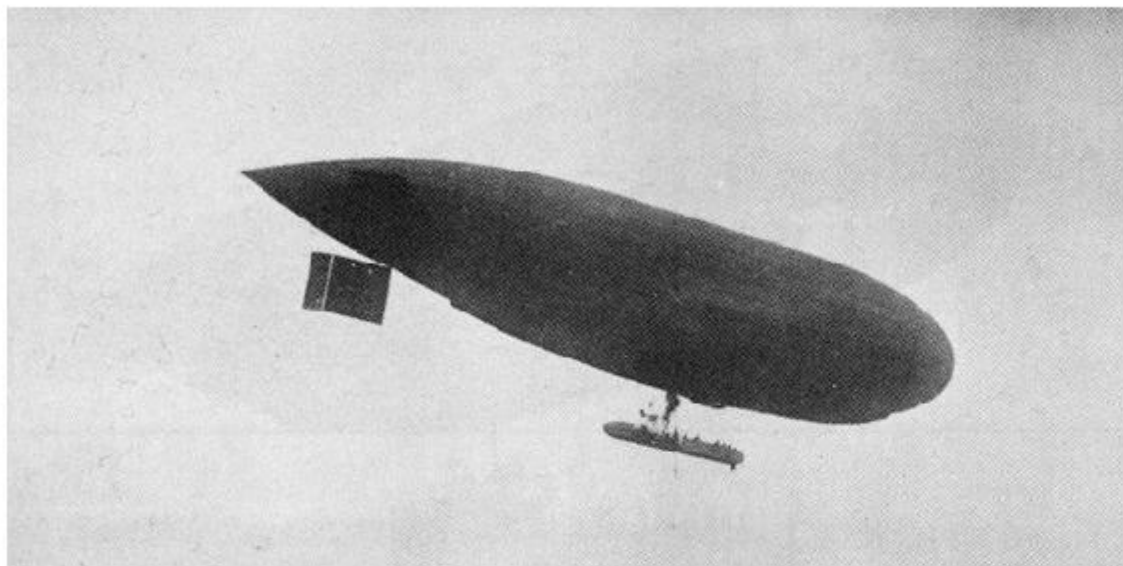

**Maximum length**, 259 feet (79 m.) **maximum diameter**, 49¾ feet (15.20 m.) **volume**, 300,750 c. feet (8,800 m<sup>3</sup>.)

**Total lift.**—

**Gas bags.**—

**Motors.**—2 N.A.G. of 110 h.p. each=220 total.

**Speed.**—33½ m.p.h.=54 k.p.h. (15 m. per sec.)

**Propellers.**—2 Parseval.

**Steering.**—Usual.

*Remarks.*—Built 1911. Station: Wanne.

### PARSEVAL P.L. 16 = P. IV. Military. (1913.)

Completing.

**Maximum length**, 308½ feet (94 m.) **maximum diameter**, 51½ feet (15.50 m.) **volume**, 353,000 c. feet (10,000 m<sup>3</sup>.)

**Gas bags.**—Metzler.

**Motors.**—2 Maybach, of 180 each=360 h.p.

**Speed.**—45 m.p.h.=72 k.p.h. (20 m. per sec.)

**Propellers.**—Two 4-bladed, wooden (on trial).

*Remarks.*—For the Prussian Army. Station: Berlin.

### RUTHENBERG II. (1911).

H. Ruthenberg, Lehderstrasse 16/19, Weissensee bei Berlin: also Luftfahrzeug-Ges, Ruthenberg, Krefeld.

Small ships on Parseval lines. Still existing, but stored away.

**Maximum length**, 151 feet (46 m.) **diameter**, 24¼ feet 7.40 (m.) **volume**, 60,000 c. feet (1,700 m<sup>3</sup>.)

**Gas bags.**—

**Motor.**—

**Speed.**—

**Propellers.**—2 Ruthenberg.

*Remarks.*—

### RUTHENBERG III. (1913).

Building.

**Length**, feet (m.) **diameter**, feet (m.) **volume**, 95,000 c. feet (2,700 m<sup>3</sup>)

**Gas bags.**—

**Motor.**—

**Speed.**—

**Propeller.**—Ruthenberg.

**Remarks.**—

**SUCHARD. Non-rigid (Trans-Atlantic). (Re-constructed 1912).**

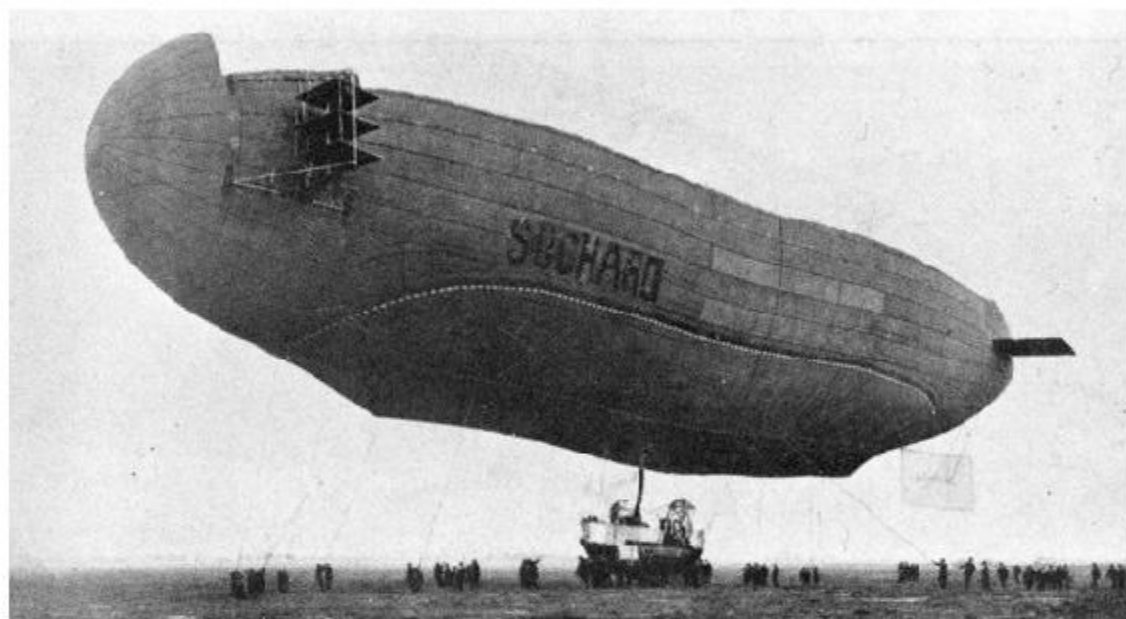

**Maximum length,** 198½ feet (60/5 m.) **maximum diameter,** 56¼ feet (17.11 m.) **volume,** 237,681 cubic feet (6,730 m<sup>3</sup>.)

**Total weight.**—About 2 tons (2,130 kgs.)

**Gas bags.**—Metzeler fabric. One ballonet.

**Motors.**—2 of 100 h.p. (one a N.A.G., the other an Escher). Placed one behind the other. A 4 h.p. motor carried for auxiliary purposes. Petrol carried, (1700 kil.) Oil, (300 kil.)

**Speed.**—17 m.p.h. (28 k.p.h.)

**Propellers.**—Two 2-bladed Zeise. Diameter, 9¾ feet (3 m.) Chain driven.

**Steering.**—Elevation by moving weight slung on cable under body. Rudder aft.

**Remarks.**—Built March, 1911, with a view to crossing the Atlantic from the Canaries to the Antilles. Re-constructed 1912. Proposed further re-construction in 1913.

**SCHÜTTE-LANZ 1. Military. S.L. I.**

(1911.) H. Heinrich Lanz, Rheinau bei Mannheim.

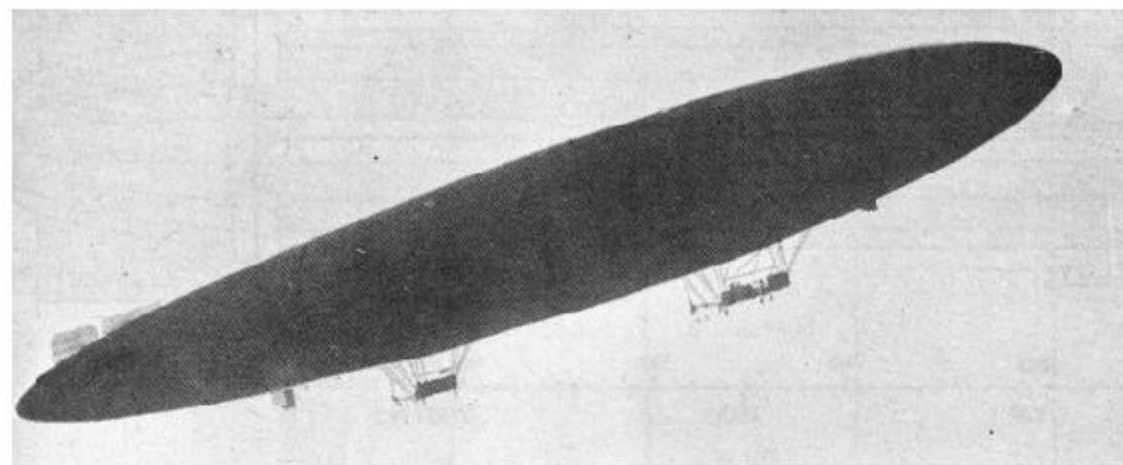

**Maximum length,** 426 feet (130 m.) **maximum diameter,** 60½ feet (18.40 m.) **volume,** 706,000 c. feet (20,000 m<sup>3</sup>.)

**Total lift.**—About 20 tons (20,000 kgs.) **Useful lift.**—About 5 tons (5,000 kgs.)

**Gas bags.**—These are of great strength and of unusual shapes, made to fit the interior, which is encumbered with cross stays. All but two of the bags are always full, and when the gas expands it flows into the remaining two, which are nearly empty at sea level, and full at 6500 feet (2,000 m.) A centrifugal pump is used for distributing the gas. There are 14 gas bags.

**Motors.**—2 Maybach of 270 h.p. each. The propellers are at the ends of the car, driven through 1 set of reduction gear. **Speed.**—38-43 m.p.h. About 59-64 k.p.h.

**Propellers.**—2 aft. Also 1 with its axis vertical.

**Steering.**—Vertical and horizontal rudders at both ends of the ship. Also see Propellers.

**Remarks.**—Two of these ships were under construction, and one was to be presented and one sold to the German government. The hull is built of special 3-ply wood made of Russian white fir; this wood is pressed into channel bars, angle bars, and all other requisite shapes. The strength of the hull is such that it can be supported at the ends without damage; its lightness is such that although the ship is nearly half as large again as *Zeppelin II*, yet the hull weighs about 3 tons less. Designed by Prof. Schütte.

In 1910, structural defects were found in *Schütte I* when the loads were applied. This has necessitated extensive alterations and much delay. In 1911 it was completed, and sold for £25,000 to the German Army.

SCHÜTTE-LANZ 2. Military. S.L. II. (1913.)

Building. Enlarged edition of above. 918,000 c. feet (26,000 m<sup>3</sup>.)]

**ZEPPELIN type. Rigid.**

Graf von Zeppelin, Friedrichshafen.

The features of this type are—A rigid framework of aluminium, a number of drum-shaped gas bags, and a thin outer cover.

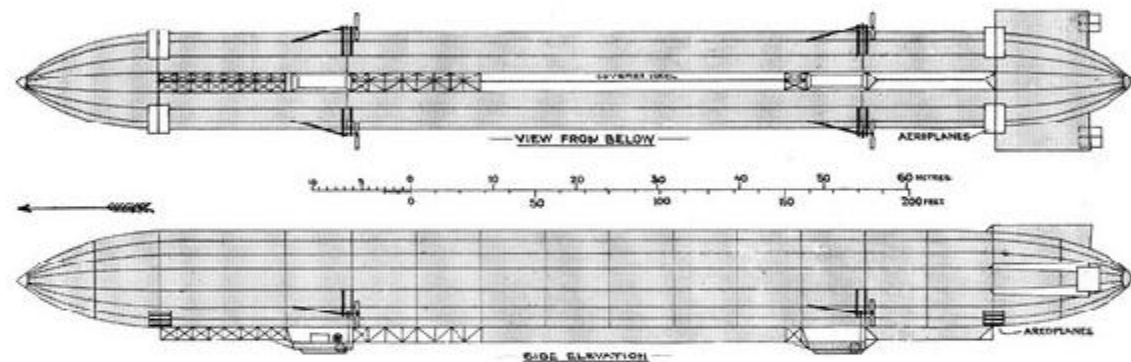

At the end of March, 1913, the total of *Zeppelins*, limit and building was 16, including one (number 18) for Austria. Of these several had come to grief in various ways, and the actual total at the date mentioned, was:—

**8 effective** = 4 Army (of which one Z4 was still on trials), 1 naval and 3 private.

3 completing or building = 1 naval, 1 private and 1 for Austria.

Others projected but not actually in hand.

All are on the lines of the above plan, differing only in minor details, such as the provision of a cabin amidships, etc., and in dimensions.

Details see the following pages.

Name	Z I.	<i>Ersatz.</i> <b>DEUTSCHLAND.</b>	Z II.	VICT. LUISE.	<b>Z III. (ex Schwaben)</b>	HA
<b>Zeppelin No.</b>	3b.	6a.	9b.	11.	12.	1
Date	1908.	1910.	1911.	1912.	1912.	1
Service	Army.	"Delag."	Army.	"Delag."	Army.	"D
Volume	c. feet (m <sup>3</sup> .)	424,000 12,000	682,000 19,000	635,000 18,000	667,000 18,700	66 18
Length	feet (m.)	446 (136)	479 (136)	459 (140)	485-1/2 (148)	48 (
Diameter	feet (m.)	38-1/2 (11.66)	46 (14)	46 (14)	46 (14)	46
Envelope		Pegamoid	...	...	...	
Gas Bags	fabric number	Continental 17	Continental 16	...	Continental 16	
Lift	total tons useful tons	12-1/2 3-1/2	16-1/2 5	17 4-1/2	19 ...	17 4-1/2
Motors	h.p.	2--85 Daimler (= 170)	3--115 Daimler (= 345)	3--120 Maybach (= 360)	3--150 Maybach (= 450)	3--150 Maybach (= 450)
Propellers	number blades	4 2	4 2	4 2	4 2	4 2
	diam feet (m.)	...	12 (3.60)	...	...	...
Max. Speed	m.p.h. (km.)	29 (46)	36 (57.5)	35 (56)	40 (62)	49 (79)
Full speed endurance	hrs.	15	20	20	40	25
Complement		...	...	...	8 crew, 25 passengers	...
Station		Metz	Oos	Cologne	Wechselnd	Cologne

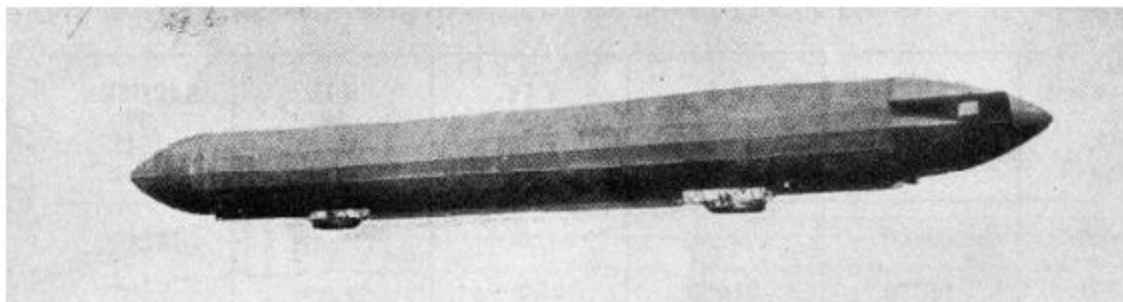

**Z1 Military.** (1908.) *Obsolete.* Shortly to be struck off list.

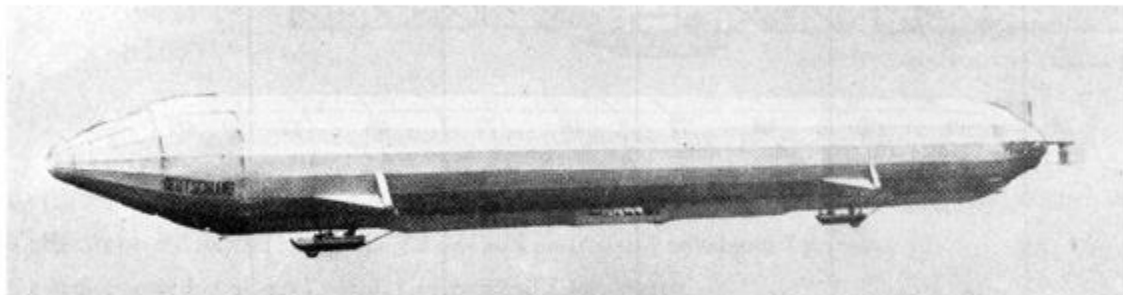

**ERSATZ DEUTSCHLAND.** (Private.) (1910.)

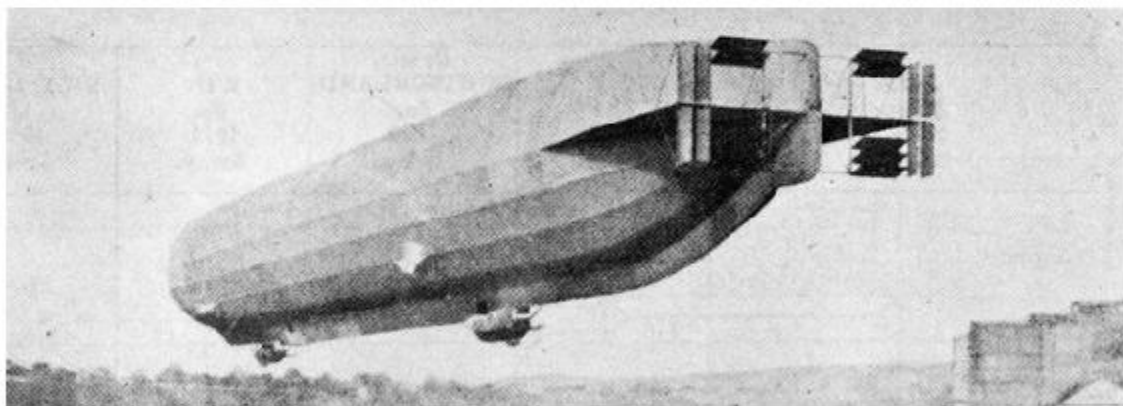

**Z II. Military.** (1911.)



**VICTORIA LUISE.** (Private.) (1912.)

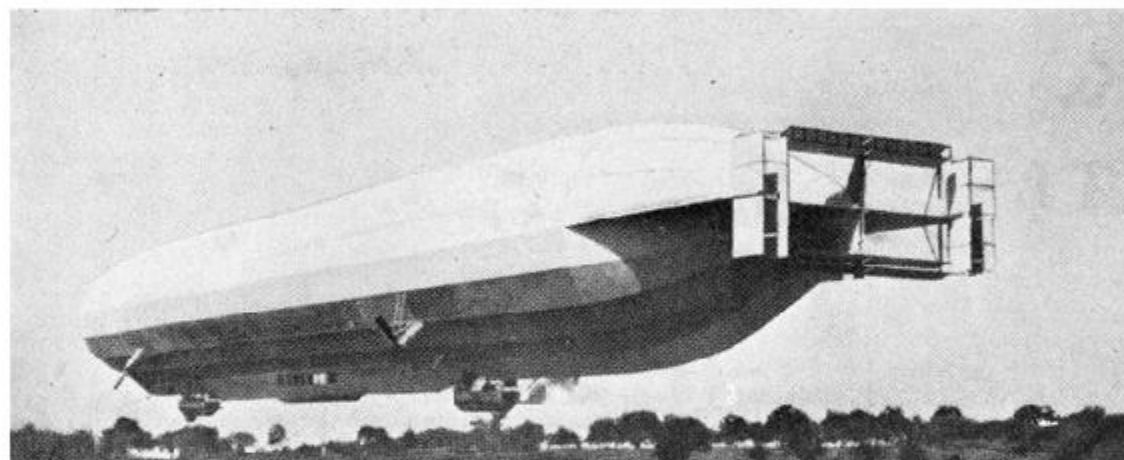

**Z III. Military.** (1912.)

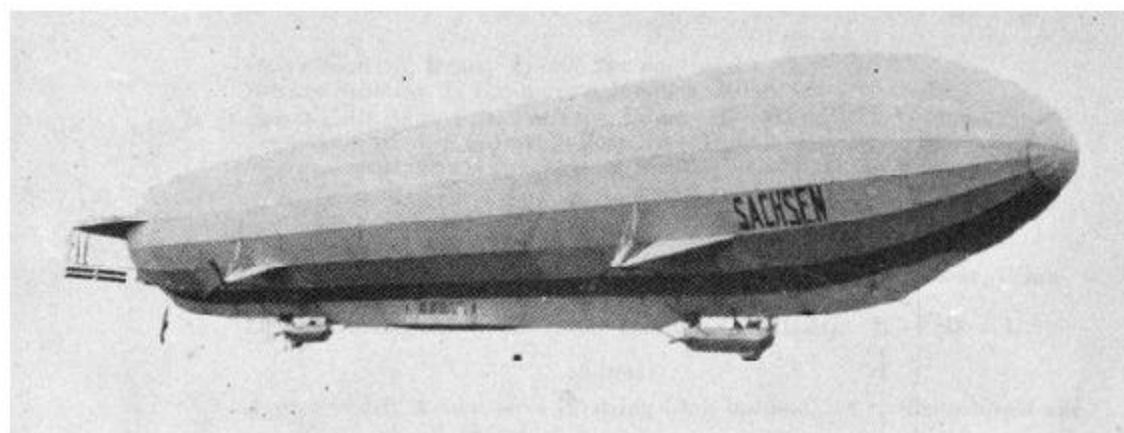

Zeppelin dirigible. Sachsen.

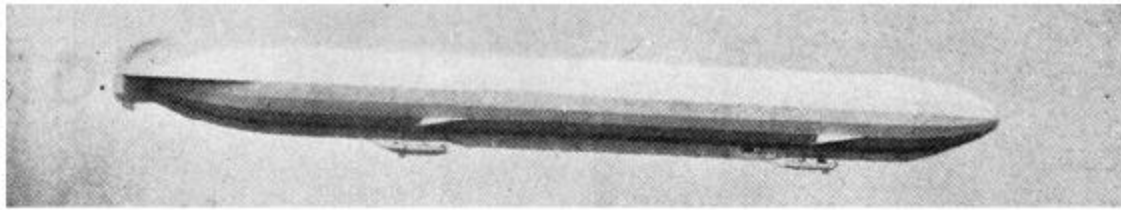

HANSA. (Private). (1912.)

No photo procurable.  
Generally resembles Z IV.

L I. Naval. (1912.) Armament: 1 gun on top.

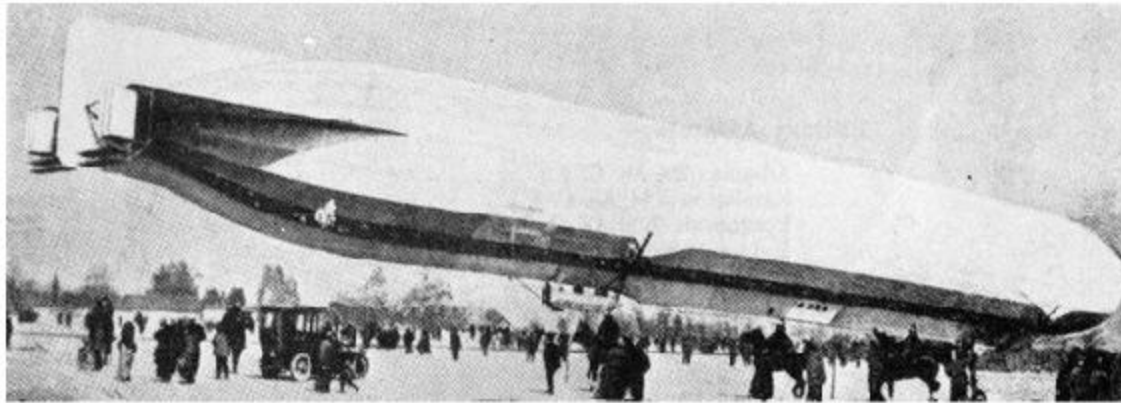

Photo. Deliius.

Z IV. Military. (1913). Armament: 1 gun on top, 1 in each gondola, 1 can be lowered from central cabin

## GREEK.

### Aerial Societies:—

None.

### Aerial Journals:—

None.

### Military Aeroplanes:—

At end of March, 1913, these included:—1 *Astra* hydro. (fitted with Scott's bomb dropper), 2 or 3 *Nieuports*, 1—100 h.p. *M. Farman*, and probably some others. Owing to the war, details are unobtainable. 3 *Bleriot*s reported captured from the Turks, and 15 *Farman*s on order.

### Military Aviators:—

Adamis (824 Ae. C. F.)  
Kamberos (744 Ae. C. F.)  
Montoussis (839 Ae. C. F.)  
Mutassas, Sub-lt., naval.  
Savoff, Lt.

### Flying Grounds:—

Phaleron.

Killed 1913.

Argyropulus, Lt.

## ITALIAN.

### Aerial Societies:—

Ae. C. d'Italia (Ae.C.I.), 62 via Colonna, Rome.

Ae. Club di Roma (Ae.C.I.), 183, via del Triton, Rome.

Circolo, Aeronautico Napoletano, 295 v. Roma, Naples.

Lega Aerea Nazionale (L.A.N.), 6 via della Signora, Milan.

Societa Aeronautica Italiana (S.A.I.),

4 via Boccaccio, Milan.

6, via Cernaia, Turin.

Societa Aviazione, di Torino (S.A.T.), 28 via Roma, Turin.

Societa Ital. di Aviazione, (S.I.A.), 14 v. Monte Napoleone, Milan.

### Aerial Journals:—

(3 times a week.)

*Gazzetta dello Sport*, 15 v. della Signora, Milan. L—.05 (=1/2d.)

(Weekly):

*Italia Sportiva*, Rome. L—.05 per no. (=1/2d.)

*Lettura Sportiva*, 17 corso Porta Romana, Milan. L—.10 (=1d.)

*Sports (Gli)*. 46 and dei Prefretti, Rome. L—.05 (=1/2d.)

*Stampa Sportiva*, 3 v. Davide Bertolotti, Turin. L—.10 (=1d.)

*Tribuna Sport*, 22 via S. Giacomo, Naples. L—.10 (=1d.)

(Monthly):

*Rivista della L.A.N.* (Lega Aerea Nazionale), Milan.

*Rivista del T.C.I.* (Touring Club Italiano), 14 v. Monte Napoleone, Milan. L—.40 (=4d.)

*La Navigazione Aerea* (Bolletino dell' Ae. C. d'Italia). L—1.80 (=1/6.)

(Annual):

*Annuario dell' Aeronautica* (Touring Club Italiano), 14 v. Monte Napoleone, Milan. L—6.00  
(=5/-)

### Flying Grounds (Military see next page):—



**Cameri**, Novara.—15 hangars (Thouvenot school).

**Mirafiore**, Turin.—17 hangars (Asteria and Chiribiri schools).

**S. Giusto**, Pisa.—4 hangars (Antoni school).

**Taliedo**, Milan.—26 hangars.

**Vizzola Ticino**.—7 hangars (Caproni school).

### Dirigible Headquarters (with hangars, etc., etc.):—

Bracciano.

Milan.

Rome.

Venice.

Verona.

## ITALIAN MILITARY AVIATION.

### ORGANISATION, etc.

The *Battaglione Aviatori* has its headquarters at Turin. In July, 1912, it was re-organised along the following lines:—

1 command at Turin.

1 flying work.

1 technical work.

2 troop duty.

6 at the aviation schools, with a certain number of mobile squadrillos.

The recognised grades are:—

*a.a.p.* aspirante allievo (learners).

*a.p.* allievo pilota (certificated pilots).

*p.* pilota militare (superior military brevet).

In flying work the superior pilots are mostly using *Bleriot*s; the ordinary pilots *Bleriot-Caproni*, *Bristol*, *Antonis*, *Deperdussins* and *Voisins*.

The technical section chiefly supervises the theoretical instruction of the *a.a.p.*

The 2 companies on troop duty practical work, preparation for the schools.

### FLYING SCHOOLS.

The military schools are:—

**Aviano**.—Central school. Size about 5×2 kilometres. Sheltered from all winds except westerly, by banks of trees. Numerous hangers.

**Mirafiori (Turin)**.—Mixed military and civil school. Hangers. School machines confined to *Asteria*, *Bleriot*, *Nieuport* and *Savary* types.

**Pordenone**.—School for superior brevets. Treeless plain. Principal school machines *Breguets* and *Farmans*; but some *Bleriot*s and *Caproni*.

**S. Francesco al Campo**.—*M. Farman* machines. At present for officers trained in France.

**Somma Lombarda**.—Camp school for *Nieuports*.

**Venaria Reale**.—Formed late in 1912. *Bristol* monos for certificated pilots.

### GENERAL TRAINING.

50 officers in training during the first quarter of 1913.

Aspirants commence with instruction in the theory of heavier than air machines, resistance of material and particular instruction in the various type of aero motors in use. They are taken for flights as passengers.

All then go to the training camp about 80% for monoplane work, the remainder for biplanes.

Monoplanes. Special attention paid to teaching *Gauchis Dessent*.

Biplanes. Much shorter course. Principal feature: *Vol Plané*.

For the *military brevet* the examination is most comprehensive, special attention is paid to flying in wind, manoeuvring, climbing, good landings without inconvenience to passengers, cross country flights, etc. The course is generally modelled on war experiences.

### TOTAL FLYING STRENGTH.

No particular distinction between naval and military aviators.

Total by end of June, 1913, to be about 225 certificated aviators of whom a fair percentage hold the superior brevet. In addition all the best civilian aviators are held at disposal.

### Military Aeroplanes.

At the end of 1911 there were about 20 machines, mostly *Bleriot*s and *Farmans*. The majority of these are still in use for school purposes.

At the end of March, 1913, the machines effective for war purposes were roughly as follows:

—

*Bleriot.* Total about 50, plus a number of school machines.

*Bristol* (mono.)

*Caproni.*

*Deperdussin.*

*Farman.*

*Hanriot.*

*Nieuport.*

*Savary.*

About 40 machines were on order, including 12 *Bristol-Capronies*.

## Naval Aeroplanes.

Effective at end of March, 1913.

1 *Calderara.*

1 *Guidoni-Farman.*

4 or 5 others.

## ITALIAN AVIATORS.

### Military.

Agostoni, Capt. V. (45)

Bailo, Lieut. (71)

\*Bolla, Capt. (89)

Cannonieri, Lieut. (22)

+Cammarotta, Lieut. (15F)

De Filippi, Com. (5)

\*De Rada, Lieut. (38)

\*Falchi, Capt. (55)

Garassini. (29)

\*Gavotti, Lieut. (25)

Gazzera, Lieut. (20)

Guidoni, Capt. (58)

\*Lampugnani, Lieut. (33)

+Manazini, Lieut. (98)

Moizo, Capt. (40)

Neri, Lieut. (345-Ae. C. F.) (106)

\*Palmadi, Cesnola Lieut. (75)

\*Piazza, Major (44)

Pizzagalli, Capt. (49)

Poggi, Lieut. (82)

Prandoni, Capt. (69)

\*Pulvirenti, Lieut. (50)

Raffaelli, Lieut. A. (108)

Ravelli (453, Ae. C. F.)

Roberti, Lieut. (47)

Rossi, Capt. (27)

+Sagheti, Lieut. (16)

Savoia, Lieut. T. U. (4)

Surdi, Lieut. (32)

\*Vece, Lieut. F. (74)

+Vivaldi, Lieut. (31)

Brevets in 1912.

Andriani, Capt. O. (137)

Antonini, Capt. L. (91)

Almerigi, F. (159)

Alvisi, Lieut. A. (172)

Baglione, Lieut. A. (129)

Baracca, F. (167)

Bonamici, L. (101)

Bongiovanni, Lieut. E. (115)

Bongiovanni, c. L. (124)

Bonuti, R. (135)

Brach, Lieut. F. (146)

Buzzi, Lieut. M. (156)

Calderara, Lieut. A. (134)

Calori, S. (136)

Capuzzo (143)

Casabella, Lieut. G. (121)

Clerici, Lieut. U. (110)

Cuzzo, Capt. A. (166)

De Giovanni, Lieut. G. (101)

De Riso, Lieut. G. (153)

Della Chiesaconte, Lieut. A. (109)

Ercole, Lieut. E. (117)

Franceschini, Lieut. E. (112)

Gallotti, Lieut. A. (150)

Garino ing. G. (134)

Girotti, Lieut. M. (100)

Gordesco, Lieut. M. (151)  
\*Graziani, Lieut. C. (92)  
Jacoponi, Lieut. A. (171)  
Kerbaker, Lieut. E. (99)  
Laureati, Lieut. G.  
Leffi dott. sott. med. A. (169)  
\*Mareno, M. A. (90)  
Moreno, Capt. G. (78)  
Nosari, G. (142)  
\*Novellis di Coarazze, Capt. A. (94)  
Oddo, A. (147)  
Pagano, P. (158)  
Palpacelli, A. (164)  
Perrucca, D. (162)  
Poggioli, Q. (107)  
Pongelli, R. (60)  
Porta, Capt. E. (145)  
Prandoni, Capt. E. (69)  
Resio, Lieut. (120)  
Rosetti, A. (157)  
Russi, Lieut. S. (152)  
Suglia, Lieut. C. (118)  
Torelli, F. (165)  
Valdimiro, Lieut. F. (170)  
Venanzi, U. (155)  
Zanuso, Lieut. G. (149)

## Naval.

*(To end of 1911).*

Calderara, Lieut. (1)  
Ginnochio, Lieut. (18)  
\*Rossi, Sub. Lieut. (31)  
Strobin, Lieut. (39)

*(During 1912).*

De Muro, Lieut. (119)  
Frigerio, Lieut. (154)  
Scelsi, Capt. difreg. G.

## Private.

*(To end of 1911).*

Akachew, C. (61)  
Amerigo (3)  
Barigiola, G. (51)  
Battagli, B. (34)  
Bianchi, P. (6)  
Biego, C. (56)  
Bigliani, A. (63)  
Borgotti, G. (43)  
Brilli, D. G. (48)  
Brociner, M. (87)  
Cagno, U. (10)  
Cagliani, A. (23)  
Cannoniere, Umberto (22)  
Cattaneo, Bartelomo (2)  
Cavaglia, Pietro (30)  
Cavalieri, Alfredo (17)  
Cei, J. (53, Ae. C. F.)  
Casaroni, A. (77)  
+Cirri, Ciro (11)  
Cobianchi, Mariot (24)  
Darioli, Ernesto (9)  
Da Zara, Leonino (7)  
De Agostina, A. (53)  
De Antonis, A. (67)  
Faccioli, Mario (21)  
Franzoni, R. (62)  
Garassini, G. G. (29)  
Gianfelice (59)  
Ginnochio, T. (18)  
Graziani, nob. Ettore (28)  
Lusetti, A. (19)  
Maffeis, C. (36)  
Maggiore, C. (72)  
Manissero, R. (37)  
+Marra, R. (35)  
Marro, E. (52)  
Mogafico, Mario (26)  
Mosca, Francesco (47)  
Pasquali, R. (66)

Piccolo, G. (32)  
Poggioli, Quinto (117)  
Porro, A. (113)  
Ramasotto, M. M. (148)  
Ravetto, Clemento (12)  
Ré, Umberto (86)  
Ruggerone, G. (14)  
Sabelli, G. (93)  
Santoni, L. (114)  
Stucchi, Federico (8)  
Verona, A. (54)

*(Brevets in 1912).*

Amour, ing. E.  
Arista, A. (131)  
Ballerini, M. (132)  
Bergonzi, P. C. (78)  
Berni, L. (95)  
+Bertoletti, R. (79)  
Borsalino, G. M. (102)  
Brunetta D'Usseaux, G. (125)  
Carabelli, C. (104)  
+Caramanlaki, A. (97)  
Caramanlaki, G. (168)  
Carminati di, B. N. (163)  
Colucci, G. (80)  
Corsini, J. C. (133)  
Corsini, A. E. (85)  
Dalla, N. C. (126)  
Dal Mistro, C. A. (127)  
De Campo conte, S. (103)  
Fabri, A. (165)  
Facchini, E. (141)  
Garino, G. (134)  
Gelmetti, A. (83)  
Grassi, conte A. (88)  
Leonardi, G. (122)  
Mandelli, P. (96)  
Marazzi, E. (140)  
Nardini, G. (128)  
Paolucci, G. (144)  
Piceller, G. (105)

Sacerdoti, C. (116)  
Salengo, R. (138)  
Vallet, C. (86)  
Zorra, L. (84)

### **Private Aeroplanes.**

At the end of March, 1913, there were about 45 machines in use at the various private schools, and about 6 privately owned aeroplanes.

# ITALIAN AEROPLANES

## A

### ANTONI.

Soc. di aviazione Antoni, via Vitt. Emanuele, 46, Pisa. School: S. Guisto, Pisa. Output capacity: about 20 machines a year.

		1912-13. Single seat mono.	1912-13. 2-seater military mono.
Length	feet (m.)	33 (10)	36 (11)
Span	feet (m.)	28 (8.50)	28 (8.50)
Area	sq. feet (m <sup>2</sup> .)	172 (16)	237 (22)
Weight	machine lbs.	660 (300)	770 (350)
	(kg.)		
	useful lbs. (kg.)	...	...
Motor	h.p.	Gnome or Anzani	Gnome and Anzani
Speed	max. m.p.h. (km.)	...	...
	min. m.p.h. (km.)	...	...
Endurance	hrs.	...	...
Number built during 1912		...	...

### ASTERIA.

Fabbr. Ital. Aeroplani ing. Darbesio e. C., via Salbertrand, 12, Torino (Turin). School: Mirafiori. Capacity: small.

		1912-13. Monoplane.	1912-13. Biplane.
Length	feet (m.)	21-3/4 (6.50)	29-1/2 (9)
Span	feet (m.)	26-1/2 (8.10)	44 (13.50)
		...	24-1/2 (7.50)
Area	sq. feet (m <sup>2</sup> .)	162 (15)	431 (40)
Weight	machine lbs. (kgs.)	530 (240)	110 (500)
	useful lbs. (kgs.)	...	...
Motor	h.p.	50 Gnome	70 Renault
Speed	max. m.p.h. (km.)	...	...
	min. m.p.h. (km.)	...	...
Endurance	hrs.	...	...
Number built during 1912		...	...

## C

### CALDERARA. Navy hydro-monoplane.

Model 1912-13.		"Hydro vol."
Length	feet (m.)	54 (16.50)
Span	feet (m.)	61 (18.50)
Area	sq. feet (m <sup>2</sup> .)	753 (70)
Weight	total lbs. (kgs.)	2644 (1200)
	useful lbs. (kgs.)	...
Motor	h.p.	150 (formerly 100 Gnome)
Speed	max. m.p.h. (km.)	62 (100)
	min. m.p.h. (km.)	50 (80)
Endurance	hrs.	6-1/2
Number Built during 1912		1

Lieut. Calderara's floats consist of a plurality of w.t. compartments with internal lattice frame, well braced. Hull is formed of three skins of wood, sail-cloth between each. Distance between outer floats, 21 feet (6.30 m.) Centre of gravity is only 4½ feet (1.40 m.) above water. If necessary wings can be cut away and the central hull used as a boat with emergency sail.

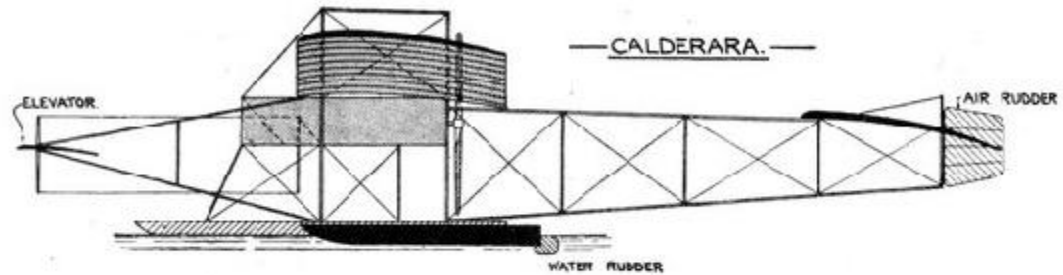
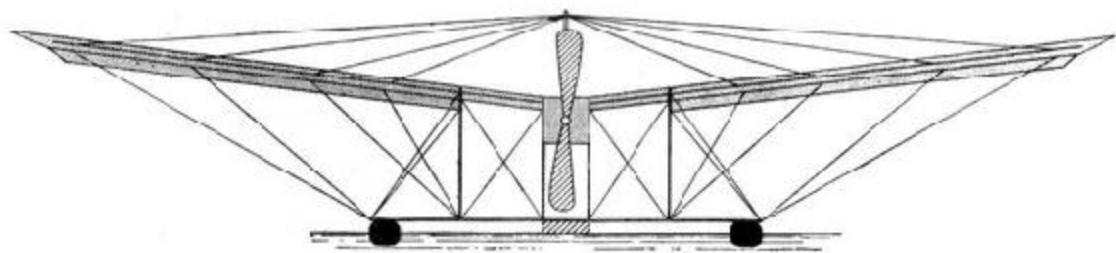

CALDERARA. Uniform Aeroplane Scale

## CAPRONI.

Soc. di Aviazione Ingg, Caproni e Faccanoni, Vizzola Ticino. School: Vizzola Ticino.

Models 1912-13.		Single Seat mono. A.	Single Seat mono. B.	2-seater mono.	3-seater mono.
Length	feet (m.)	26-1/4 (8)	26-1/4 (8)	...	...
Span	feet (m.)	29 (8.80)	29 (8.80)	...	...
Area	sq. ft. (m <sup>2</sup> .)	162 (15)	162 (15)	172 (16)	226 (21)
Weight	machine lbs.	485 (220)	660 (300)	750 (340)	760 (345)
	useful lbs. (kgs.)	...	...	...	...
Motor	h.p.	35 Anzani	50 Gnome	60 Anzani	80 Gnome
Speed	max. m.p.h. (km.)	56 (90)	75 (120)	75 (120)	87 (140)

	min. m.p.h. (km.)	...	...	...	...
Endurance	hrs.	3-1/2	...	...	4
Number built during 1912		...	...	...	...

Remarks.—At the end of 1912, held Italian record for speed, 200-300 k.m. Flown by Cobioni.

## CAPRONI-BRISTOL.

Caproni also builds under Bristol license.

## CHIRIBIRI.

A Chiribiri e. C, via Lamarmora 28, and via Don Bosco 68-73. Torino (Turin).

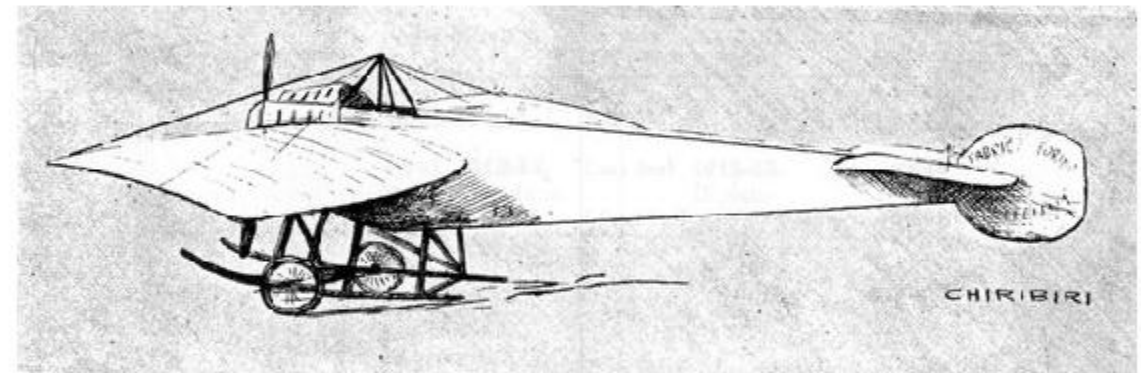

CHIRIBIRI.

Models 1912-13.		45 h.p. mono.	50 h.p. mono.	Racing mono.	80 h.p. mono.
Length	feet (m.)	23 (7)	23 (7)	24-3/4 (7.50)	25-3/4 (7.80)
Span	feet (m.)	29-1/2 (9)	29-1/2 (9)	31 (9.30)	39-2/3 (12.10)
Area	sq. ft. (m <sup>2</sup> .)	204 (19)	204 (19)	226 (21)	258 (24)
Weight	machine lbs. (kgs.)	595 (270)	683 (310)	772 (350)	595 (270)
	useful lbs. (kgs.)	...	...	...	...
Motor	h.p.	45 Chiribiri	50 Chiribiri	60 Chiribiri	80 Chiribiri
Speed	max. m.p.h. (km.)	44 (70)	56 (90)	103 (165)	65 (105)
	min. m.p.h. (km.)	...	...	...	...
Endurance	hrs.	...	...	...	...
Number built during 1912		...	...	2	...

## F

### FRIULI.

E. Pensuti e E. Calligaro, Pordenone. School: Pordenone. A 30-35 h.p. Anzani motor mono-plane. Area, 150 sq. feet. (14 m<sup>2</sup>). Generally of *Bleriot* type, but *Hanriot* type landing carriage.

## G

### GUIDONI. Naval Hydroavions.

Either a *Farman* biplane or a *Nieuport* mono. is used, mounted on special floats designed by Capitano del Genio navale Guidoni. There are two long floats, each of which is fitted with parallel fins.

## FOREIGN AGENCIES.

Foreign types of machines are constructed in Italy under licenses as follows:—

### BLERIOT.

Soc. Ital. Transaerea, corso Peschiera 25, Torino (Turin).

### BRISTOL.

(British), by Caproni.

### DEPERDUSSIN.

Soc. Ital. degli Aeroplani, via Giulini 7b, Milan.

### NIEUPORT.

Carrozzeria Macchi. Varese.

# ITALIAN DIRIGIBLES.

Notes: All the above are semi-rigid. The *P* and *M* are all of the same general type. Principal features of these ships, which were designed by Captains Crocci and Ricaldoni, are the shape of the envelope, (maximum diameter very far forward), keel and the box kite tail. The *Citta di Milano* (semi-rigid) is an enlarged *Leonardo da Vinci* (which see). *Special feature* is the keel built into the envelope. This serves as a nacelle.

Name and Date.	Army.					Navy.	
	P1. 1909.	P2 & P3. 1910 & 1911.	P4 & P5. both 1912.	Citta di Milano 1912.	Parseval. (P.L. 17). 1912-13.	M1. 1912.	M2 & M3. 1912 & 1913.
Volume	c. feet (m <sup>3</sup> .)	148,000 (4200)	155,000 (4400)	166,000 (4700)	424,000 (12000)	353,000 (10000)	424,000 (12000)
Length	feet (m.)	197 (60)	207 (63)	207 (63)	233 (72)	279 (85)	272-1/3 (83)
Diameter	feet (m.)	38 (11.60)	38 (11.60)	39-1/3 (12)	59 (18)	52-1/2 (16)	56 (17)
Gas bags	fabric compartments	Silk 7	Continental 8	Continental 8	...	Riedinger 0	Metzeler 0
	ballonets	1	1	1	...	2	...
Lift	total tons	3.50	3.50	3.75	...	...	9.50
	useful tons	1.10	1.35	1.50	...	3.00	3.80
Motor	h.p.	1-100 C. Bayard (=100)	1-120 C. Bayard (=120)	2-80 Fiat (=160)	2-85/100 Isotta (=170/200)	2-170 Maybach (=340)	2-250 Fiat (=500)
Propellers	number	2	2	2	2	2	2
	blades	2	2	2	3	4	4
	diameter feet (m.)	10 (3)	10 (3)	10 (3)	14 (4.20)	...	12-1/2 (3.80)
Max. speed	m.p.h. (km.)	32 (52)	35 (56)	37 (60)	45 (72)	40 (65)	44 (70)
Full speed endurance	hrs.	...	...	...	...	20	12
Max. complement		5	5	5	...	...	14
Station		Bracciano	Tripoli	Vigna di Valle	Baggio	Venice	Bracciano

## Army Dirigible Pilots.

## Navy Dirigible Pilots.



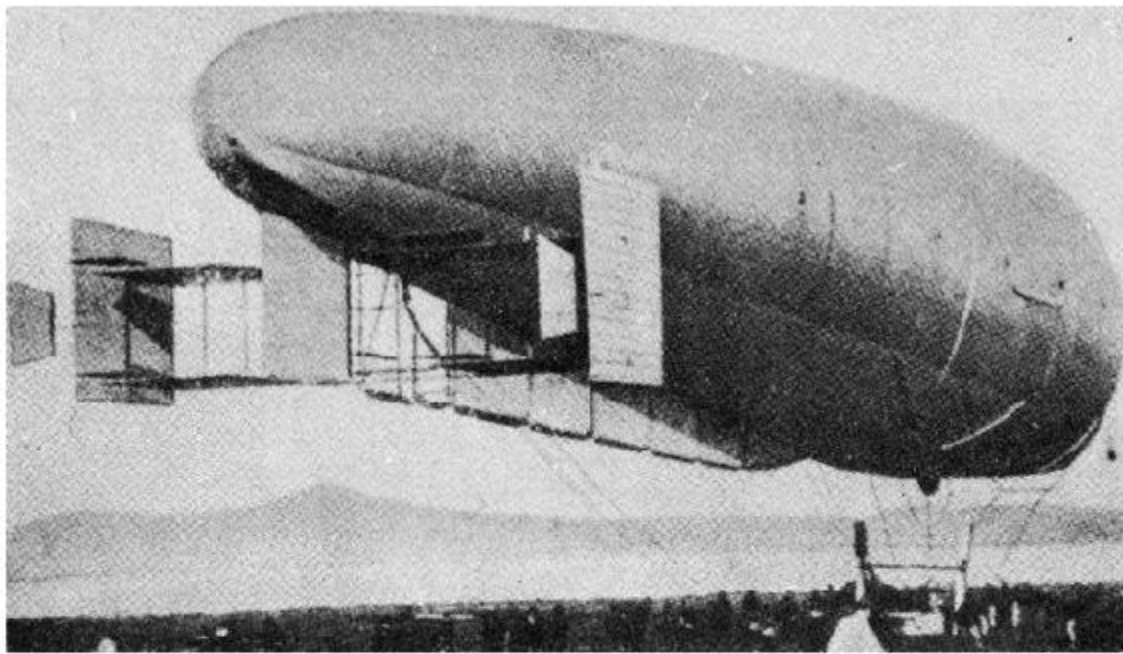

P.I.

Elevation of P. I. The later ships only differ in dimensions, and the fact that the middle rudder is done away with.

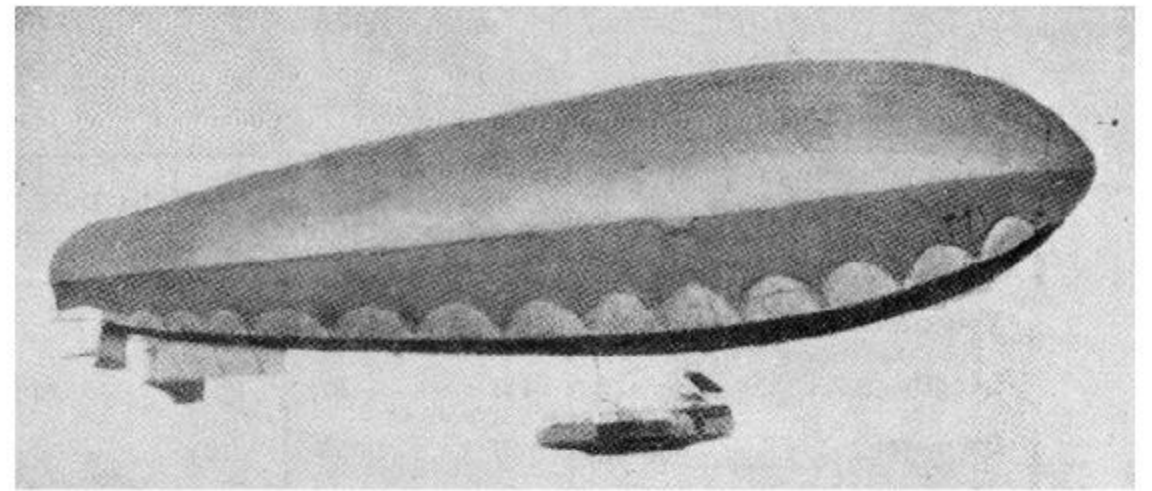
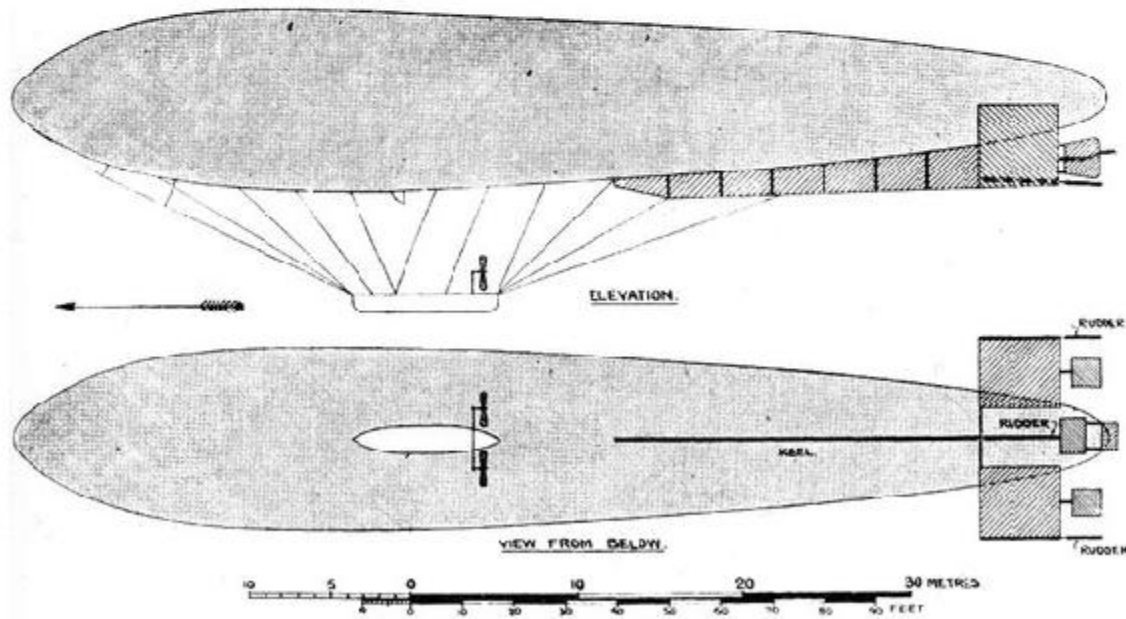

Dirigibles M1 & M2.

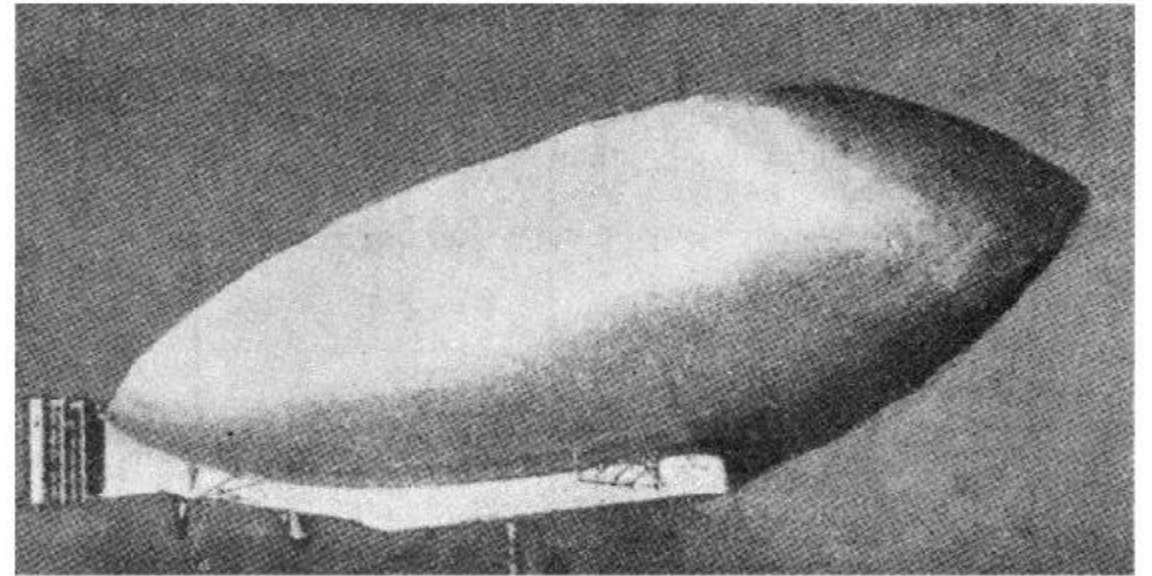

Citta di Milano.

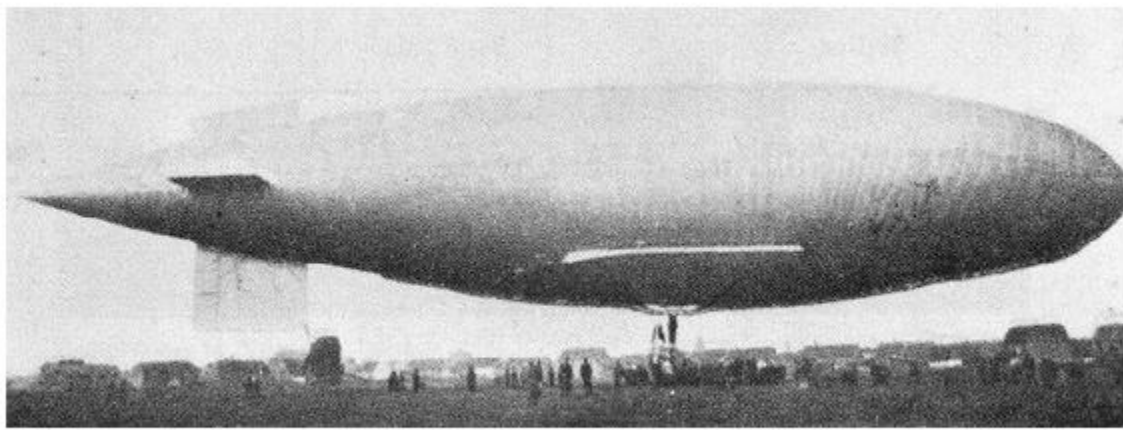

Parseval (P.L. 17). First Italian *Parseval*.

#### ITALIAN PRIVATE DIRIGIBLES.

Name and date.		<b>Ausonia bis.</b> Reconstructed 1910.	<b>Italia I.</b> 1905.	<b>Italia II.</b> 1913.	<b>Leonardo da Vinci.</b> 1909.	<b>Usuelli.</b> 1909.
Volume	(m <sup>3</sup> .)	(1500)	(1500)	(2600)	(3265)	(3870)
Length	feet (m.)	121 (37)	128 (39)	164 (50)	131-1/4 (40)	167-1/3 (51)
Diameter	feet (m.)	27 (8.25)	19-3/4 (6)	32-3/4 (10)	46 (14)	32 (9.80)
Gas bags	fabric	...	...	...	...	...
	compartments	nil.	nil.	nil.	7	6
	ballonets	1	nil.	nil.	1	1
Lift	total tons	...	1.35	2.20	3.00	...
	useful tons	0.80	...	...	...	...
Motor	h.p.	1-55 h.p. S.P.A.	1-40/50 Antoinette	1-50 h.p.	1-40 Antoinette	1-80 h.p. S.P.A.
Propellers	number	1	1	2	2	2
	blades	2	2	2	5	2
	diameter, feet (m.)	10-3/4 (3.20)	15 (4.50)	10 (3)	9 (2.70)	...
Max. speed	m.p.h (k.m.)	25 (40)	25 (40)	...	...	30 (50)

Full speed endurance	hrs.	...	...	...	...	6
Max. complement		...	...	...	...	...
Station		Bosco Mantico	Schio	building	Laid up at Baggio near Milan	Turin

#### Notes:

**Ausonia.** Nico Piccoli, via Accademia 12, Padova (Padua). Works: Magré, Vicenza (Schio). Semi-rigid.

**Italia.** Cont Almerico da Schio, Schio. Non-rigid. *Special features* is a "belly" of Para rubber in lieu of a ballonet.

**Leonardo da Vinci.** Ing. Enrico Forlanini, via Boccaccio 21, Milan. Works: Baggio. Semi-rigid, keel and nacelle, incorporated in envelope.

**Usuelli.** Usuelli and Borsalini, Torino (Turin). Non-rigid.

#### Private Dirigible Pilots.

Forlanini, ing. E.

Piccoli, D.

Usuelli, C.

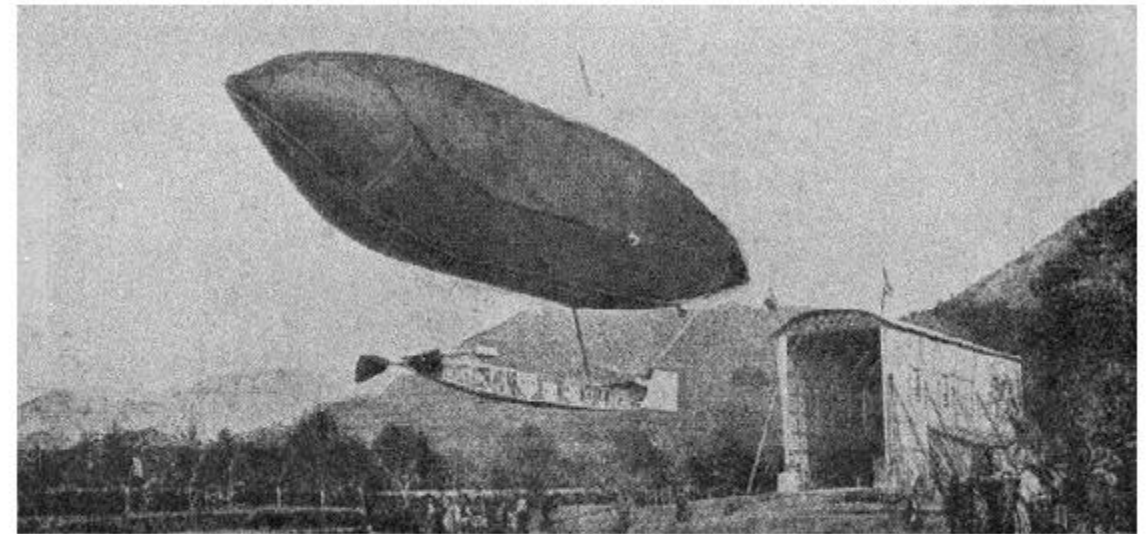

Italia.

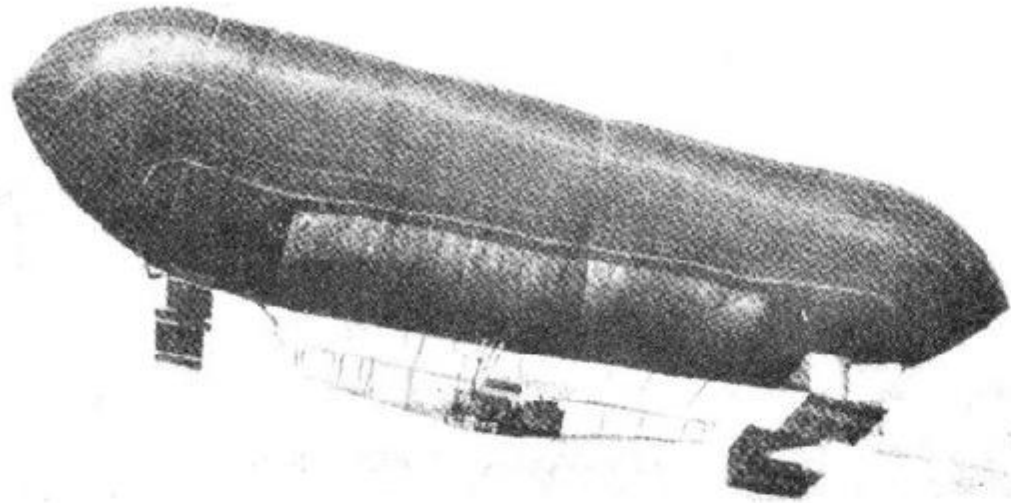

Uselli.

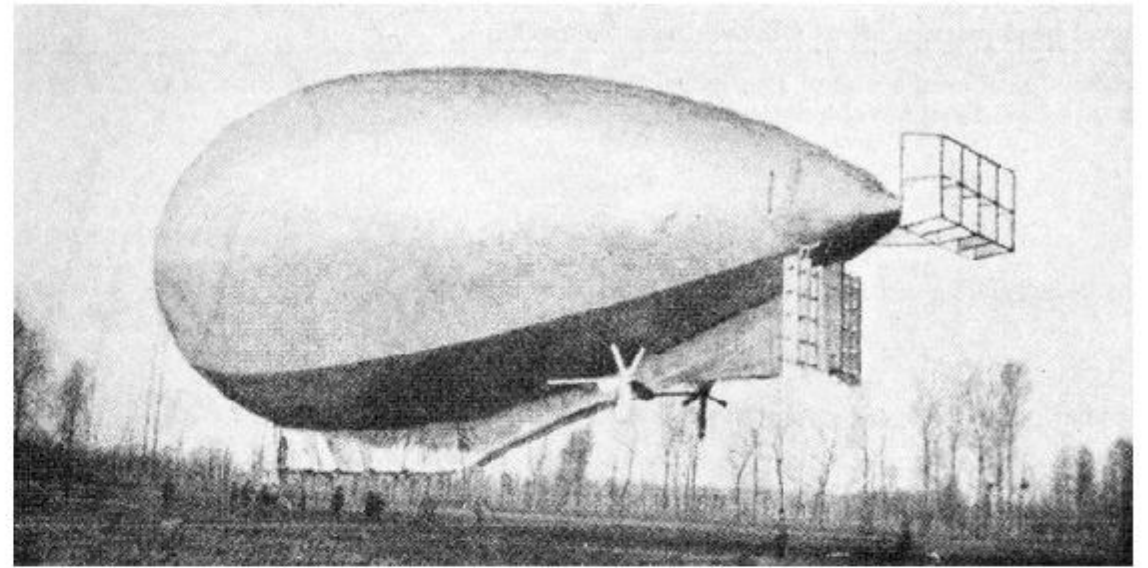

Leonardo da Vinci.

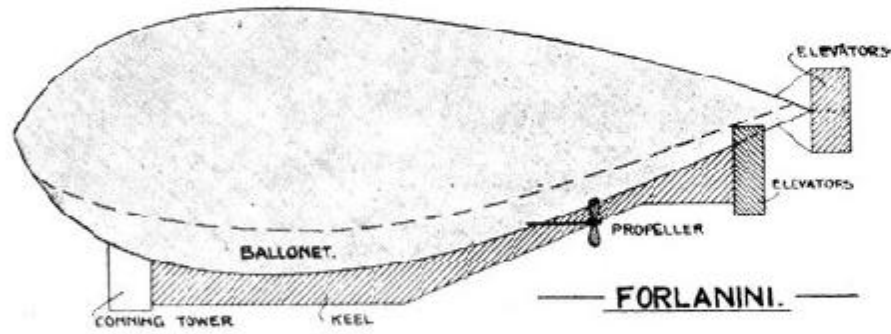

FORLANINI. Uniform Dirigible Scale.

## JAPANESE.

(Naval Aviation data. Official).

### Aerial Societies:—

Tokio, Ae. Co.  
Aeroplane Assoc., 1, Yayesu Cho, I-Chome, Kojimachi, Tokio. (Sec.: Dr. Fujioka).  
Kikyū Kinkyū Kai (connected with War Office).

### Flying Grounds:—

Near **Yokohama**.  
**Saitama**, Tokorozawa (Government).—Dirigible shed and hangars.  
**Port Arthur**, (Government).

### General Military Aviation.

This was originally formed as one body without distinction between army and navy. It was subsequently re-modelled on lines somewhat similar to the British Royal Flying Corps with naval and military wings.

### Navy.

The naval section is superintended by Capt. K. Yamaji, I.J.N.  
The naval headquarters are at Oihama (near Yokosuka).  
The naval force at the end of 1912 consisted of 4 hydro-aeroplanes (2 *Curtiss* and 2 *Farman*).  
The available total of qualified naval aviators was 5.

### Finance.

The total amount granted for aviation of the navy in 1912 (fiscal year) was 100,000 yen (£10,000).  
For the year 1913 the estimates amount was 100,000 yen (but not approved yet).

### Pay of Flying Officers.

The special pay for officers employed in aerial work is undecided.

### Army.

The army wing is responsible for the dirigible. Aeroplanes are one or two *Bleriot*s, a *Grade*, 2 *Tokogawa*, and a *Farman*.

### AVIATORS.

#### Military.

Hino, Major  
Saigom, Capt.  
Tokogawa, Capt.  
Tokogama, Lieut.

#### Naval.

Narahara, Naval Constr.  
Kaneko, Lieut.  
Kono, Lieut.  
Obama, Eng. Lieut.  
Umikita, Lieut.  
Usuioku, Naval Constr.

#### Private.

Doig, S.  
Iga, Baron  
Shigeno, Baron  
Tsuzuki,  
Yamada, Isaburo

The following have been killed:—

1912.  
Aibata, Lieut.

1913.  
Kimura, Lieut.  
Tokuda, Lieut.  
Takeishi.

## Private Aviation.

There are some private aeroplanes being regularly flown in Japan. A number of aeroplanes have from time to time been invented by naval and military officers and private individuals, and some of them are in use. Inventors include Major Hino, naval constructor Narahara and Ushioki, Baron Iga, Baron Shigeno and Mr. Tsuzuki.

## JAPANESE AEROPLANES.

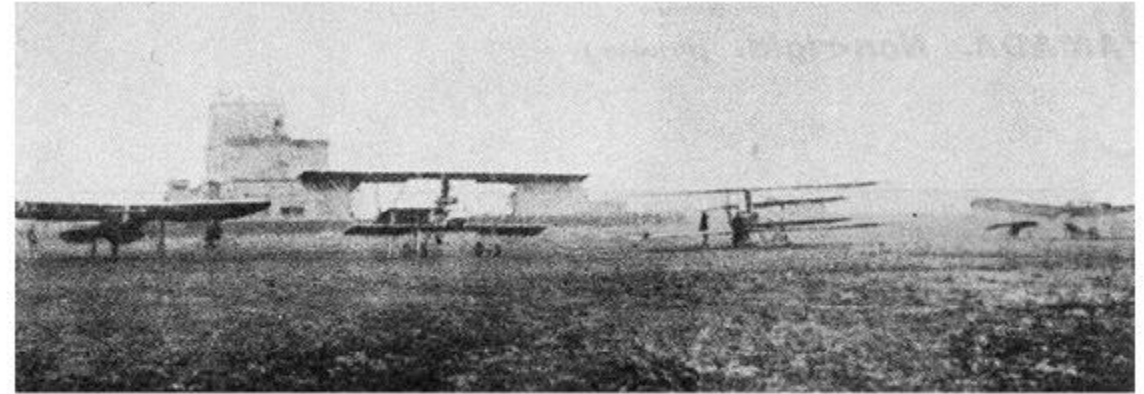

Bleriot (since wrecked). Tokogawa. Wright. Grade. Army Flying School ground.

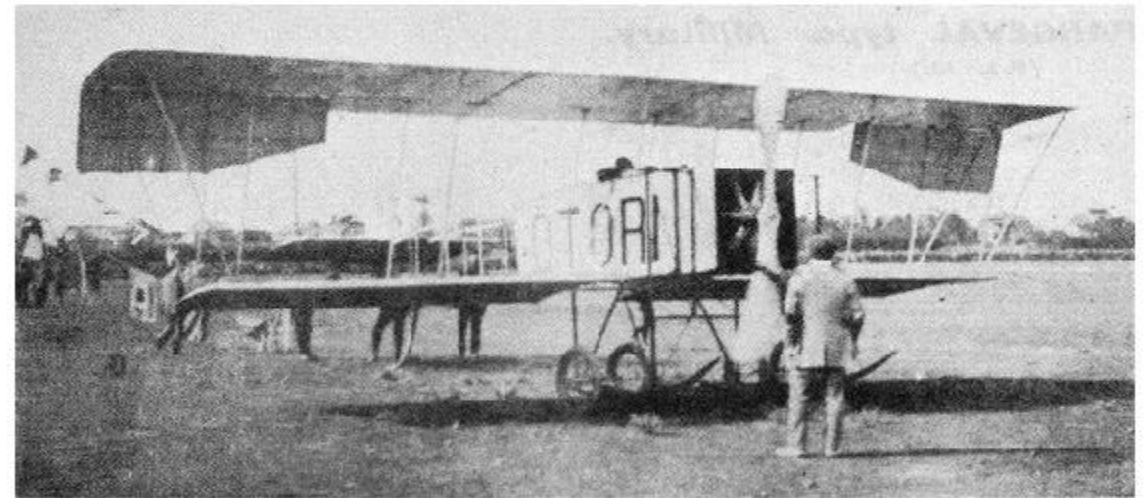

Narahara.



Tokogawa II. Type I the same except for minor details.

## JAPANESE DIRIGIBLES.

**PARSEVAL type. Military.**

(P.L. 13.)



**Length** 259 feet (19 m.) **maximum diameter** 47¾ feet (14.50 m.) **capacity**, 8,500 m<sup>3</sup>.

**Gas bag.**—2 ballonets. Usual Parseval.

**Motors.**—Total, 300 h.p., made up of two 150 h.p. Maybach.

**Speed.**—42 m.p.h. (65 km.)

**Propellers.**—Two 4-bladed. Parseval.

**Steering.**—Usual Parseval (see German).

**Remarks.**—Of Parseval P.L. 12 type (see German). Built 1911.

**YAMADA. Non-rigid. (Private.)**

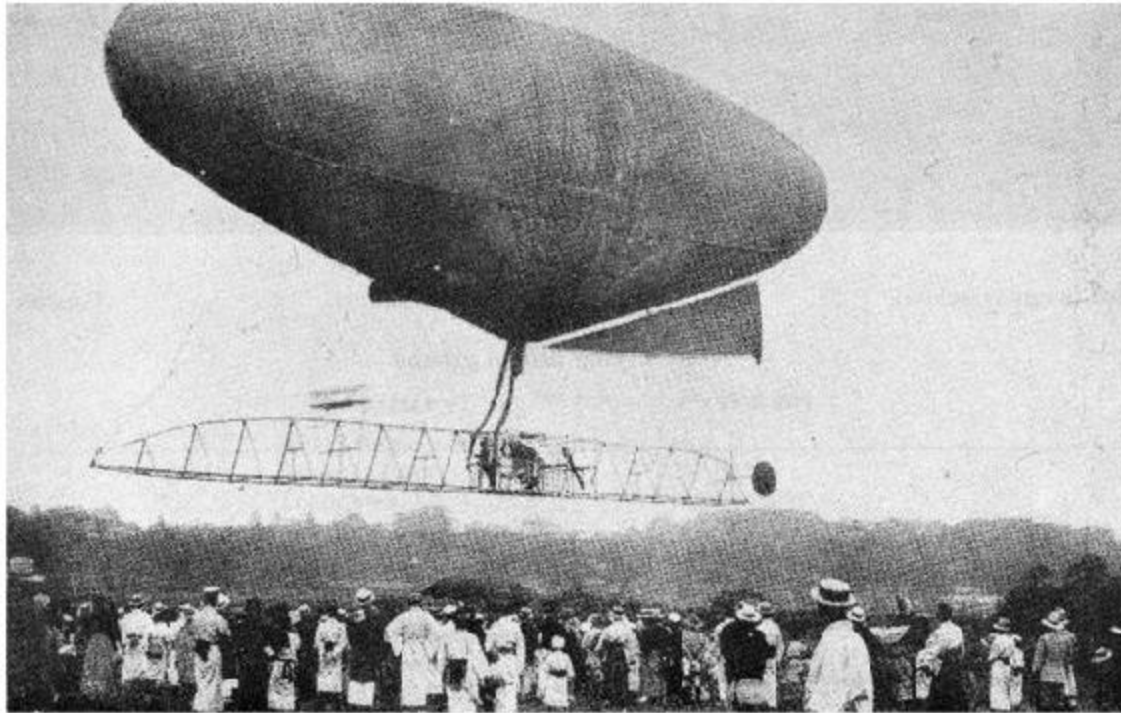

Photo by favour of M. Samuro Kuki.

**Maximum length**, feet (m.) **maximum diameter**, feet (m.) **volume**, 700 m<sup>3</sup>. (*about*)

**Gas bag**.—

**Motor**.—American make.

**Speed**.—

**Propeller**.—One.

**Steering**.—Biplane elevator forward. Triangular rudder in rear under gas bag.

**Remarks**.—Generally of American type.

## **MEXICAN.**

### **Army Aeroplanes.**

There are 2 old pattern *H. Farman*; also one or more *Curtiss* and *Wright* machines. Nothing seems doing with them.

### **AVIATORS.**

#### **Military.**

Martinez, N. (Ae. C. F. 462)

Mendia, (Ae. C. F. 680)

#### **Private.**

Duval, Raoul

Lebrija, Miguel

Morales

Noriega

Ramsey, E. L.

Saavedra, Alfonso

Probably 2 others

(The above are mostly amateur builders.)

## NORWEGIAN.

**Aerial Societies:—**



Aero Club, Norsk Flyveselskad (Christiana). Secretary, D. Barth.  
Norsk Luftseilads Forening (Christiana). President, H. Mohn.

**Aerial Journals:—**

None.

**Flying Grounds:—**

**Military Aviation.**

At the end of 1912 the Army possessed two 70 h.p. *M. Farmans* (Renault motors), and the Navy a 100 h.p. *N.A.G. Rumpler*.

For 1913 the purchase of further machines is contemplated for both arms.

**Private Aeroplanes.**

Total at end of 1911 1

At end of 1912 there were in existence 2—a *Grade* and a *Deperdussin*.

**AVIATORS.**

**Military.**

Dichi, Lieut.  
Jacobsen, Lieut.

**Private.**

Hansen.  
St. Dons.

**PERUVIAN.**

**Military Aeroplanes.**

The Peruvian Government has made a special grant for aviation students, and war machines are projected. Actual order to end of 1912 was one *Avro mono*.

**Private Aeroplanes.**

Total at end of 1910 3

1911 2

1912 *none* probably.

**AVIATORS.**

Bielovucic, J.  
Chavez, J.  
Monterc (766 A. C. F.)

**Peruvian aviators killed:**

1910.  
Chavez, G.

1911.  
Tenaud, C.

# PORTUGUESE.

(Revised by J. SCHIERE, Aeronautical Engineer.)

## Aerial Societies:—

Ae. C. de Portugal (R. Nova docklaemada d. ISL.)

## Aerial Journals:—

Rivista Aeronautica (Ae. C. Journal.)

## Flying Grounds:—

Campo do Seigcal.  
Mouchãvo da Povia.

## Private Aeroplanes.

Total at end of 1910	1
1911	2
1912	2

## Private Aviators.

De Castro, Sanchez  
De Silva, Gomez

## Military Aviation.

In 1912 a military corps was formed. At the end of 1912 it possessed *Avro* (1—50 h.p.), *Voisin* (1—80 h.p.), and *M. Farman* (1—80 h.p.) (since wrecked). 1 *Deperdussin*.

## Private Aviation.

In 1911 the *Gouveia* mono. was built, span 9 metres, but it failed to fly. Also the *Avante* biplane, which also failed. First flight in Portugal by a Portuguese was De Castro in September, 1912, with an old *Bleriot*.

## ROUMANIAN.

### Army Aeroplanes.

At end of March, 1913, there were several 80 h.p. *Bristol* monos., 2 *Bleriot*s, 1 *Nieuport*, 1 *Morane*, 2 *Vlaiclu*, and several *H. Farman* biplanes.

Government school is at Bucharest.

### AVIATORS.

#### Military.

Capsa, Lieut.  
Negrescu, Lieut.  
Protopescu, Lieut.  
Vacas, Lieut. Poly  
Zorileann, Lieut. (Ae. F. 587)

#### Private.

Bibesco, Prince (Ae. C. F. 20)  
Oznoth

### VLAICLU Monoplane.

Designed by Ouvret Vlaiclu. First shewn at the Vienna Exhibition, 1911. Modified; it flew very well indeed at Aspern, June, 1912. The 1912 model is of entirely novel type, a tail first monoplane with a propeller either end of the main planes, and a triangular tail aft. Principal details are:—**Length**, 34-2/3 feet (10.50 m.) **Span**, 30 feet (9.15 m.) **Height**, 12 feet (3.65 m.) Wing frame in three sections with gap between. **Motor**, 50 h.p., Gnome chain driven. **Fuselage**, old style; landing chassis on three wheels only, with a single ash skid in front. Covered in engine driving the 31 foot propeller shaft for the 2 propellers. Rear tail consists of 2 fixed planes, a triangular damping plane and a triangular keel plane. Forward, an elevator and two semi-circular rudders (double faced). From this combination remarkable results are achieved, and all gyrostatic effect from the propellers eliminated. *Control*, horizontal wheel on column. Elevator depressed or otherwise by action on column. *Note*.—At Vienna, 1912, this machine took first prize for the smallest circle and also for accurate bomb-dropping. The original machine was purchased by the Roumanian Army.

## RUSSIAN.

**General Note.**—In the number of military machines and general attention to aviation Russia is only second to France. There are no effective machines of Russian design, but the Aviatka, Dux & Lomatuk firms build at home under foreign license, and there is also the Kennedy school (Anglo-Russian).

### Aerial Societies:—

(Imperial) Aero Club.

1. Odessa branch.
2. Rostow and Don branch.
3. St. Petersburg "

Finland Ae. C., Helsingfors.

Kieff University Ae. C., Kieff.

Moscow Ae. C., Moscow.

Moscow Imp. Tech. College (Aviation Section).

Riga Ae. C., Riga.

Russian Aeronautical Society, St. Petersburg.

Sevastopol Ae. C.

Students' Aviation Club.

Tomsk Ae. C., Tomsk.

Volunteer Aerial Fleet.

### Aerial Journals:—

Aeronautical Journal of St. Petersburg.

*Aero* (6, Liteiny, St. Petersburg). Weekly.

*Dans l'Empire des Airs* (7, Rota 26, Petersburg). Fortnightly.

*Revue de Navigation Aérienne* (7 rue Stremmiannaya, Petersburg). Weekly.

*Sport* (25, Ekaterineska, Odessa).

*Wozdookhoplavatel* (St. Petersburg). Monthly.

*Wosduchoplavanie y Sport* (Moscow). Monthly.

### Flying Grounds:—

**Gatchina Park.**—Flying here under restrictions. V.F. school.

**Kieff.**—School for pilots.

**Kolomiaggi.**—Racecourse.

Novo Therkask.  
Odessa.

**St. Petersburg.**—Kennedy school.

**Sevastopol.**—Volunteer Fleet school.

Warsaw.

## RUSSIAN MILITARY AVIATION.

### Army Aviation.

Early in 1912, under the presidency of the Grand Duke Alexander, the special school of the Volunteer Aerial Association was finally formed at Sevastopol for the winter and Gatchina for the summer.

June 1912. Vote for 150 aeroplanes (140 to be built at home). Vote 1,050,000 roubles for new school at Tauride.

November, 1912. Military trials results. (1) Sikorsky in a *Sikorsky*. (2) Haber in a *M. Farman*. (3) Boutmy in a *Nieuport*.

December, 1912. Aeronautical school re-organised. Put under control of one commandant, one assistant, and four juniors. Course made seven months—15 pupils per school at a time. A one month course in aeroplanes, aerial motors, etc. Of the pupils, 10 will be selected for aeroplanes. New flying school established at Taskend in Turkestan.

March, 1913. New schools established at Moscow, Odessa and Omsk.

At the end of 1911 the total number of military aeroplanes was about 100. At the end of March, 1913, the total number was about 250, of which about 150 were modern. Principal types: *Albatross*, *Aviatik*, *Bristol*, *Deperdussin*, *Farman*, *Nieuport*, *Rumpler*, there being an average of 20 of each. The majority built under Russian license in Russia. The number of actual military pilots was 72. There is, however, a special volunteer corps of about 36 private aviators, bringing the available total to 108 or thereabouts.

### Navy Aviation.

July, 1912. Lieut. Andreadi, 50 h.p. *Nieuport*, did a flight with stops from Sevastopol to St. Petersburg.

September, 1912. Special naval aerodrome for hydro-avions ordered for Golodai Island, near Petersburg, bringing total of military and naval aerodromes to 6. *Sikorsky* hydro-avion acquired. Also an *M. Farman* ditto. New naval station projected at Libau.

October, 1912. Naval purchase of several *Curtiss* hydro-avions after trials at Sevastopol.

At the end of March, 1913, the approximate effective force was as follows (all hydros, or capable of being so fitted): 1 *Astra*, 1 *Breguet*, 2 *Donnet-Leveque*, 1 *Farman*, 4 *Paulhan Curtiss*, 2 *Nieuport* (50 h.p.), 1 *Sikorsky*. (A number of others on order.)

Early in 1913 experiments were carried out with a combination of floats and skids, invented by M. Lobanoff, of Moscow. This proved equally effective on land or water.

## AVIATORS.

The following are army, navy or volunteer aviators. The number is the Russian Ae. C., unless otherwise stated. F = French. Prefix + = killed. *n* = navy.

Abramowitch Wissewold (14)

Agababa, N. (668 F.)

Agofonoff (20)

Aleknovitch, G. (29)

Alexandroff, D. (472 F.)

*n* Andreadi, Lt.

Artsgouloff (44)

Avinass, J. (60)

Badowski, L.

Bakhmoutoff, N. (6)

Berdchenko, V. (7)

Bistritsky, V. (8)

Boukshevden, Bar. G. (10)

Boutmy (de), E.

Campo, Scipio (211 F.)

Childovski (67)

Chioni, B. (250)

Chimansky (27)

Choudinoff (46)

Dmitrieff, J. (9)

Dorogouski (125 F.)

Dougowezky, A. (1)

*n* Dybovski, V. (12)

Efimoff, M. (31 F.)

Efimoff, T.

Erdeli, G. (45)

Eristov, Prince (524 F.)

Evsukoff, P. (21)

Firstenberg

Flegfier, von.

Gelgar (33)  
Glouchenko, S. (48)  
Godoulsky, A. (59)  
Gorghkoff, G. (626 F.)  
Goumberto-Dros, B. (58)  
Grekoﬀ G. (5.)  
Grigoraschirilly (577 F.)  
Houeninsey, A. (227 F.)  
Husarenko (22)  
Illin, A. (16)  
Iougmeister (52)  
Jankovsky, G. (24)  
Joukoﬀ (37)  
Kaidenoﬀ (42)  
Kamensky, V. (66)  
Katzian, A.  
+ Kauzminski (228 F.)  
Kebouroﬀ, V. (210 F.)  
Kirchstern  
Kolchin, F. (28)  
Komaroff, M. (245 F.)  
Kostine, N. (223 F.)  
Kauznezoff, P.  
Kreiner, E.  
Kroumm, A.  
Lachtionoff, G. (57)  
Lambert (de) C. (8 F.)  
Lebedeff, V. (98 F.)  
Lerche, M. (25)  
Lewkowicz, H. (327 F.)  
Linno, G. (15)  
Lipowski, H. (330 F.)  
Kokteﬀ (61)  
Makaroff, D. (13)  
Makeef, P. (5)  
Matyevitch, Matzevitch (152 F.)  
n+Matyevitch, Capt. (178 F.)  
Meybaum, T.  
Miller (35)  
Monakoff, (565 F.)  
Naidenoﬀ, G.  
Naslennikoff, B.  
Nikiforoﬀ (18)  
Nikolaieﬀ (49)

Nikolsky, P. (17)  
Oulianine, S. (181 F.)  
Pehanovsky, B. (401 F.)  
+ Pietrowsky, G. (195 F.)  
Porcheron, J. (640 F.)  
Popoﬀ, N. (50 F.)  
Poliakoﬀ, A. (50)  
Poplavko (34)  
Pongolowski, W. (4)  
Pristchepoﬀ (38)  
Raevsky, A. (F.)  
Raygorodsky, A. (207 F.)  
Rossinsky (68)  
n Rouaroff, M. (245 F.)  
Rynin, N. (23)  
Sakoﬀ, N. de (627 F.)  
Salesky (41)  
Samoilo (11)  
Samouiloff, P. (51)  
Séméniovitch (226 F.)  
Semenko-Slavorossoﬀ, H. (40)  
Semitan (36)  
Seversky-Prokofieﬀ, N. (47)  
Sewkowicz, L.  
Shidloovsky, M.  
Shimansky, K.  
Shimkevitch, V.  
Sikorsky, I. (63)  
Skarginsky, A. (43)  
Slusarenko, W.  
+ Smith, V. (231 F.)  
Sobansky Graf. (3)  
Soechnikoff, A.  
Soupnevsky, C. (26)  
Springuefeld  
Sredinsky, A.  
Strelmkoff (71)  
Tchemiakoff (72)  
Tkatcheﬀ, V. (64)  
Tounochensky (32)  
Tselary, I. (54)  
Wassilieﬀ, A. (225 F.)  
Zaikine (191 F.)  
Zelinsky, Col. (273 F.)

## CIVILIAN AVIATORS.

There are very few purely civilian aviators in Russia. Russians who have obtained brevets include Mdles Anarta (52), Golantchikova (55), Zvereva (30), Count de Lambert, (8 F.) and Count Malynski (209 F.) and one or two others. Few or none do any flying now.

## RUSSIAN AEROPLANES.

### A-Z

#### AVIATIK.

St. Petersburger Aviatik Gesellschaft, Petersburg. Construct Aviatiks. (See Germany.)

#### BRONISLAWSKI.

Experimental biplane with special stabilising features.

#### DUX.

Fabrica Moscovita Tneerskaja "Dux," Lastawa, Moscow. Construct under license.

#### GELTOUCHOW.

W. G. Geltouchow and A. W. Preiss, 4 Piasnitzkajai, Moscow. Constructs.

#### GILBERT.

C. Gilbert, 195 Twerskaja, Moscow. Constructs.

#### KENNEDY.

Soc. d. Dirigibles and Aeroplanes Kennedy, St. Petersburg.

#### MOTOR.

Riga-Sassenhof.

**RODJESTVEISKY.**

Built a triplane in 1911.

**RUSSIAN MILITARY DIRIGIBLES (13).**

		(1)	(2)	(3 & 4)	(5, 6, 7)	(8)
	Name	LEBEDJ.	KOMMISSIONY.	<b>JASTREB and GOLOUBJ.</b>	<b>ZODIAC VII, VIII &amp; IX.</b>	PARSEVA
	Make	Lebaudy.	C. Bayard I.	Outchebny I & II.		Parseval
	Date	1910.	1910.	1910-11.	1910-11.	1911.
	System	Semi-rigid.	Non-rigid.	Semi-rigid.	Non-rigid.	Non-rigid.
Volume	c. feet (m <sup>3</sup> .)	3700	3000	1500	2140	7600
Length	feet (m.)	200 (61)	184 (56.25)	...	164 (50)	236 (72)
Diameter	feet (m.)	35-1/2 (10.80)	34-3/4 (10.58)	...	29-1/2 (9)	46 (14)
Gas Bags	fabric	Continental	Continental	...	Continental	Continental
	ballonets	1	1	...	1	2
	compartments	3	2	2	...	...
Lift	total tons	4	3-3/4	...	2	7
	useful tons	1-1/4	1	...	...	...
Motor	h.p.	1-70 Panhard (=70)	1-105 Clement B. (=105)	1-75 E.N.V. (=75)	1-60 Labor (=60)	2-110 N.A.G. (=220)
Propellers	number	2	1	1	1	two 4- bladed
Speed	m.p.h. (km.)	30 (49)	33-1/2 (54)	13 (21)	33-1/2 (54)	37 (59)

Notes

ex La  
Russie.

*Jastre*b reported  
wrecked, March,  
1913.

Carries 500  
litres of  
petrol. Has  
done 6-1/3  
hours at  
1500  
metres,  
with 9 on  
board.

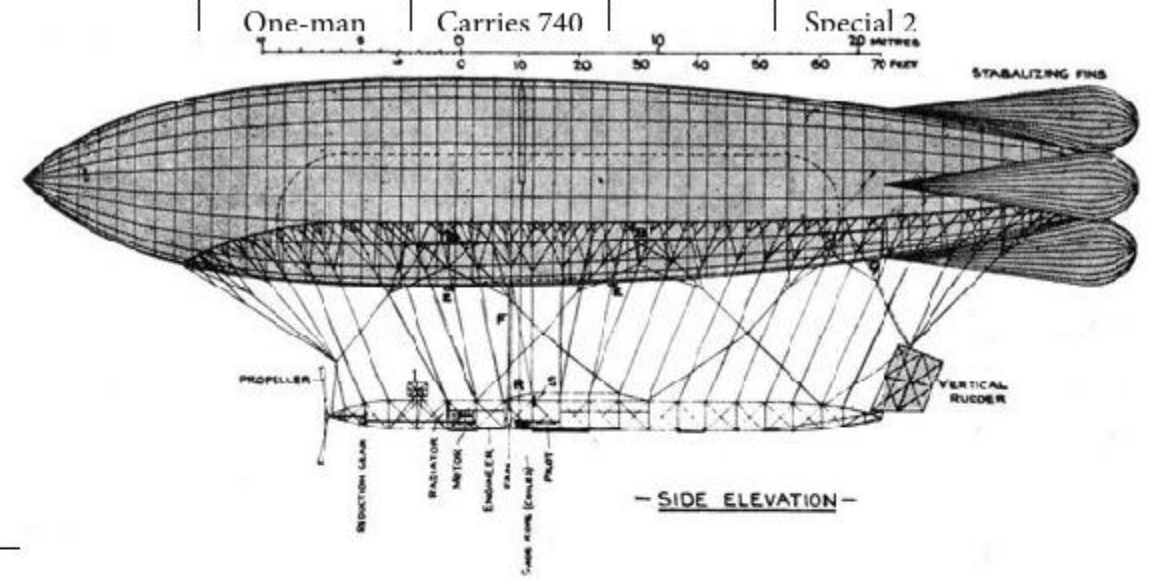

*Jastre*b (Outchebny).

Note.—Illustrations see next page.

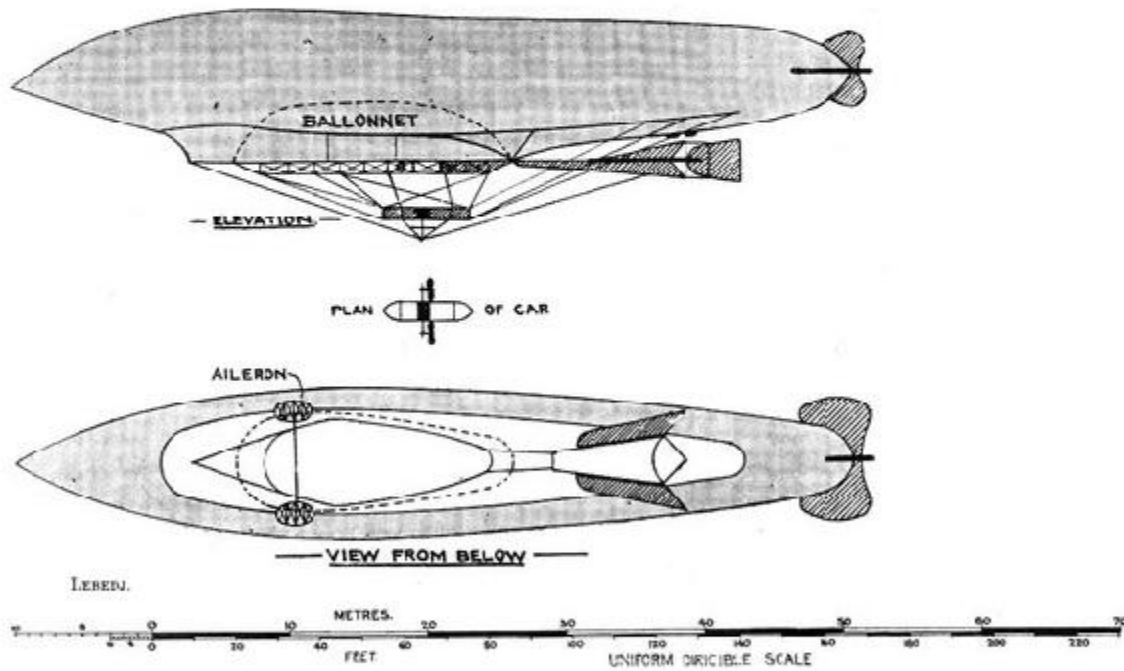

Lebedj. Uniform Dirigible Scale.

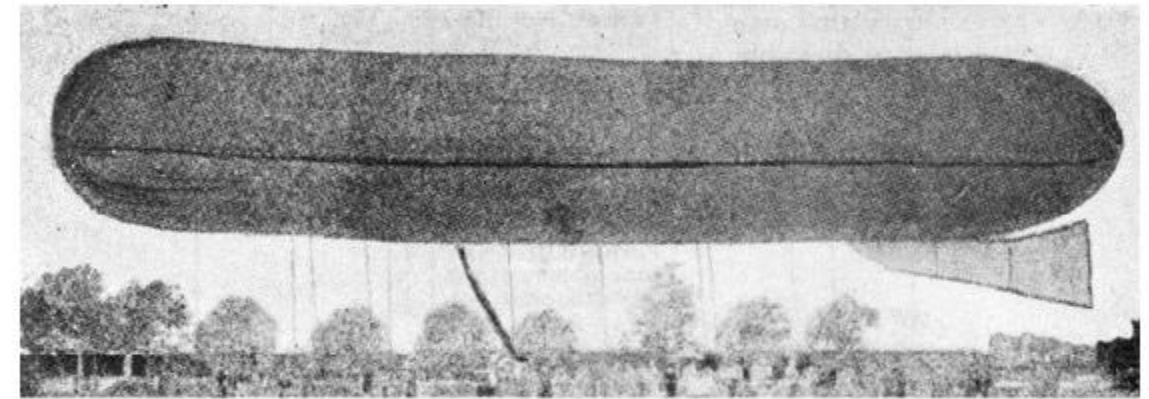

Kommissyony. Uniform Dirigible Scale.

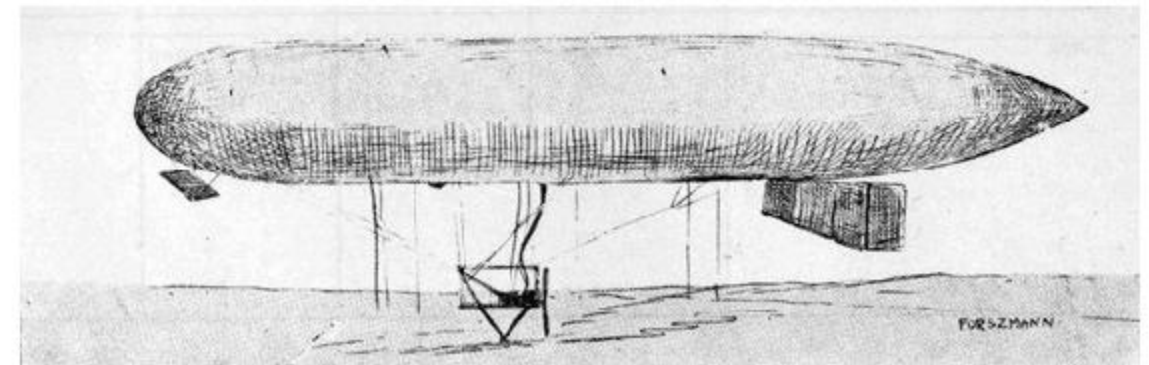

FURSZMANN.



*Note.*—The other dirigibles are of usual type. See France and Germany.

## **SERVIA.**

### **Military Aviation.**

At end of March, 1913, there were 7 aeroplanes, and 3 more (*Bleriot*s) on order.

## SPANISH.

### Aerial Societies:—

El Real Aëro Club de España (70 rue Alcala, Madrid).  
La Asociacion de Locomocion Aérea (20 Plaza de Cataluna, Barcelona).  
Real Aero Club d'España.  
Cataluna Ae. C.

### Aerial Journals:—

*Boletin Oficial de la Asociacion de Locomocion Aérea*, 20, Plaza de Cataluna, Barcelona (monthly).  
*España Automovil*, 5, plaza de Isabel II, Madrid. Official organ, Spanish R. Ae. C.  
*Revista de Locomotion Aerea*, 20, Plaza de Cataluna, Barcelona (monthly).

### Flying Grounds:—

**Carbouchelle** Military School.

### Army Aeroplanes.

There are 9 old *Farmans* (1910-11 model), and one or two more modern monoplanes: but little is doing.

Some hydro-aeroplanes are on order for the Navy.

## AVIATORS.

### Military.

Adaro, Lt. J.  
Alfaro, Lt. H.  
Arridaga, Capt.  
Berron, Lt. E.  
Echevarria, J.  
Gonzales, Capt. C. J.  
Granche  
Kindelan, Capt. A.

Menendez, M.  
Ortiz, So. Lt. J.  
Penas, M. de las  
Pujo, Capt. (467 F)

### Private.

Campano  
Dras, J. F.  
Jezzi, R. G. L. (British Ae. C. 44)<sup>[F]</sup>  
Lailhacar, de  
Pascal, Ferdinand  
Pimentel, B. L.  
Prince Alphonse d'Orleans (1)

The following Spanish aviators have been killed:—

1909.  
Fernandez, A.

1911.  
Pola, M.  
Mauvais

1912.  
Bayo, Capt.

[F] Jezzi lives in England where he is a well known amateur constructor.

### Military Dirigible Pilots.

Herrera, Lt. E.  
Kindelan y Duany, Capt. A.  
Vives y Vich, Col.

## SPANISH DIRIGIBLES (Non-rigid).

ESPANA. Military. (ASTRA class.)

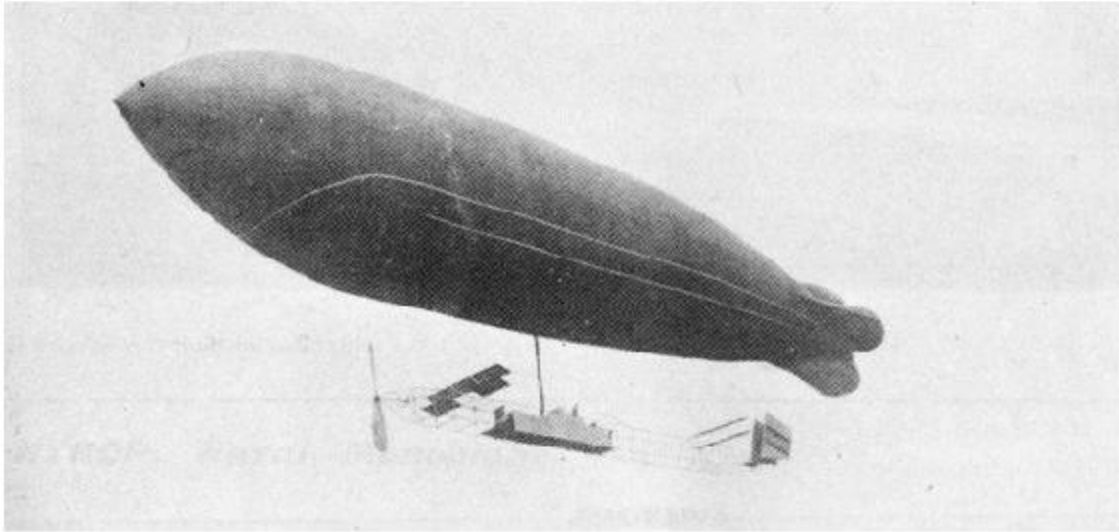

**Maximum length**, 197 feet (60 m.) **maximum diameter**, 35-1/3 feet (10.75 m.) **volume**, 43,057 c. feet (4,000 m<sup>3</sup>.)

**Total lift**.—9,700 lbs. (4,400 kgs.) **Useful lift**, lbs. ( kgs.)

**Gas bags**.—Yellow coloured rubber proofed Continental fabric.

**Motor**.—One 100 h.p. 4-cylinder Panhard.

**Speed**.—29 m.p.h.

**Propellers**.—1, at the front end of the car, of wood, "Integrale" type.

**Steering**.—As in *Clement Bayard I* and *Ville de Nancy*.

**Remarks**.—The two side stabilising shapes are duplicated, as they are in the *Ville de Paris*. A webbing stretched on steel tubes is introduced between the inner edges of the 4 main stabilising shapes to provide extra stabilising surface.

TORRES-QUEVEDO II. Military.

**Maximum length**, 147¾ feet (45 m.) **maximum diameter**, 32¾ feet (10 m.) **volume**, 56,700 c. feet (1,600 m<sup>3</sup>.)

**Total lift**.— lbs. ( kgs.) **Useful lift**, lbs. ( kgs.)

**Gas bags**.—

**Motor**.—60 h.p. Chenu.

**Speed**.—

**Propellers**.—

**Steering**.—

**Remarks**.—Designed by Captain Kindelan and Engineer Torres Quevedo.

## SWEDISH.

(Revised by Lieut. DAHLBECK, R. Swedish Navy.)

### **Aerial Societies:—**

Svenska Aëronautiska Sällskapet (Stockholm).  
Kungl. Automobil klubben: (Fenixpalatset, Stockholm).  
Svenska Motor-klubben: Aero sektion (Stockholm).

### **Aerial Journals:—**

*Svensk Motor-Tidning* (Fenixpalatset, Stockholm) Fortnightly.

### **Flying Grounds:—**

**Ljungbyhed** (Skåne), sheds.  
**Malmslätt**, sheds.

### **Military Aeroplanes.**

At the end of March, 1913, the Army possessed 1 monoplane, 1 biplane, and 2 biplanes building.

The Navy had 1 *Bleriot* type monoplane and 3 building.

At the end of 1912 there were 9 privately owned aeroplanes.

### **AVIATORS.**

(The number against any name is, unless otherwise stated, the Ae. C. Swedish pilot certificate.)

Military.

von Porat, Lieut. (6)  
Ljungner, Lieut. (7)  
Hamilton, Capt. (2)

Naval.

Dahlbeck, Lieut. (3) (British Ae. C. 120)  
Werner, Lieut. (9)

Private.

Cedarström, Baron C. (1)  
Fjällbäck (4)  
Ångström (5)  
Sundstedt (8)  
Thulin, M.A. (10)

## SWEDISH AEROPLANES.

**ASK. Monoplane.**

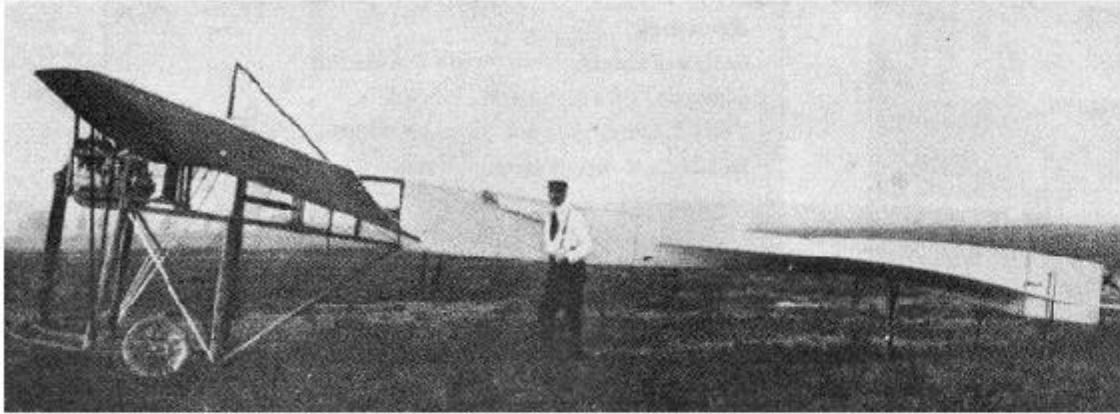

*Harlan* type. Built by Ask, 1911.

**NYROP. Naval Monoplane.**



*Bleriot* 2-seater. Built in Sweden by Nyrop, 1911. **Motor**, 50 h.p. Gnome.

## DAHLBECK.

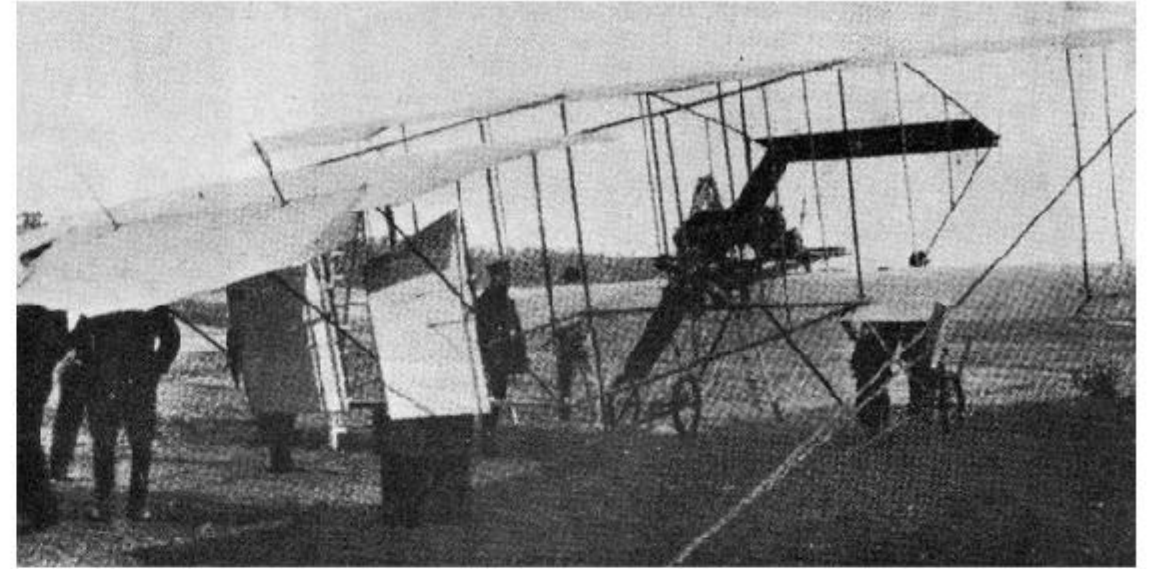

*Farman* type. Built by Lieut. Dahlbeck. 1913.

## SWISS.

(By our special Swiss editor.)

### Aerial Societies:—

Aero Club Suisse (3, Hirschengraben, Berne). Sec.: F. Filliot.  
*a* Ostschweizerischer V. für L. (Zürich).  
*b* Sektion Mittelschweiz (Bern).  
*c* Sektion Westschweiz (Romande) (Lausanne).  
*d* Club Suisse d'Aviation (Geneva).  
Club Genèveois d'Aviation (Geneva). Sec.: P. Brasier.  
Flügsport Klub (Rorschach). Sec.: A. Zürn.

### Aerial Journals:—

*Bulletin de l'Aero Club Suisse* (Berne). Monthly.  
*La Suisse Sportive* (16, Rue de Hesse, Geneva). Weekly.  
*Sport* (35, Boulevard Exterieur, Berne).  
*Automobil Revue* (Berne). Weekly.  
*Le Sport Suisse* (Geneva). Weekly.  
*L'Auto Sport* (Geneva). Weekly.  
A.C.S. (Swiss Aut. Clubs) (Geneva). Fortnightly.  
*Das Illustrierte Programm* (Zurich). Fortnightly.  
*Revue Weinfeldten*. Monthly.

### Flying Grounds:—

Avenches.  
**Collex-Versoix.** (Club Suisse d'Aviation).  
**Lucerne.**—60 acre park. Sheds.  
**Petit Lancy.** Geneva (Geneva Club).  
Dübendorf bei Zurich.

### Dirigible Station (with hangars):—

Lucerne.

## Army Aeroplanes.

At the end of March, 1913, there were no army aeroplanes, a *Farman* bought in 1911 having ceased to exist.

## Private Aeroplanes.

Total at end of 1910 about 10  
1911 " 15

At the end of March, 1913, there were about 15 privately owned aeroplanes.

## AVIATORS.

(The number against any name is, unless otherwise stated, the Ae. C. Suisse pilot certificate number.) + = killed.

### Military.

Real, Lieut. T. (4)  
+ Schmidt, Capt. J.

### Private.

Audemars, E. (7)  
Bianchi, P. (6)  
Bider, O. (32)  
+ Blane, M. (17)  
Bucher, M. (11)  
Burkard, H. (20)  
Burri, E. (24)  
Casser, E. (28)  
+ Cobioni, E. (15)  
Domenjoz, J. (10)  
Durafour, F. (3)  
Failloubaz, E. (1)  
Grandjean, R. (21)  
Gsell, R. (12)  
+ Hösli, G. (25)  
Hug, M. (18)  
Ingold, K. E. (35)

## SWISS AEROPLANES.

Jucker, A. (13)  
Kramer, H. (31)  
Mallei, A. (23)  
Parmelin, A. (22)  
+ Primavesi, E. (34)  
Rech, E. (29)  
Rettig, J. J. (27)  
Reynold, M. (19)  
Ruchonnet, E. (5)  
Rupp, A. (9)  
Salvioni, C. (16)  
+ Schmid, H. (14)  
Schumacher, J. (26)  
Taddoli, E. (2)  
Trepp, M. (30)  
Wyss P. A. (8)  
Züst, B. (33)

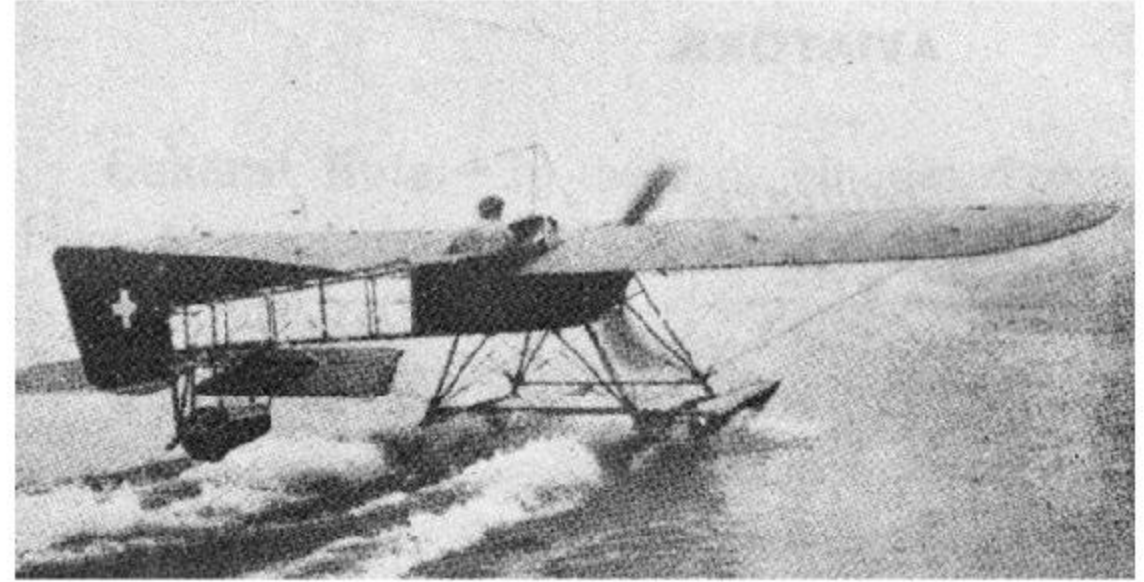

Grandjean.



Taddeoli.

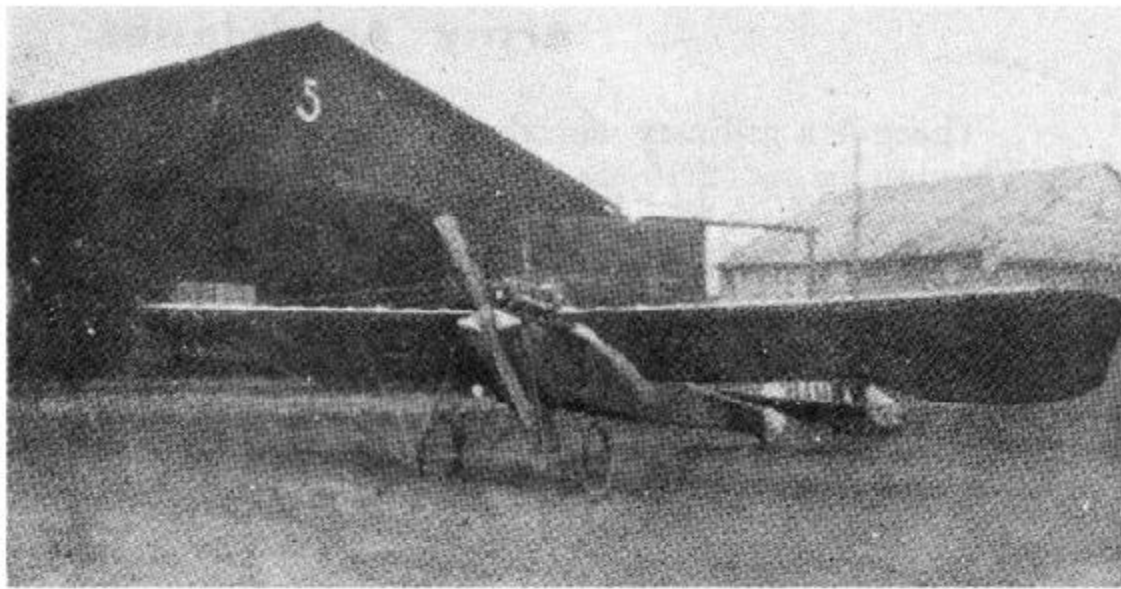

Wetterwald.

Model and date.		GRANDJEAN. Hydro-monoplane. 1911-12.	TADDEOLI. Monoplane. 1911-12.	WETTERWALD. Monoplane. 1912.
Length	feet (m.)	33 (10)	19-3/4 (6)	24-1/2 (7.50)
Span	feet (m.)	33 (10)	29-1/2 (9)	33 (10)
Area	sq. feet (m <sup>2</sup> .)	191 (18)	151 (14)	215 (20)
Weight	total lbs. (kgs.)	750 (340)	880 (400)	705 (320)
	useful, lbs. (kgs.)	310 (140)	330 (150)	...
Motor	h.p.	50 Oerlikon	50 Gnome	40 E.N.V.
Speed	max. m.p.h. (km.)	62 (100)	69 (110)	...
	min. m.p.h. (km.)	56 (90)	...	...
Number built during 1912		2	1	1

## TURKISH.

### Army Aeroplanes.

There is a military aerodrome at S. Stefano, with Amerigo, Renzel and Thanlau as instructors.

In March, 1913, there were about 12 monoplanes (*Harlans & Reys*), and one or two biplanes. Only one seems actually to have been used. Several other aeroplanes were captured during the war—generally in their packing cases unopened. In April, 50 machines were reported ordered in Germany.

### AVIATORS.

#### Military.

Fessa, Bey (780, F.)  
 Kienan, Lt. (797, F.)  
 Nouri, Lt.  
 Ratzian  
 Refik, Capt.  
 Sismanoglou, J.



## URUGUAY.

### Aeroplanes in the country.

None.

### AVIATOR:

Cameo, M. Garcia

## U.S.A.

(Edited by E. L. JONES, Editor of "Aeronautics," U.S.A.)

**General Note.**—In the early nineties, Professor Langley and the Bros. Wright were experimenting with heavier-than-air machines, but general interest in the subject is quite recent. Though some small dirigibles exist, American attention is mainly devoted to aeroplanes. Ballooning was quite the thing in 1907-11, but has languished.

It is stated that there are certainly no less than *two thousand* people in the U. S. A. who have built flying machines. The greater percentage of these have been home-made copies of standard machines. Individual builders of copies and freaks have diminished greatly in numbers, and there remains a few well-established manufacturers.

Although inventors are still prolific in the Patent Office and clubs numerous, the general public takes very slight intelligent interest in aviation. The majority of clubs are inactive.

In the year 1912 commercial development seemed to have great possibilities. The copyists were being weeded out and competent aeronautical constructors financed by adequate means began operations on systematic business lines. The latter half of the year saw a great slump. In the spring of 1913 prospects looked greatly improved, and there was generally increased activity.

### Aerial Journals:—

**Aeronautics.**—122, East 25th Street, New York. Monthly.

**Aircraft.**—37, East 28th Street, New York. Monthly.

**Fly.**—1701, Chestnut, Philadelphia, Pa. Monthly.

**Aero.**—Chicago, Ills. Weekly.

### Flying Grounds:—

**Belmont Park, N.Y.**—Old race track. Not very good. Scene of 1910 meet. 30 sheds occupied by few experimenters.

**Dayton.**—*Wright* school private field.

**Chicago, Ills.**—Two fine fields.

**Fort Myer, Va.**—Government and private sheds.

**Hammondspport, N.Y.**—*Curtiss* factory. Field (small) and lake for water planes.

**Los Angeles, Calif.**—Several fields in vicinity. Used for *Eaton* school and private flyers.

**Marblehead, Mass.**—Poor field. Home of Burgess C. Fine for hydro-aeroplanes.

**Mineola, N.Y.**—*Moisant*, *Sloane* and another school, and individuals. About 1 by 10 miles level field, without obstructions.

**Oakwood Heights, Staten I., N.Y.**—The Aeronautical Soc. grounds, on bay for use of hydro-aeroplanes.

**San Diego, Calif.**—Winter quarters *Curtiss* camp; also used by army flyers.

**San Francisco** (near).—Good.

**St. Louis, Mo.**—Kinloch Park. *Benoist* school and private owners.

## U. S. A. AERO CLUBS.

An attempt has been made here to give the name of every aero club that has been formed recently in the United States, or has been in existence for a long time. It is believed this list covers every club in the United States.

Many of these clubs are nothing but a name. They were formed to conduct meets or exhibitions, given by the various aeroplane concerns engaged in this business. Many clubs are not incorporated. Others have no organisation, being run by principals of boys' schools or classes.

Clubs even affiliated with the Aero Club of America have no members' meetings, nor have they in many cases even meeting rooms. There are but a half-dozen live aero clubs worthy the name in America. Three clubs own balloons, which are rented to members for ascensions. Little attempt is made by more than one or two associations to popularise aeronautics, to encourage experimenters, or to indulge in scientific work.

The Aero Club of America, the Aeronautical Society and Aero Club of Illinois, are the principal organisations. The Ae. C. represents the F.A.I., and has a beautiful club house. The Aeronautical Society has rooms in the United Engineering Building, conducts well-attended lectures twice a month, and has grounds on Straten Island (for hydro-aeroplanes and aeroplanes).

Clubs affiliated with the Ae. C. of America are marked \*

## CALIFORNIA.

New Orleans Aero Club, Wm. Allen, Sec., New Orleans

\*Aero Club of California, Prof. H. La V. Twining, Pres., 1308 Calumet St. Los Angeles.

\*Pacific Aero Club, Pacific Buildings, 331 Octavia Street, San Francisco

Postal Aero Club, 305 W. Santa Clara Street, San Jose

University of California Aero Club, T. W. Veitch, Sec., Berkeley

Oakland Aero Club, Oakland

\*Aero Club of Colorado, 36 West Colfax Avenue, Denver, Col.

Aero Club of Blackstonehill, Oakland, Calif, c/o W. R. Davis, Jr., 474 Prospect Street

Curtiss Amateur Aviation Club, Harold Scott, Secretary, Los Angeles

Santa Clara Valley Aero Club, Chamber of Commerce, San Jose

Aero Club of San Diego, San Diego, Colonel C. C. Collier, Pres.

Aero Club of Pasedena, W. J. Hogan, Pres., 635 Chamber of Commerce, Box 1054

## CONNECTICUT.

\*Aero Club of Connecticut, Pres., A. Holland Forbes, at Fairfield

Yale University Aero Club, New Haven

Aero Club of Hartford, Hiram Percy Maxim, Pres., Hartford

## CUBA.

\*Aero Club de Cuba, Ignario 5, Havana

## DELAWARE.

Aero Club of Delaware, Wilmington

## DISTRICT OF COLUMBIA.

Washington Aero Scientific Club, F. L. Rice, Sec., c/o Y.M.C.A., Washington

\*Aero Club of Washington, Dr. Albert F. Zahm, Sec., Cosmos Club, Washington

## FLORIDA.

Aeronautic Society of Florida, Davenport and Kerrison, Secs., 2014 Main Street, Jacksonville

## ILLINOIS.

\*Aero Club of Illinois, F. McCormick, Pres., 240 Michigan Avenue, Chicago

Aeroplane and Kite Club, E. E. Harbert, Pres., 2852 N. Clark Street, Chicago

University of Chicago Aero Club, Chicago

\*Aircraft Club of Peoria, c/o Leslie Lord, 505 E. Armstrong Street, Peoria  
Aeronautical Society of the University of Illinois, Urbana, R. Watts, Sec., 507 E. John Street,  
Champaigne

## **INDIANA.**

Purdue Aero Club, Purdue University, Lafayette  
South Bend Aero Club, South Bend.  
\*Aero Club of Indiana, Indianapolis

## **KANSAS.**

Aero Club of Topeka, Topeka  
\*Western Aero Association, E. S. Cole, Sec., Topeka  
Kansas State Aero Club, C. H. Lyons, Sec., Overland Park

## **KENTUCKY.**

Continental Aero Club, Richmond

## **LOUISIANA.**

Southern Aero Club, 809 Canal Street, New Orleans  
New Orleans Aero Club, Wm. Allen, Sec., New Orleans

## **MARYLAND.**

\*Aero Club of Baltimore, Col. Jerome H. Joyce, Pres., Baltimore

## **MASSACHUSETTS.**

Aero Club of North Adams, North Adams  
\*Aero Club of New England, A. R. Shrigley, Sec., 26 Tremont St., Boston  
Amherst Aero Club, Amherst  
\*Pittsfield Aero Club, L. J. Minahan, Pres., Pittsfield  
Springfield Aero Club, c/o Charles T. Shean, Pres., 3 John Street, Springfield  
Tufts College Aero Club, Tufts College  
\*Harvard Aeronautical Society, Prof. A. Lawrence Rotch, Pres., Blue Hill Observatory

Mass. Inst. of Technology Aero Club, John S. Selfridgem, Sec., Inst. of Technology, Boston  
Dartmouth Aero Club, Richard F. Paul, Sec., Dartmouth  
First Assn. of Licensed Pilots, Chas. J. Glidden, Pres., Hotel Somerset, Boston  
Williams Aeronautical Society, Williams College, Robert O. Starret, Sec., Williamstown

## **MICHIGAN.**

\*Aero Club of Michigan, C. B. du Charme, Sec., Detroit  
University of Michigan Aero Club, Ann Arbor

## **MINNESOTA.**

Minneapolis Junior Aero Club, Stillman Chase, Sec., 3047 5th Avenue, S., Minneapolis  
St. Louis Experimental Ass'n., 5346 Zealand Street, St. Louis  
\*Kansas City Aero Club, George M. Myers, Pres., Convention Hall, Kansas City

## **MISSOURI.**

\*Aero Club of St. Louis, 1429 Pine Street, St. Louis

## **MONTANA.**

Aero Club of St. Charles College, Helena

## **NEBRASKA.**

Aero Club of Nebraska, Col. Wm. H. Glassford, Pres., Fort Omaha  
Junior Aero Club or the Y.M.C.A., c/o Y.M.C.A., Omaha  
Lincoln Aero Club, Lincoln, c/o G. R. Brownfield, 1234 "O" Street  
Aviation Club of Nebraska, Arthur Frenzer, Sec., 2778 California Street, Omaha

## **NEW JERSEY.**

Princeton University Aero Club, Princeton  
Aeronautic Society of New Jersey, c/o N.J. Automobile & Motor Club, Broad Street, Newark  
Aero Club of New Jersey, c/o James K. Duffy, Sec., 315 Madison Avenue, New York  
New Jersey Aeronautical League, W. A. Kraus, Sec., Guttenberg  
Aero and Motor Club, Asbury Park

Atlantic City Aero Club, Col. Walter E. Edge, Sec., Atlantic City  
Model School Aero Club, Trenton, R. G. Teavitt, Sec.  
Trenton Aero Club, James Fenton, Sec., Trenton

## NEW YORK.

\*Aero Club of America, 297 Madison Avenue, Chas. Walsh, Sec.  
The Aeronautical Society, 250 W. 54th Street, Arnold Kruckman, Gen. Sec.  
Aeronautic Alumni Ass'n., c/o West Side Y.M.C.A., West 57th Street  
New York Model Aero Club, Adrien Lacroix, Sec., 141 Lexington Avenue  
National Model Aero Club, c/o A. Leo Stevens, 282 9th Avenue  
Stuyvesant Aeronautic Society, 345 East 15th Street, Percy W. Pierce, Sec.  
Columbia Aero Club, Columbia University, 116th Street  
Dewitt Clinton High School Aero Club, 58th Street and 10th Avenue  
\*Aero Club of Buffalo, Lafayette Hotel, Buffalo, N.Y.  
Thousand Islands Aero Club, c/o Dr. J. M. Gibbons, 168 Montague Street, Ithaca  
Aeronautic Section, Technology Club, Syracuse  
Boys' High School Aero Club, Henry St. Pieless, Sec., 815 Avenue, J., Brooklyn  
\*Rochester Aero Club, c/o L. J. Seely, 10 Culver Road, Rochester  
Aero Club of the Y.M.C.A., Harold C. Carpenter, Pres., White Plains  
Aero Club, Haliano, U.S.A., 135, West 12th Street, N.Y. Seventy-two members. C. Chiantelli,  
Sec.  
Junior Aero Club, c/o A. E. Horn, Public School, 77 Park Avenue and 84th Street  
Aero Club of Long Island, c/o Hohn H. Lisle, Alen Cove  
Commerce Aero Club, 65 West 117th Street  
\*Aero Club of New York, Garden City.  
Mechanics Aeronautical Ass'n., c/o H. H. Simms, 304 Cutler Building, Rochester  
Aeronautical Research Club of the Y.M.C.A., H. C. Myers, Sec., Buffalo  
Aero Club Italiano, Saverio A. Mascia, 403 Park Avenue  
Aeronautical Society of Women, Miss Dorothy E. Ball, Sec., 250 West 54th Street

## OHIO.

\*Aero Club of Ohio, Canton  
\*Aero Club of Dayton, Dayton  
International Aeroplane Club, Dayton  
Cleveland Aero Club, C. J. Forbes, Sec., Hollenden Hotel, Cleveland  
\*Aero Club of Cincinnati, c/o P. L. Mitchell, Traction Buildings, Cincinnati

## OREGON.

Portland Aero Club, E. Henry Wemme, Pres., Portland

## PENNSYLVANIA.

Aviation Section, Professional Chauffeurs Ass'n. of America, 1933 Spring Gardens, Phil.  
\*Aero Club of Pennsylvania, Rev. Geo. S. Gassner, Sec., Betz Buildings, Phil.  
Ben Franklin Aeronautical Ass'n., c/o Dr. T. Chalmers Fulton, 6th and Diamond Street, Phil.  
Philadelphia Aeronautical Recreation Society, Dr. Thos. E. Eldridge, Pres., 1639 N. Broad  
Street, Phil.  
Haverford College Aero Club, Haverford, Pa.  
Swartmore College Aero Club, Swartmore, Pa.  
Univ. of Penn. Aero Club, Univ. of Penn., Phil., Pa.  
Aero Club of Carnegie, Tech. Schools, Pittsburg, Pa.  
Intercollegiate Aeronautical Ass'n., Geo. A. Richardson, Pres., Univ. of Penn., Phil.  
Pittsburg Aero Club, H. P. Haas, Sec., Magel Buildings, Pittsburg, Pa.

## RHODE ISLAND.

Pawtucket Aero Club, Pawtucket  
Rhode Island Aeronautical Society, Providence, John J. Long, Sec., c/o Brown University

## TENNESSE.

Nashville Aero Club, Nashville, E. Fisher Coles, Sec.

## TEXAS.

Dallas Aero Club, c/o Chamber of Commerce  
San Antonio Aero Club, c/o Dr. Fred J. Fielding, 423 Hick's Buildings, San Antonio  
South Western Aero Club, P.O. Box 821, Fort Worth  
Texas Junior Aeronautical Ass'n., Hugh Dumas, Pres., Fort Worth

## UTAH.

Aero Club of Utah, c/o L. R. Culver, 11 Eagle Block, Salt Lake City  
Salt Lake City Aero Club, c/o Mr. Campbell, Walker Bank Buildings, Salt Lake City

## VERMONT.

Aero Club of Vermont, Chas. T. Fairfield, Pres., c/o Rutland News, Rutland

## VIRGINIA.

University of Virginia Aero Club, Stanford Swin, Sec., University of Virginia  
Virginia-Tennessee Aero Club, Bristol, Va-Tenn, C. W. Morey, Sec.

## WASHINGTON.

Aero Club of Washington, 415 Union Trust Buildings, Washington, D.C.  
Aero Club of Seattle, c/o M. Robert Guggenheim, 511 Lonan Buildings, Seattle  
Walla Walla Aero Club, Walla Walla

## WISCONSIN.

\*Milwaukee Aero Club, Milwaukee, c/o Major Henry B. Hersey, Chief of the Weather Bureau, Milwaukee  
Milwaukee Aeronautic Society, Pres., Sherman Brown, Manager of Davidson Theatre, Milwaukee

## U.S.A. MILITARY AVIATION.

### U. S. ARMY AEROPLANE SPECIFICATIONS. (1912).

#### SPEED SCOUT MILITARY AEROPLANE.

(1) Carry one person with the seat located to permit of the largest possible field of observation. (2) Ascend at the rate of 1500 feet in three minutes, while carrying fuel for one hour's flight. (3) Carry fuel for a three hours' flight. (4) Must be easily transportable by road, rail, etc., and easily and rapidly assembled and adjusted. (5) The starting and landing devices must be part of the machine itself, and it must be able to start without outside assistance. (6) The engine must be capable of throttling. (7) The engine will be subject to endurance test in the air of two hours' continuous flight. (8) Speed in the air of at least 65 miles an hour. (9) Capable of landing on and arising from ploughed fields. (10) The supporting surfaces must be of sufficient size to insure safe gliding in case the engine stops. (11) The efficiency and reliability of the system of control must have been demonstrated before the purchase order is placed. The aeroplane

must be capable of executing a figure eight within a rectangle 500 yards by 250 yards, and without decreasing its altitude more than 100 feet at the completion of the figure eight. This test to be made by aviator alone without carrying extra weight. (12) The extreme width of the aeroplane supporting surfaces must not exceed 40 feet.

#### SCOUT MILITARY AEROPLANE.

(1) The aeroplane must carry two persons with seats located to permit of the largest possible field of observation for both. (2) The control must be capable of use by either operator from either seat. (3) The machine must be able to ascend at least 2000 feet in ten minutes while carrying a weight of 600 lbs. including the aviator and passenger, 150 lbs. of gasoline, and extra weight to make 600 lbs. All of the extra weight must be carried on the engine section and not distributed over the wings. (4) The fuel and oil capacity must be sufficient for at least four hours continuous flight. This will be determined by a trial flight of at least one half-hour, measuring the consumption of gasoline while carrying the passenger and weight stated in paragraph 3. (5) Same as No. 4 above. (6) Same as No. 5 above. (7) The engine must be of American manufacture and capable of throttling to run at reduced speed. (8) Same as No. 7 above. This test will be made with aviator and passenger, extra weight and fuel enumerated in paragraphs 3 and 4. (9) The aeroplane must develop a speed in the air of at least forty miles an hour. This test will be made with aviator and passenger, extra weight and fuel enumerated in paragraphs 3 and 4. The maximum speed must not exceed sixty-five miles per hour. (10) Same as No. 9 above. This test will be made with aviator, passenger, extra weight and fuel enumerated in paragraphs 3 and 4. (11) Same as No. 10 above. (12) Same as No. 11 above. (13) Same as No. 12 above.

In 1913 additional requirements specified enclosed body, bullet-proof armour, .75 chrome steel, for engine and aviator, provision of necessary instruments and wireless, with, as desirable features, silencer and cut-out, self-starter and an efficient stabilising device.

At end of March, 1913, the effective Army aeroplanes consisted of three 50 h.p. *Wrights*, one *Wright-Burgess*, several old machines.

The Navy had two *Wright-Burgess* hydros and a few nondescripts. A *Burgess* flying boat since added.

The estimate for Army effectives at end of the present year (1913) is 21 (5 *Burgess*, 6 *Curtiss*, 10 *Wright*).

## AVIATORS.

(The numbers after any name is the number of the U. S. Aero Club certificate.)

## Army.

Arnold, Lieut. H. H. (29)  
Beck, P. Capt. (39)  
Brereton, Lt. L. H. (211)  
Burge, Corp. V. S. (154)  
Chandler, C. de F. Capt. (59)  
Foulois, Lieut. (140)  
Geiger, Lieut. H. (166)  
Goodier, Lt. L. E. (200)  
Graham, Lieut. H. (152)  
Hennessy, Capt. F. B. (153)  
Humphreys, Lieut.

Kirtland, Lieut. R.C. (45)  
Lahm, Lieut. F. P. (2)  
Love, Lieut. M. L. (155)  
McClaskey, Lieut. J. W. (90)  
McKay, Capt. G. W. (67)  
McLeary, Lieut. S. H. (210)  
McManus, Lieut.  
Milling, Lieut. (30)  
Rodgers, J. Lieut. (48)  
Sherman, Lieut. W. C. (151)  
Winder, Lieut.-Col. C.B. (130)

## Navy.

Herbster, Ens. (103)  
Ellyson, Lieut. T. G. (28)  
Rodgers, John, Lieut.  
Towers, Lieut. J. H. (62)

## U.S.A. PRIVATE AVIATORS (to end of 1911).

(The number against any name is, unless otherwise stated, the Ae. C. America pilot certificate number. Only a few American aviators have bothered to obtain the Ae. Certificate. America produces a large number of aviators who fly for pleasure or exhibitions only and have not gone into competitions under International Rules. These consequently do not bother about certificates; but most of those recorded could easily obtain them, if they cared to try.)

Adams, Clarence  
Adams, A. S. (215)  
Alvarez, F.  
Ambrose, Charles  
Andrews, Thornwell  
Apto, H. J.  
Arndt, Edw. F.  
Atwater, Mrs. L. J.  
Atwater, W. B. (98)  
Atwood, H. N. (33)  
Baker, G. H.  
Baldwin, Ivy  
Baldwin, Capt. T. S. (7)  
Barnett, A. E.  
Barton, Sam  
Bates, M. F. (66)  
Beachey, Hillery (89)  
Beachey, Lincoln (27)  
Beatty, G. W. (41)  
Beckly, Wm. A.  
Beers, W. C. (40)  
Benoist, T. W.  
Bergdoll, Louis, J.  
Betton, Kaid  
Bishop, Cortland  
Bleakley, W. H.  
Boandette, A. B.  
Bonner, G. T.  
Bonette, C. C.  
Bonney, L. W. (47)  
Brackett, A. J.  
Brewer, Roy  
Brindley, O. A. (46)  
Brinker, H. S.  
Brodie, O. W. (135)  
Brookins, W. R. (19)  
Brown, H. H. (58)  
Bumbaugh, Capt. G. L.  
Burgess, W. Starling (136)  
Burligh, Chas.  
Bush, J. F.  
Butler, P. J.  
Callon, J. L. (102)  
Champion, Frank (86)

Christmas, Wm.  
Cannon, Jack  
Cline, W. F.  
Coffyn, F. C. (26)  
Cole, R.  
Coleman, R. F.  
Cook, W. B. (95)  
Cooke, Henry C.  
Cooke, F. G. (26)  
Cooper, John D. (60)  
Costello, A. B.  
Coutourier, C. (79)  
Crewelson, W. H.  
Cross, Redmond W. (35)  
Crosby, R. W.  
Cummings, J. A.  
Curtiss, Glenn H. (1) & (Ae. C. F. 1)  
Curzon, J. W.  
DeGiers, C.  
De Hart, D. C.  
De Kor, F. (72)  
Dennis, D. L.  
Dixon, S. D.  
Dougherty, E. S. (87)  
Doyle, H.  
Drew, A. (50)  
Drexel, J. A. (8)  
Durgan, W. E.  
Dyott, G. M.  
Eaton, Warren  
Ecot, Robert G.  
Eells, Fred.  
Elton, Albert (75)  
Engel, A. J.  
Erickson, Louis, G.  
Eshoo, D.  
Evans, W.  
Ey, G.  
Fish, Farnam (85)  
Fortney, Lewis  
Fowler, R. G.  
Freeman, A. (84)  
Fuchs, Joseph  
Funk, T. B.

Gallaudet, E. F. (32)  
Games, A. B.  
Gantz, Saxe P.  
Gardener, Hubbard G.  
Garner, R. W.  
Gaskell, Bud  
Gratz, H. F.  
Gray, George  
Green, William, Dr.  
Gregory, Donald  
Greider, C.  
Greider, J.  
Gressier, Romaine  
Guey, Fung Joe  
Hadley, C. O.  
Hall,  
Hamilton, C. K. (12)  
Hamilton, J. W.  
Hamilton, Thos. W.  
Hammond, Lee (34)  
Harper  
Harkness, H. S. (16)  
Harmon, C. B. (6)  
Hartman, A.  
Haupt, Willie  
Havens, Beckwith (127)  
Hendrian, A.  
Henning, J. C.  
Henningsen, Fred  
Heth, Eugene  
Henry, R. St.  
Hilliard, W. M. (Brit. Ae. C. 102)  
Hills, H. V.  
Hofer, W.  
Hoff, Wm. H. (91)  
Hoflake, Charles  
Holden, J. J.  
Holt, L. E. (63)  
Hoover, Fred. (100)  
Hoover, H. H.  
Huddleston, E. D.  
James, Stanley  
Janicke, W.  
Jannus, Anthony (80)

Jennings, J. C.  
Jerwan, S. S. (54)  
Johnson, Frank H.  
Johnson, Walter E. (164)  
Jumel, August  
Kantner, H. (65)  
Kellrey, H.  
Kemmerle, Horace  
Kennedy, F. M. (97)  
Kiley, J. E.  
Kimball, Wilbur R.  
Klein, H. H.  
Klockles, J. G.  
Korn, Edward  
Krasting, Theodore  
La Chapelle, Duval  
Lambert, A. B. (61)  
Lambreath, C. E.  
Lapadat, N.  
Laser, G. F.  
Le Van, Howard  
Lewis, S. C. (92)  
Lewkowicz, Ladis  
Lidstone, Ed. S.  
Lillie, M. T. (73)  
Lockwood, Chas.  
Longfellow, H. W.  
Loose, Geo. H.  
Lougheed, A.  
Longo, T.  
Ludwig, Vandy  
Maier  
Manners, George  
Mars, J. C. (11)  
Martin, J. B.  
Martin, G. L. (56)  
Martin, J. V.  
Massar, A. M.  
Masson  
Matalach, S. H.  
Mattingley, O. A.  
Maynard, Arthur  
Mayo, Albert (99)  
McCally, J. B. (94)

McCarty, James  
McClellam  
McCollum, W. C.  
McCurdy, J. A. D. (18)  
McGoey, Thomas  
McNamara, Geo. E.  
McManus, L.  
McMahon, A. J.  
Medrick, F. H.  
Meyerhoffer, Orvar  
Miller, Clinton R.  
Moisant, Miss M. E. (44)  
Morok, Chas. B.  
Mourfield, Carl  
Murias, De E. F. (38)  
Murphy, T.  
Murphy, Wm.  
Neidmiller, Ed.  
Nelson, N. B.  
Nelson, Nels. T.  
Ovington, E. L.  
Page, P. W. (68)  
Paine, N. B.  
Paridon, Michael  
Park, Henry  
Paulding, Dwight  
Paulhan, L. (3)  
Pfiel, P.  
Post, Augustus  
Powers, H. W.  
Prince, Norman (55)  
Prentice,  
Prospect, Louis  
Prowse, C. O.  
Raiche, Mrs. F.  
Ragot, Louis  
Reichert, H. D. W. (82)  
Remington, Earle  
Reynolds, Dr. Percy, L.  
Richter, J. (81)  
Riggs, E.  
Roat, Arthur R.  
Robinson, H. (42)  
Roehrig, B. F.



Rowe, F. E.  
Russell, Geo.  
Sackett, Harry  
Sands, H. Hayden (Ae. C. F. 70)  
Schafer, G. E.  
Schmidt, G. S.  
Schneider, Fred, P.  
Schulz, G. C.  
Schwartz, A.  
Schwister, John  
Scott, Miss B.  
Seeman, J. R.  
Seignor, H. A.  
Seligman, J. (64)  
Seymour, Joseph  
Sellers, M. B.  
Shelton, T.  
Sherwood, Oliver, B.  
Shneider, Fred.  
Shoemaker, Chas. W. (93)  
Sill, F.  
Simmonds, O. G. (145)  
Skinner, S. R.  
Slaik, E.  
Slavin, J. J.  
Smith, A.  
Smith, Kyle  
Smith, R. M.  
Sommerville, W. E.  
Soreusen, Prof.  
Sparling, J. N.  
Steitz, F. M. (88)  
Stewart, J. G.  
Stone, A. (Ae. C. F. 15)  
Summer, Gill.  
Suppe,  
Talmage, M. P.  
Takisow,  
Tarbox, J.  
Thomas, W. T.  
Thomas, O. W.  
Thompson, George  
Tickell, Sam  
Timothy, S. R.

Troxey  
Turpin, J. C. (22)  
Tuttle, T. T.  
Vanderbilt, W. K.  
Vaughan, Stanley  
Vogt, Jesse S.  
Walden, Dr. H. W. (74)  
Walker, Clarence  
Ward, J. J. (52)  
Warner, A. P.  
Webster, C. L. (69)  
Weeks, F. W.  
Wells, G.  
Wetzig, H. H.  
Weymann, Charles (14)  
Wilcox  
Wildman, Dock  
Willard, C. F. (10)  
Williams, Beryl (71)  
Williams, B. J.  
Willoughby, Capt. Hugh L.  
Wilson, Edward  
Wiseman, Fred. E.  
Witmer, C. C. (53)  
Worden, John H. (76)  
Wright, Orville (4) (Ae. C. F. 14)  
Wright, Wilbur (5) (Ae. C. F. 15)  
Young, C. M.  
Yan, J.

The following American aviators have been killed:—

1908.

Selfridge, Lt. (Army)

1910.

Johnstone, R. (20)

Moisant, J. B. (13)

1911.

Badger, Wm. R. (36)

Castellane, Tony

Clark, C. B., Dr.

Dixon, Cromwell (43)

Ely, Eugene

Frisbie, J. J. (24)  
Hoxsey, Arch. (21)  
Johnston, St. Croix  
Kelly, Lieut. (Army)  
Kreamer, Dan. A.  
Miller, F. H.  
Oxley  
Penot, Marcel  
Purvis, Wm. G.  
Rosenbaum, Louis  
Schriver, Tod (9)

#### U.S.A. PRIVATE AVIATORS. (Brevets, 1912.)

Aldasoro, J. P. (217)  
Aldasoro, E. A. (218)  
Andrews, W. D. (124)  
Arnold, G. (198)  
Barlow, F. E. (139)  
Beckwith, S. F. (137)  
Beech, A. C. (168)  
Belcher, O. T. (158)  
Bell, Dr. F. J. (196)  
Bell, G. E. (201)  
Bergdoll, G. C. (169)  
Berlin, C. A. (109)  
Bleakley, W. H. (206)  
Bouldin, W. (157)  
Boysdorfer, C. (193)  
Brown, R. M. (185)  
Bryant, G. M. (208)  
Burnside, F. H. (212)  
Carlstrom, O. G. (145)  
Colovon, P. (160)  
Crossley, S. J. (187)  
Dalwigk, G. B. (190)  
De Hart, D. C. (129)  
Eaton, W. S. (128)  
Edelman, D. (191)  
Elliott, R. (178)  
Figyelmessy, H. (203)  
Fritts, E. V. (213)  
Gilpatric, J. G. (171)  
Gray, G. A. (142)

Gray, J. F. (150)  
Gunn, T. (131)  
Hattemer, H. L. (147)  
Hemstraught, W. H. (146)  
Hetlick, W. A., jr. (197)  
Hild, F. C. (216)  
Hunt, E. N. (163)  
Holmes, H. (204)  
Johnson, R. R. (205)  
Kabitzke, W. (126)  
Kammski, J. G. (121)  
Kemper, F. W. (119)  
Klockler, J. G. (125)  
Korn, E. (171)  
Lamkey, W. A. (183)  
Law, R. B. (188)  
Maroney, T. T. (106)  
Masson, D. (202)  
McMillen, R. E. (111)  
Meyer, C. (176)  
Miller, B. A. (173)  
Niles, C. F. (181)  
Park, H. (113)  
Peoli, C. (141)  
Piceller, W. (116)  
Prodgers, C. B. (159)  
Reid, M. E. (114)  
Reid, P. H. (179)  
Remer, L. H., de (115)  
Richardson, R. H. C. (174)  
Robinson, R. W. C. (162)  
Ruiz, H. (182)  
Russell, R. B. (132)  
Salinas, A. (170)  
Salinas, G. (172)  
Schaeffer, J. S. (177)  
Scholovinck, E. (195)  
Schuman, F. J. (143)  
Singh, M. M. (123)  
Sjolander, C. T. (138)  
Smith, J. F. (207)  
Spaulding, J. D. (107)  
Stark, W. M. (110)  
Stinson, K. (148)

Sverkerson, J. S. (180)  
Tait, G. M. (184)  
Takeiski, K. (122)  
Terrill, F. J. (108)  
Thomson, C. (112)  
Thompson, De L. (134)  
Twombly, W. I. (149)  
Vought, C. M. (156)  
Waite, H. R. (186)  
Weeks, E. O. (214)  
Weiner, T. (167)  
Wiggins, C. L. (175)  
Wood, C. M. (209)

**U.S. Aviators killed:**  
*Continued.*

**In 1912.**

Blair, R.  
Chambers, W. B.  
Clarke, J. (133)  
Gill, H. W. (31)  
Hazelhurst, Lieut.  
Kearney, H. F. (83)  
Kondo, M. (120)  
Lawrence, C.  
Longstaffe, J. L.  
Mitchell, L. (51)  
Page, R. (96)  
Parmelee (25)  
Peck, P. (57)  
Quimby, Miss H. (37)  
Rodgers, C. P. (49)  
Rockwell, Lt. L. C. (165)  
Scott, Corp. F.  
Southard, F. J.  
Stevenson, J.  
Turner, H.  
Underwood, G.  
Walsh, C. F.  
Welsh, A. L. (23)

**In 1913.**

Boland, F. E.  
Chandler, Lieut. R.  
Park, Lieut. T. D. (223)

## U.S.A. AEROPLANES.

### A

#### **AERIAL EXHIBITION Co. (Biplane),**

1777, Broadway, New York. Built a *Curtiss* type with Kirkham motor, 1911. 2 skids, with wheel between, and usual *Farman* rubber shock absorbers.

#### **AERIAL YACHT CO.,**

San Francisco. Inc. 1913. Capital, \$25,000.

#### **AERONAUTICAL SUPPLY CO.**

See *Cordeaux-Etter*.

#### **AMERICAN AEROPLANE SUPPLY HOUSE (Monoplane),**

266, Main Street, Hempstead, N.Y. Builders of monoplanes after the *Bleriot* type. Half-a-dozen machines were built and sold during 1911. Fitted with Gnomes or American engines.

### B

#### **BALDWIN Biplanes.**

Captain Thos. S. Baldwin, PO Box, 78, Madison Square, N.Y. About half-a-dozen steel biplanes have been produced in 1911 by Captain Baldwin, and he and other aviators, Badger, Hammond, Miss Scott Mass, etc., have flown these at various exhibitions and meets, and are classed with well-known successful American biplanes.



Photo, Edwin Levick, N.Y.

Details of *Baldwin* ("Red Devil").

**Length.**—28¼ feet (8.60 m.) **Span.**—28¾ feet (8.75 m.) **Motor.**—50-60 h.p. Hall-Scott **Propeller.**—One Requa-Gibson in rear of main planes. Diameter, 7 feet (2.13 m.) Pitch, 6 feet (1.82 m.) **Speed.**—60 m.p.h. (97 k.p.h.)

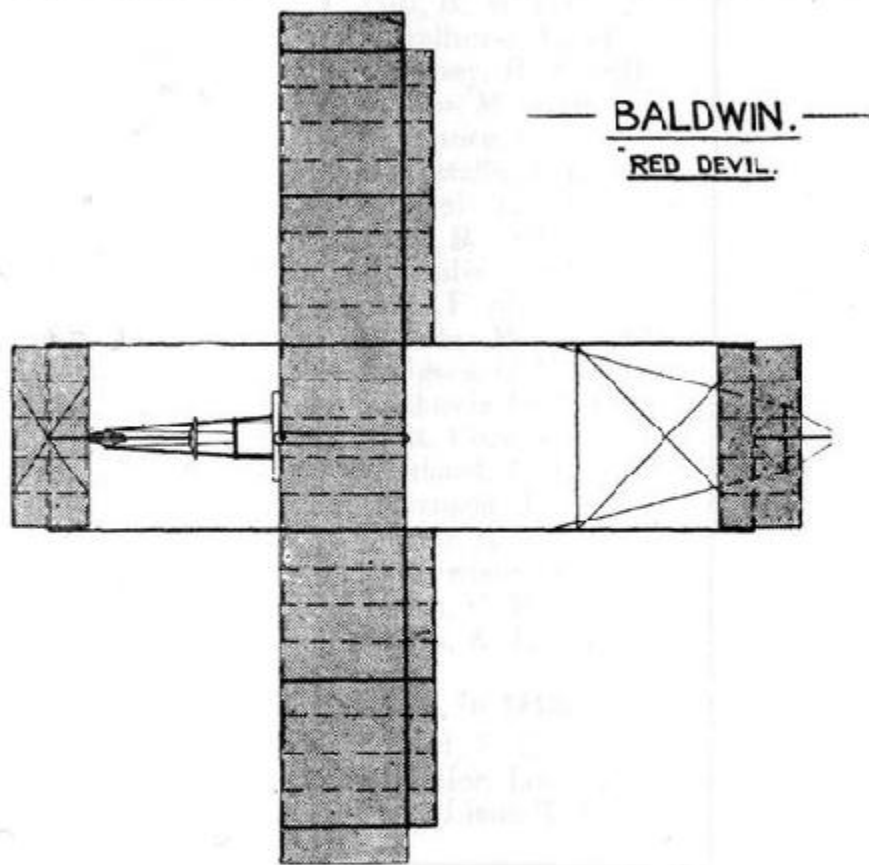
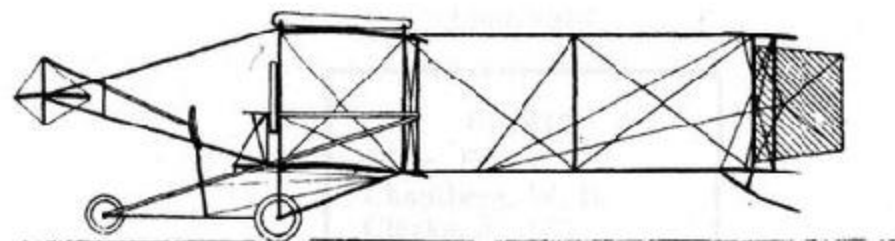

**BALDWIN.**

**RED DEVIL.**

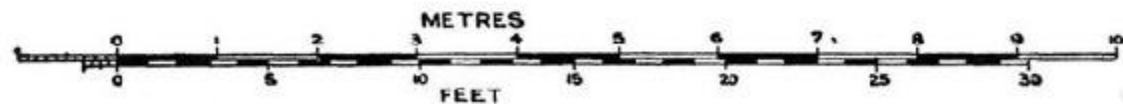

BALDWIN. RED DEVIL. Uniform Aeroplane Scale

**BENOIST.**

Benoist Aircraft Co., 6628, Delmar Boulevard, St. Louis, Mo. (formerly Aeronautic Supply Co.)

Model and date.		1912-13. "Headless."	1913. Flying boat. Tandem biplane.
Length	feet (m.)	22-1/2 (6.85)	27
Span	feet (m.)	30 (9.15)	42-1/6 (12.80)
Area	sq. feet (m <sup>2</sup> .)	...	...
Weight	total lbs. (kgs.)	...	1004 (455)
	useful lbs. (kgs.)	...	...
Motor	h.p.	...	75 Roberts
Speed	max. m.p.h. (km.)	68 (110)	...
	min. m.p.h. (km.)	31 (50)	...
Endurance	hrs.	3	...

Notes.—The boat of the flying boat is 23-5/6 feet long, by 2 feet 2½ inches wide. Shipable wheels. See *Aeronautics*, January, 1913.

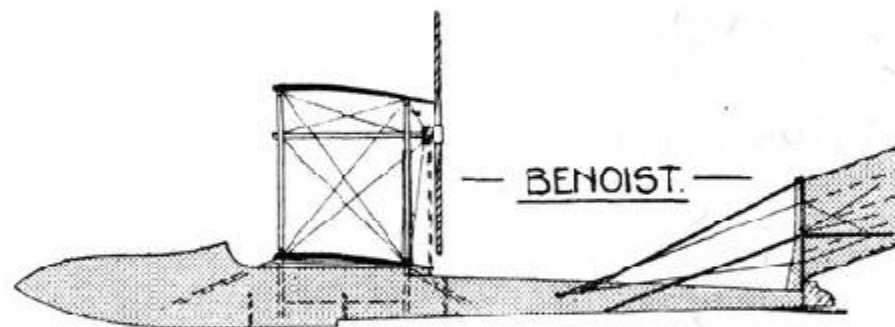

**BENOIST.**

Flying boat.

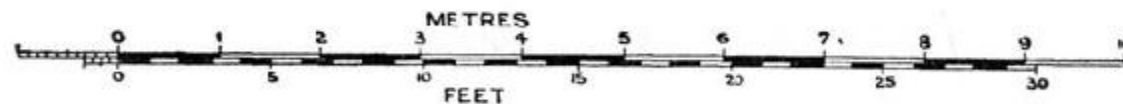

BENOIST. Flying boat. Uniform Aeroplane Scale

**BOLAND.**

Boland Aeroplane & Motor Co., 1821, Broadway, New York. Works: Ft. Center St. Newark, N.J.

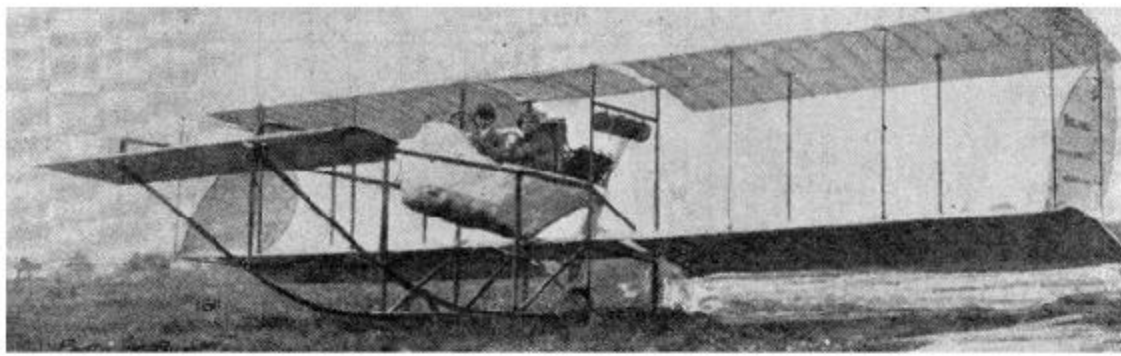

Model and date.		1913. "Tailless."
Length	feet (m.)	21-1/6 (6.45)
Span	feet (m.)	35-1/2 (10.80)
Area	sq. feet (m <sup>2</sup> .)	...
Weight	total lbs. (kgs.)	900 (408)
	useful lbs. (kgs.)	...
Motor	h.p.	60 Boland
Speed	m.p.h. (km.)	60 (95)
Number built during 1912		1

A refinement of the original machine of the late F. E. Boland, which first flew in 1911. Control by two special jibs which work inward. Designed to be used also as a hydro, with three step floats. No rudder or ailerons. Full details, etc., see *Aeronautics*, U.S.A., May, 1913, and *Aircraft*, U.S.A., May, 1913.

**BURGESS.** Burgess Co. & Curtis, Marblehead, Mass. Built *Wright* types under license, also machines of their own.

Model and date.		Military tractor. 1912-13.	Coast defence hydro. 1913.	Naval flying boat. 1913.
Length	feet (m.)	37-3/4 (8.50)	33-1/3 (9.55)	31 (9.45)
Span	feet (m.)	34-1/2 (10.50)	37-3/4 (12)	43 (13.10)
				36 (10.97)
Area	sq. feet (m <sup>2</sup> .)	...	...	397 (37)
Weight	total lbs. (kgs.)	...	...	...
	useful lbs. (kgs.)	...	775 (352)	...
Motor	h.p.	70 Renault	60 Sturtevant <i>muffled</i>	70 Renault
Speed	m.p.h. (km.)	45 (70)	59 (95)	...
Endurance	hrs.	4-1/2	4-1/2	...
Number built during 1912		...	...	...
<i>Remarks.--</i>		Lumina fabric. Single screw. Details, <i>Aeronautics</i> , (U.S.A.), May-June, 1912.	Special clear view for observation. 2--1 step mahogany and copper floats. Useful weight includes floats. Details, <i>Aeronautics</i> , (U.S.A.), Feb., 1913.	Boat 29-1/2 feet long. 2--2 step floats. Petrol, 48 gallons. Details, <i>Aeronautics</i> , (U.S.A.), May, 1913.

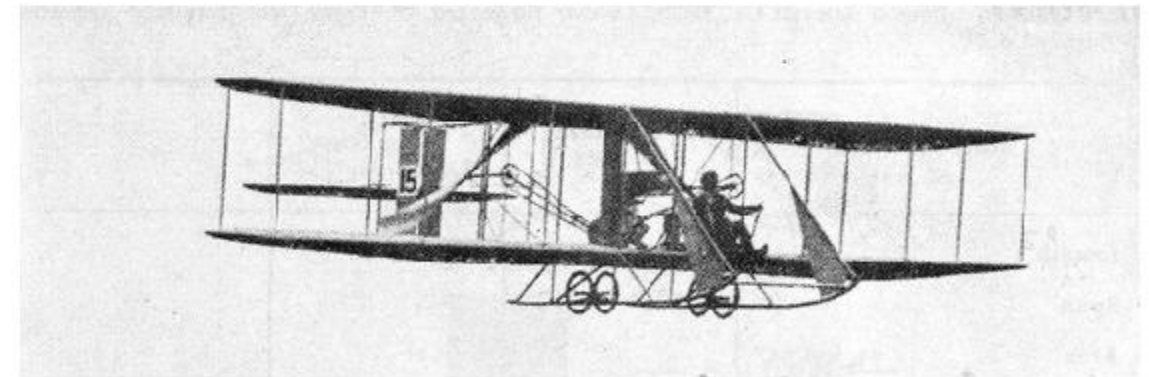

Burgess-Wright.

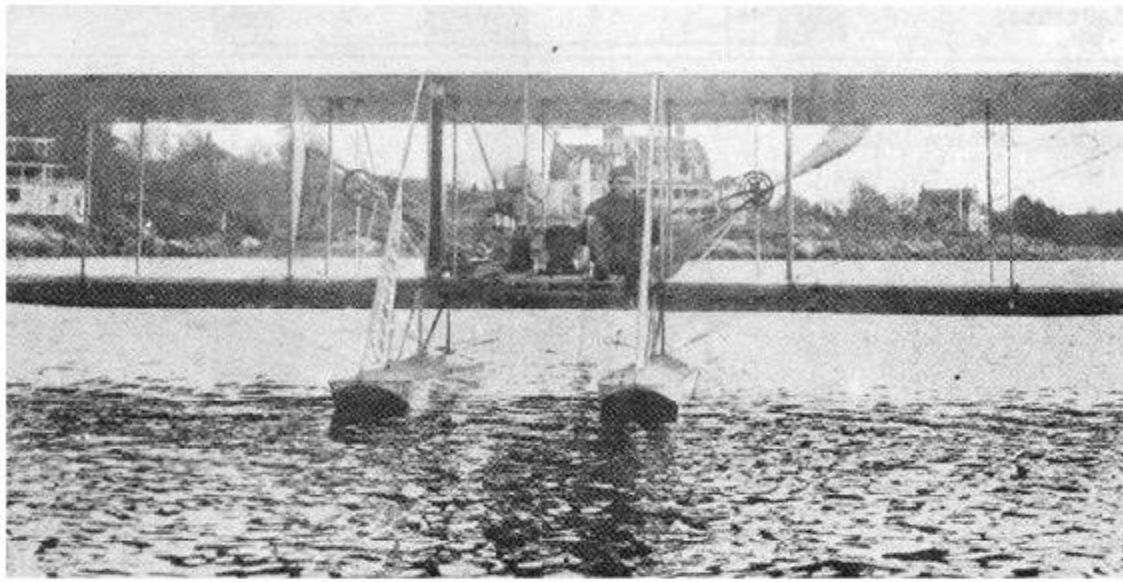

Burgess-Wright as a hydro (the U.S. Navy has two of these).

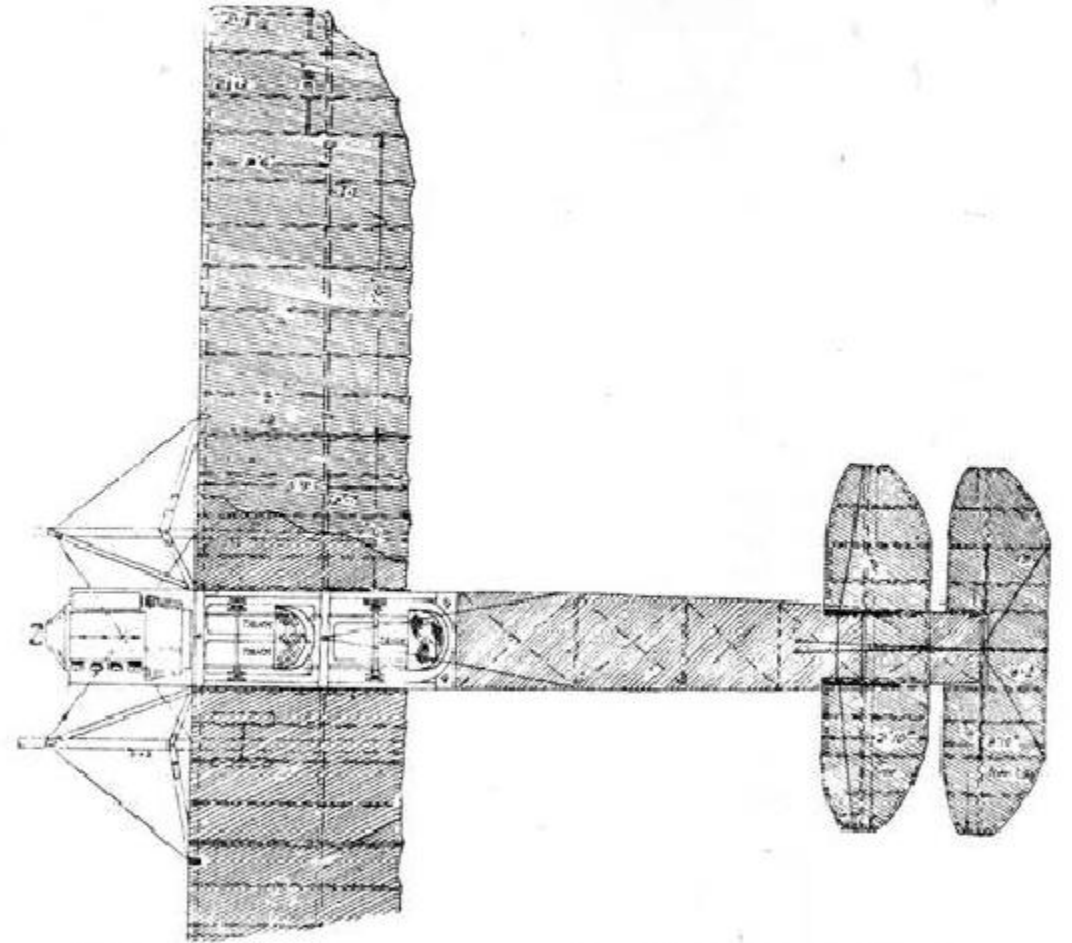
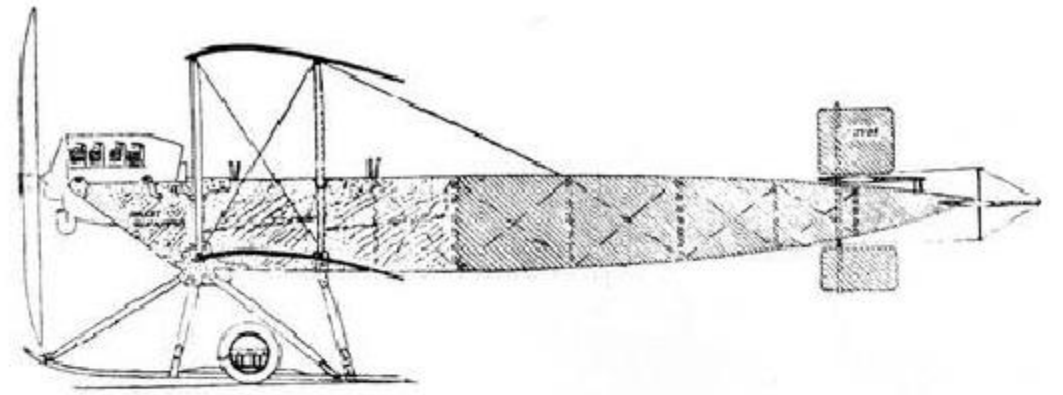

Military tractor.

*By favour of "Aeronautics," U.S.A.*



Military tractor. By favour of "Aeronautics," U.S.A. Uniform Aeroplane Scale

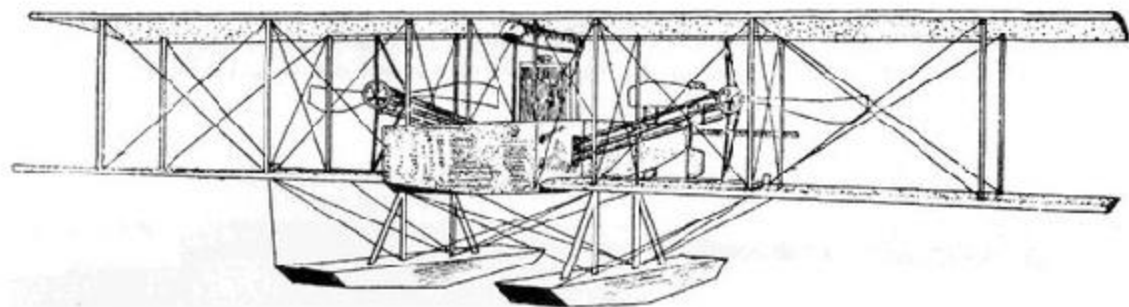

"Coast defense" hydro. From "Aeronautics."

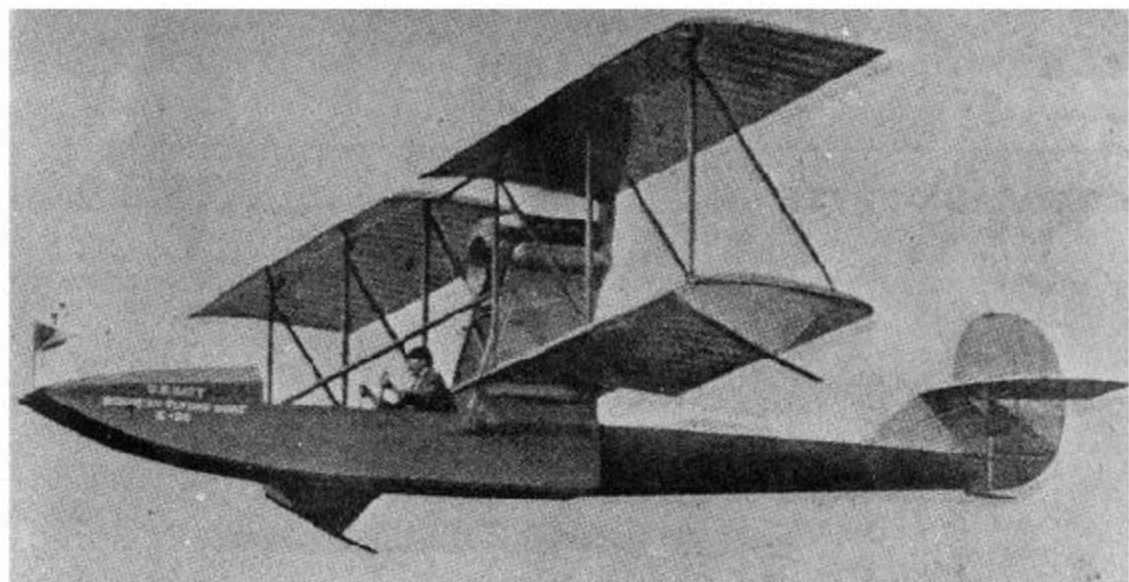

Burgess-Curtis. 1913 Naval flying boat.

C

## CHRISTMAS.

Durham Christmas Aeroplane Sales & Exhibition Corporation, Inc. 1913. Capital: \$10,000 to \$50,000. Claims for it are that it is "automatically balanced." This is attained by the shape of the machine, not through the agency of any auxiliary apparatus.

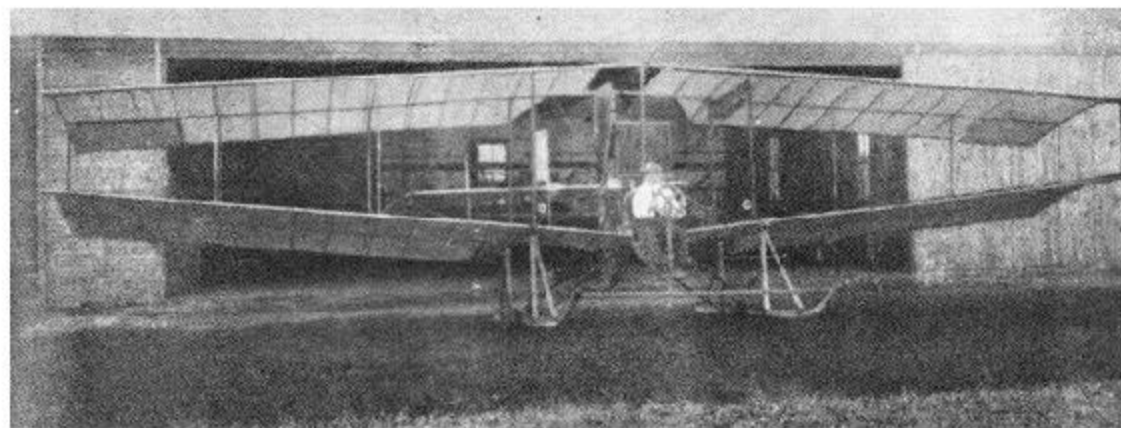

## CORDEAUX-ETTER.

Cordeaux-Etter Mfg. Corporation, Brooklyn, N.Y. Capital: \$10,000. Took over, 1913, the Aeronautical Supply Co., of N.Y.

## COOKE.

Weldon B. Cooke Aeroplane Co., Sandusky, Ohio. Founded 1913 by the well-known aviator, W. B. Cooke.





Model and date.		1913.
Length	feet (m.)	25 (7.60)
Span	feet (m.)	24 (7.30)
Area	sq. feet (m <sup>2</sup> .)	240 (22)
Weight	total lbs. (kgs.)	750 (340)
	useful lbs. (kgs.)	...
Motor	h.p. {	75 Roberts 2 cycle <i>upside down</i>
Speed	m.p.h. (km.)	...
Number built during 1912		new firm

Details, *Aeronautics*, U.S.A., February, 1913.

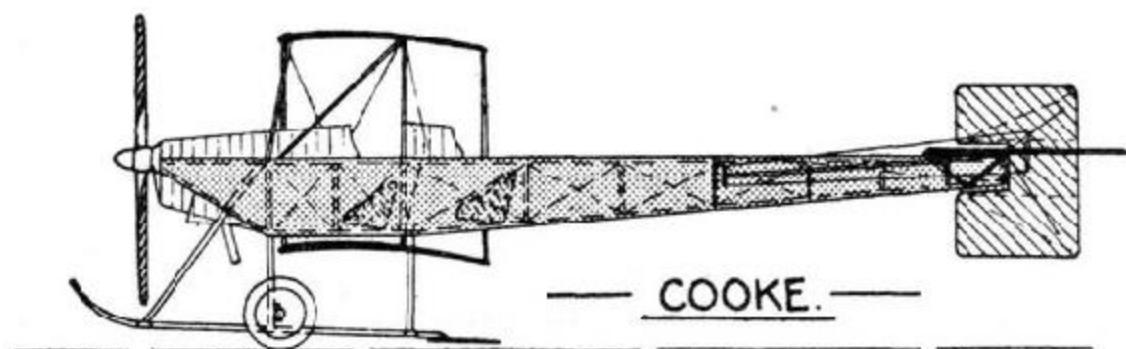

COOKE. Uniform Aeroplane Scale

## CURTISS.

Curtiss Aeroplane Co., Hammondsport, N.Y. Glenn H. Curtiss in 1907 and 1908 was a member of the Aerial Experiment Association, formed by Dr. and Mrs. Alexander Graham Bell. This Association built four machines, each along the lines of one of the four engineers belong to the Association, F. W. Baldwin, Lieut. T. E. Selfridge, G. H. Curtiss and J. A. D. McCurdy. The last built was the *June Bug*, designed by Curtiss and was the most successful. In the spring of 1908, the Association was disbanded and The Aeronautical Society gave Curtiss an order for an aeroplane with *carte blanche* as to design. He produced a 4 cyl. machine, Curtiss engine, and flew it. A duplicate was hurriedly built, 8 cyl. engine installed, and taken to Europe for the first Gordon Bennett, which he won. Returning, the same type was continued with minor improvements. Later the front elevator was brought closer in, finally discarded, and the fan tail adopted and this remains the standard land machine to-day. In April, a military tractor was built and flown.

On January 26th, 1911, first successful flights were made with a hydroaeroplane, at the Winter camp at San Diego, Calif. This had two floats tandem. One was finally adopted and great success was achieved, and remains standard at the present time. With this machine various experiments were made. It was altered in a tractor for one occasion, it was lifted on board warships; made into triplane, etc.

In 1912 he brought out his present type of flying boat. This is being rapidly developed and minor changes in details are made in practically every machine put out.

In May, 1913, he produced a special 4-passenger flying boat for a customer on special order.

*Note.*—In addition to those tabulated, special small racing machines have been built, as well as similar machines with extra sections simply added either side for Army use.

Model and date.		Type D. 1913.	Type E. 1913.	Type F. 1913.
Length	feet (m.)	26-2/3 (8.10)	27-1/3 (8.33)	27-1/3 (8.33)
Span	feet (m.)	26-1/4 (8)	31-1/4 (9.50)	38-1/3 (11.70)
Overall	feet (m.)	33-1/12 (10)	36-1/4 (11)	41-2/3 (12.70)
Area	sq. feet (m <sup>2</sup> .)	214 (19-1/2)	288 (26-1/4)	421-1/2 (39)
Weight	total lbs. (kgs)	...	1700 (771)	...
	useful lbs. (kgs)	...	500 (227)	...
Motor	h.p.	Curtiss	80 Curtiss	Curtiss
Speed	m.p.h. (km.)	...	59 (95)	...
<i>Remarks.--</i>		Land service, but is also made fitted with floats. Panels.	Fitted either with wheels, pontoons, or boat. <i>Vilas boat.</i> Boat 24 ft. long. Beam 54-1/2 ft. long. Height 41 ins. long. Cockpit 3 ft. long by 4 ft. 2 ins. wide.	Used to date only as military tractor or heavy flying boat. <i>McCormick boat.</i> Boat 25 ft. long 4 ft. wide. Freeboard 46 ins. Cockpit 84 ins. long by 46 ins. wide. Length of tail, incl. elevator 12 feet.

For full details of the tractor (F) see *Aeronautics*, U.S.A., February, 1913.

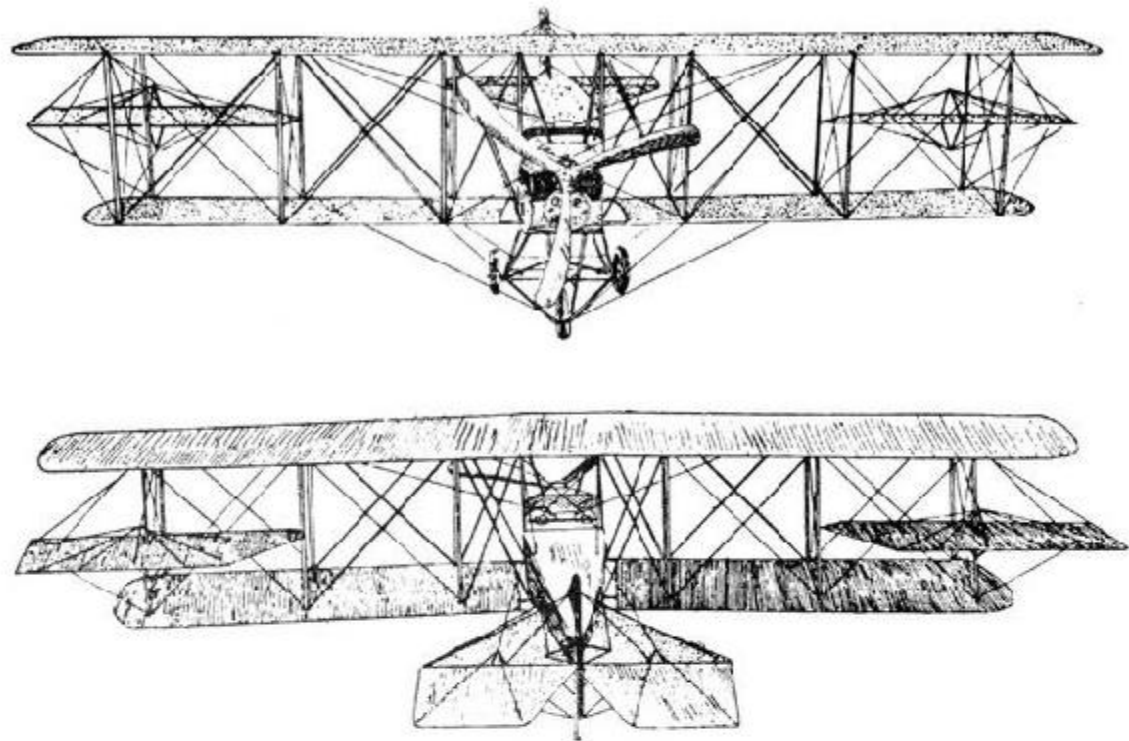

1913 Tractor. Type F.

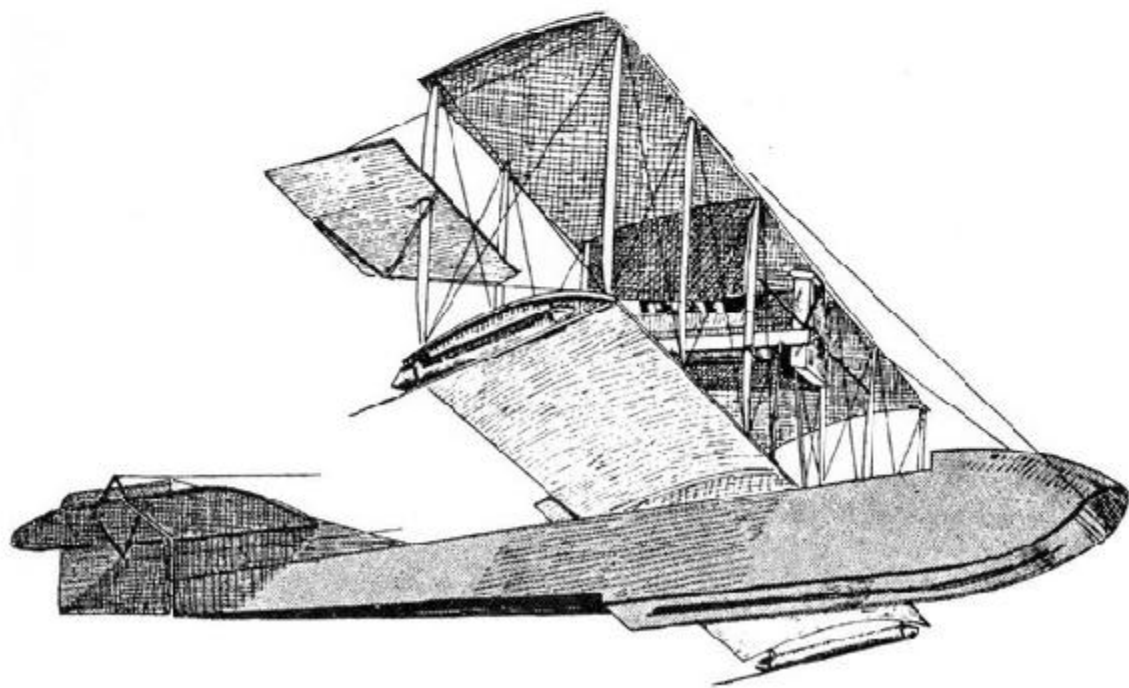

1912 flying boat. *By favor of "Aeronautics," U.S.A.*

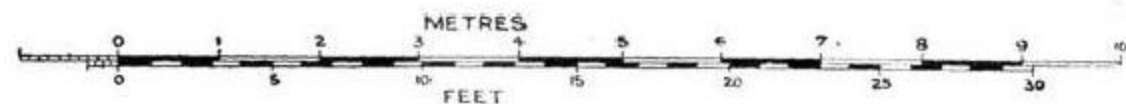
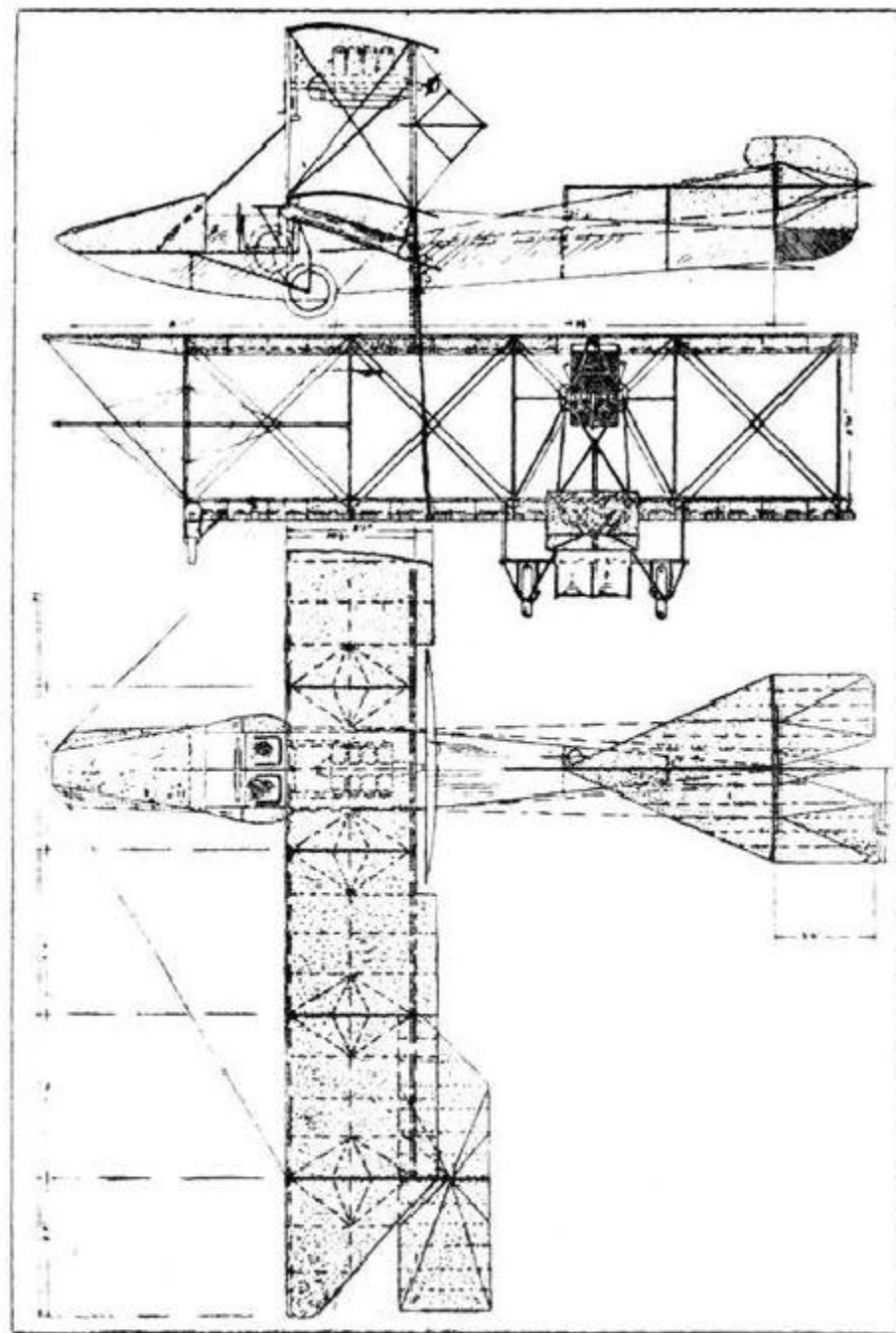

Curtiss. 1913 flying boat. Uniform Aeroplane Scale

## G

### GALLAUDET.

Gallaudet Eng. Co., Norwich Ct.

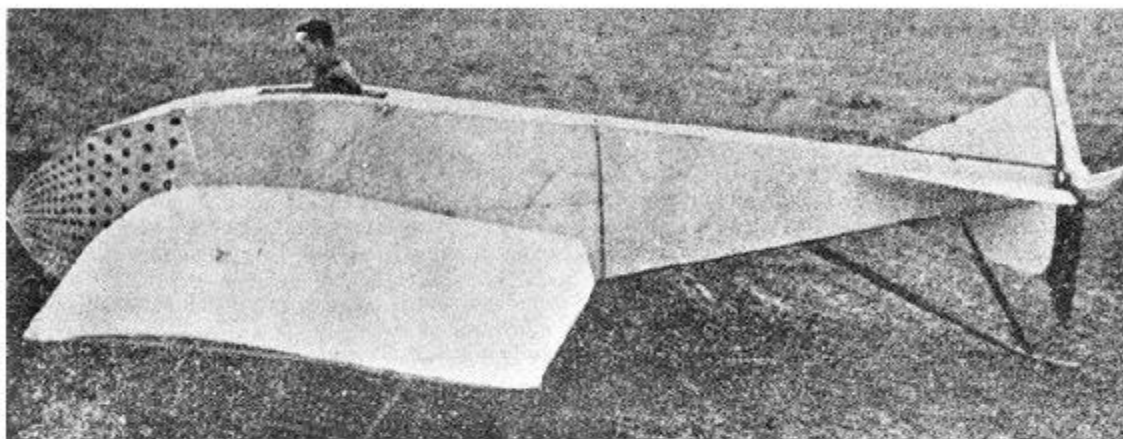

In 1912 produced a special racer as above. **Span**, 32 feet (9.75 m.) **Area**, 200 sq. feet (18½ m<sup>2</sup>.) **Speed**, 100 m.p.h. (160 k.p.h.) **Motor**, 100 Gnome.

## K

### KIRKHAM Biplanes.

Chas. B. Kirkham, Motor Manufacturers, Savona, N.Y. Began to manufacture aeroplanes in 1912, after previous experiments and flights near his factory.

**Length**, feet (m.) **span**, 34 feet (10.40 m.) **surface**, sq. feet (m<sup>2</sup>.)

**Weight**.—Complete, *without pilot*, 980 lbs. (445 kgs.)

**Motor**.—50 h.p. Kirkham, located in front under bonnet. 70 h.p. also fitted.

**Speed**.—56-62 m.p.h. (90-100 k.p.h.)

**Remarks**.—Rises easily at under 35 m.p.h., and has a full speed radius of 5½ hours. Full details in *Aeronautics*, U.S.A., January, 1912. 1913, no changes.

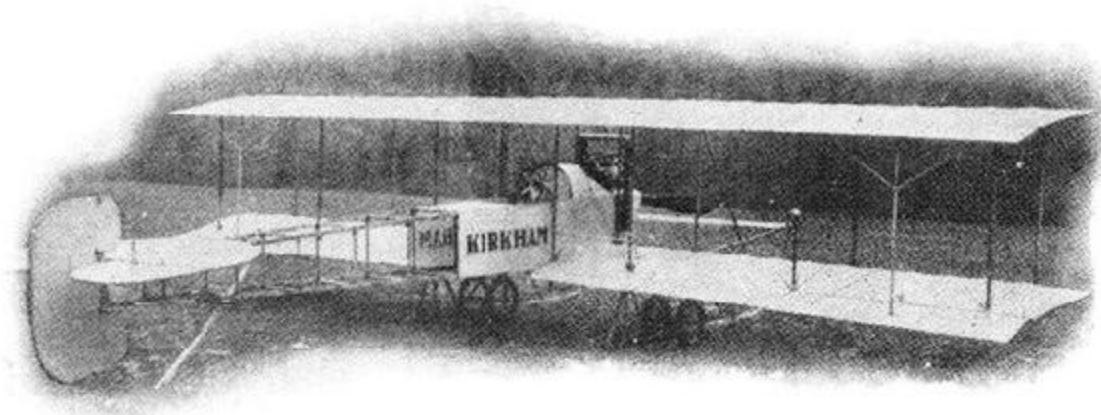

## L-S

### LOENING.

Monoplane aero boat, with one very deep step. See *Aeronautics*, U.S.A., May-June, 1912.

### SELLERS. Quadruplane.

Matthew B. Sellers, R.F., D2, Norwood, Ga. Has been successfully experimenting for a number of years with a staggered quadruplane, and has given the aviation world a number of valuable papers. His aim is to fly successfully with the least possible horse power. For several years he has been making flights with various engines delivering from 5 to 6 h.p. on careful test. The actual thrust has been measured and recorded in late 1911 experiments. Details in *Aeronautics*, June, 1909; October, 1909; November, 1910; January, 1911; January, 1912. No actual details of the machine are available, but it follows closely the patent drawings (see references). He is one of the few real scientific flying men in the U.S.A. The original machine with slight changes was still flying at end of 1912 with only 5 h.p. B.H.P. The flying speed is 20 m.p.h.

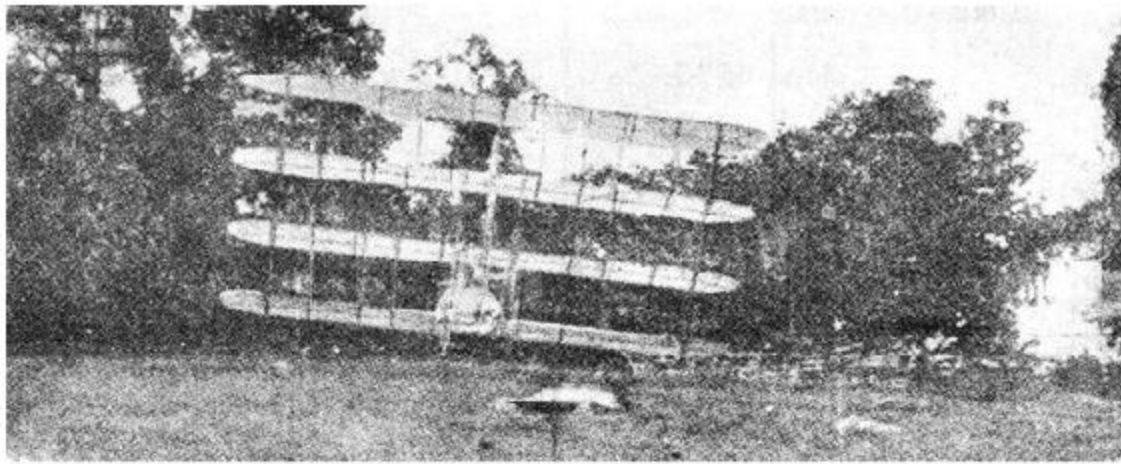

## SLOANE.

Sloane Aeroplane Co., 1733, Broadway, New York. Established 1911. Agents for *Caudrons* and *Deperdussins*. Run a school for these.

## T-V

## THOMAS Biplanes.

Thomas Bros., Bath, N.Y., O.W., and W.T. Thomas began experimenting and flying in 1908 with a machine on the order of a *Curtiss*. In the winter of 1909-10, a type of their own was produced and was flown during 1911 by Walter Johnson in exhibitions. In 1912 they continued the same type, with refinements. In 1913 they adopted the overhanging top plane type, but of the same general high order of construction.

Model and date.		1912. Tractor biplane.	1913. Monoplane.	1913. Standard biplane.	1913. Special biplane.	1913. Flying boat.
Length	ft.(m.)	...	30 (9.15)	...	25 (7.62)	...
Span	ft.(m.)	37 (11.27)	32 (9.75)	37 (11.27)	33 (10)	33 (10)
		27 (8.23)	...	27 (8.23)	23 (7)	23 (7)
Area	sq. ft. (m <sup>2</sup> .)	...	...	...	...	...
Weight	total lbs. (kgs.)	900 (408)	750 (340)	900 (408)	850 (385)	...
	useful lbs. (kgs.)	...	...	...	400 (181)	...
Motor	h.p.	65 Kirkham	70 Kirkham <i>muffled</i>	65 Kirkham	65 Kirkham	100 Maximotor
Speed	m.p.h. (km)	58 (94)	...	58 (94)	60 (97)	...
Endurance	hrs.	2	...	2	2-1/4	...
Number built during 1912		1	building	...	...	building

*Remarks.* Control in all: Ailerons, 4 rudders. Elevator operated by rocking post on which wheel is mounted. The 1912 tractor was given up as less efficient than the Standard 1913. Special: full description *Aeronautics*, U.S.A., May, 1913.

The move was evolved 1912, but not built till well into 1913.

W

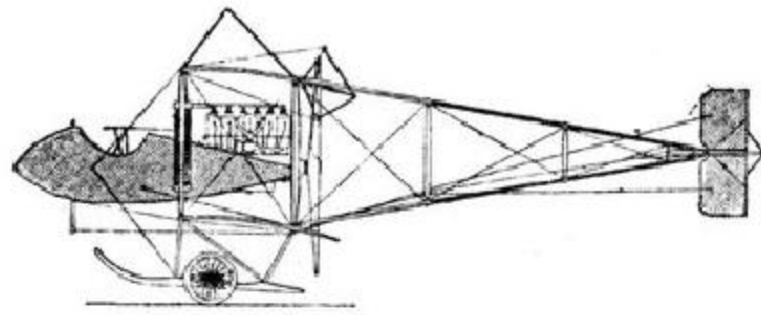

WASHINGTON.

Washington Aeroplane Co., Washington, D.C. In 1913 built a flying boat to private order. **Length**, 29 feet (8.83 m.) **Maximum span**, 38 feet (11.85 m.) **Motor**, 80 h.p. Gyro. Boat with eight compartments and one 3 inch step.

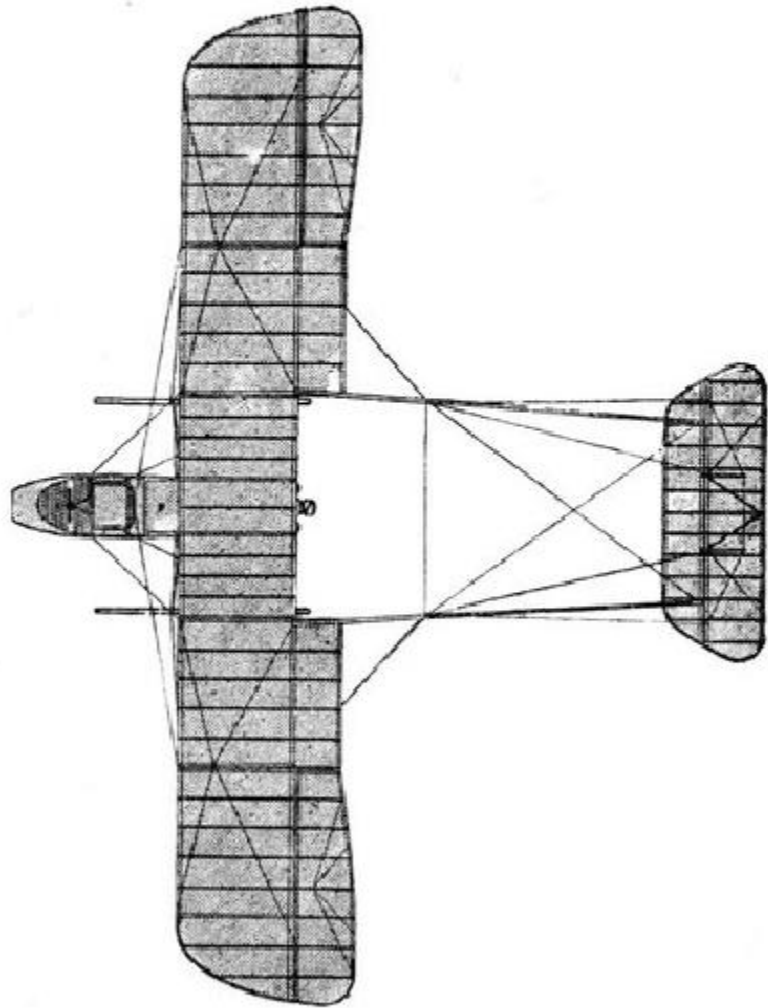

1913 Standard biplane.

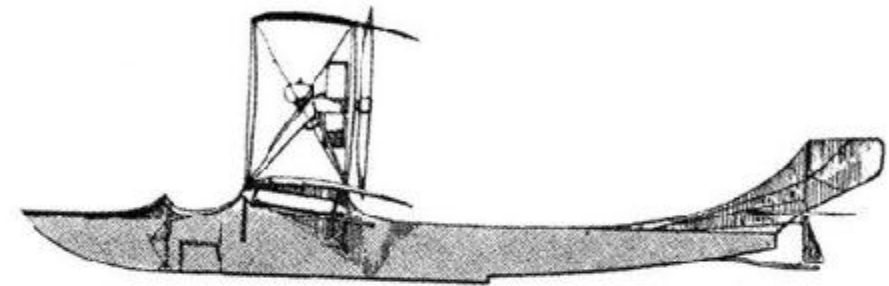

MISS COLUMBIA.

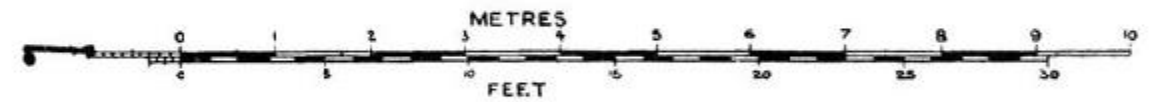

Miss Columbia. Uniform Aeroplane Scale

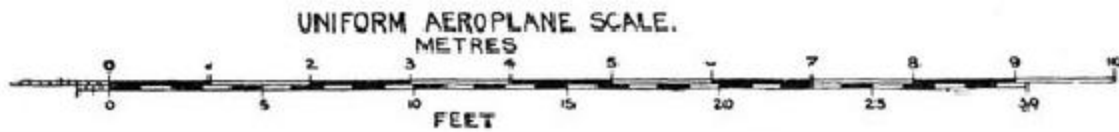

UNIFORM AEROPLANE SCALE.

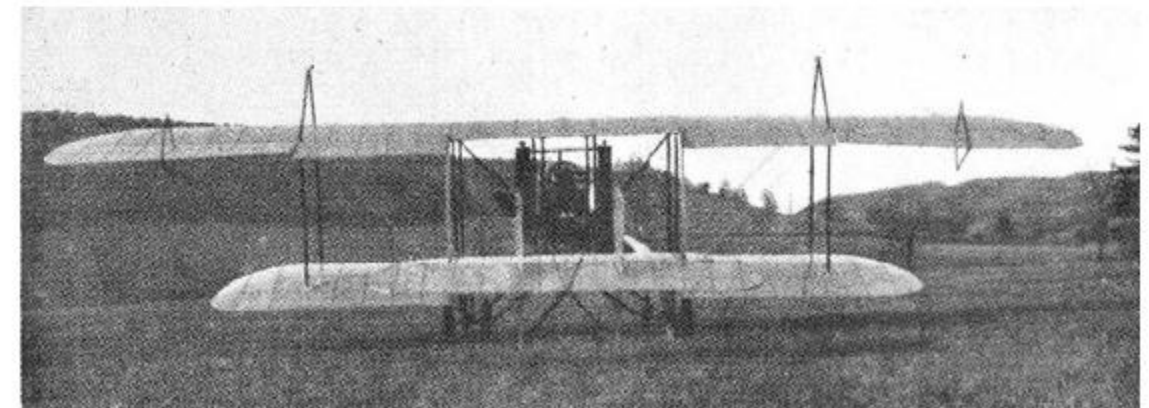

Latest Thomas.

## WITTEMAN.

Witte man Bros., 17, Ocean Terrace and Little Clare Road, Staton Island, N.Y. These people do a considerable business building Curtiss type machines or machines to special designs for others. They built the *Baldwin* biplanes for Captain Baldwin, to his design, using steel tubing throughout. See *Aeronautics*, December, 1911, for a *Witte man* of special design shown by them at the Aero Show.

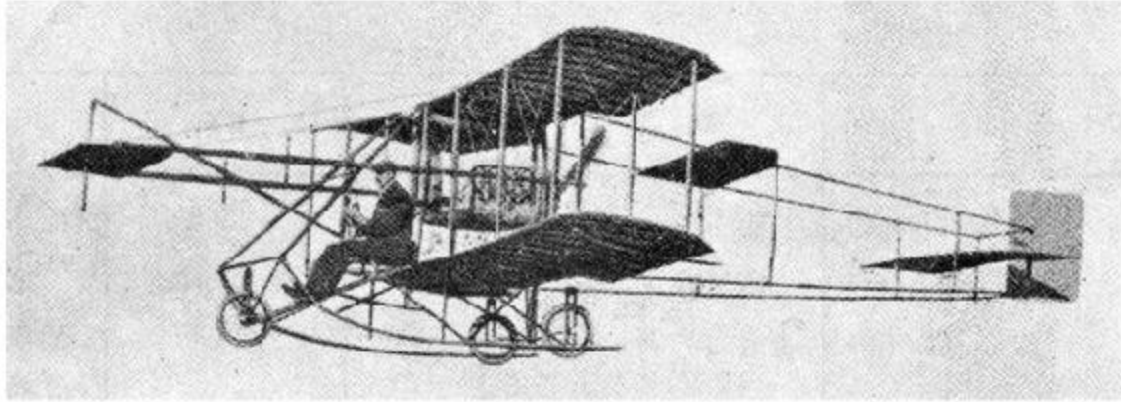

Witte man. 1912-13.

## WRIGHT BROS. Biplanes.

The Wright Co., Dayton, Ohio. The original type of *Wright* machine was mounted on skids only, and started along a rail. Its special features were a biplane elevator forward, main planes with warpable tips to trailing edge, small keel in gap, 2 propellers, chain driven in rear of planes, double rudder in rear and no tail. Wilbur Wright flew a machine of this type for 2 h. 20 m. 23½ s. in 1908. (Details of early *Wrights* see previous editions of this book.)

Model and date.		B.	C.	EX.	E.
Length	feet (m.)	31 (9.45)	29-3/4 (9)	...	...
Span	feet (m.)	39 (11.90)	38 (11.58)	32 (9.75)	32 (9.75)
Area	sq. feet (m <sup>2</sup> .)	500 (47)	500 (47)	...	...
Weight	total lbs. (kgs.)	1250 (567)	...	...	...
	useful lbs. (kgs.)	...	...	...	...
Motor	h.p.	30-35 Wright	30-35 Wright	30 or 50 Wright	30 or 50 Wright
Speed	m.p.h. (km.)	45 (75)	45 (75)	...	...
			1913 standard. This machine as a hydro is fitted with two 3 step floats. Mea magneto.	For exhibition work only. Single seater small duplicate of B.	1913 for exhibition work only. Single seater duplicate of EX except fitted with a single propeller only.

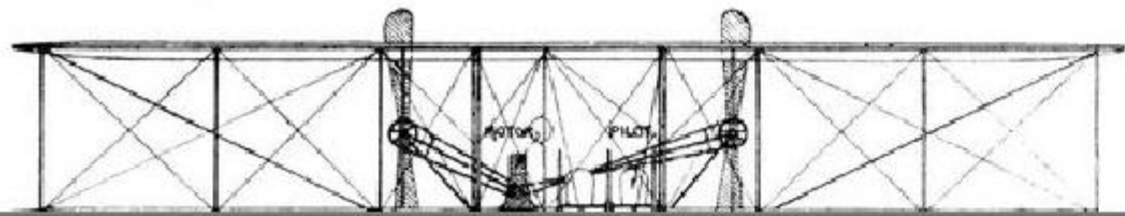
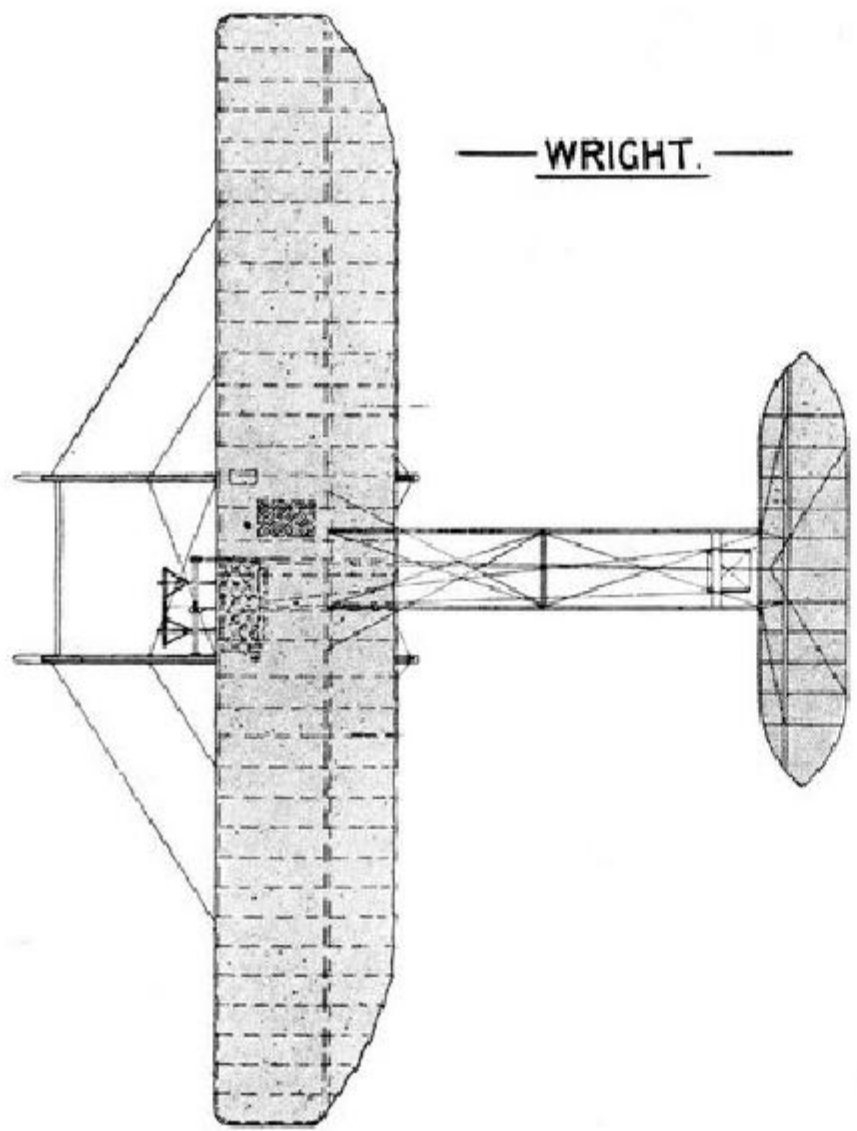
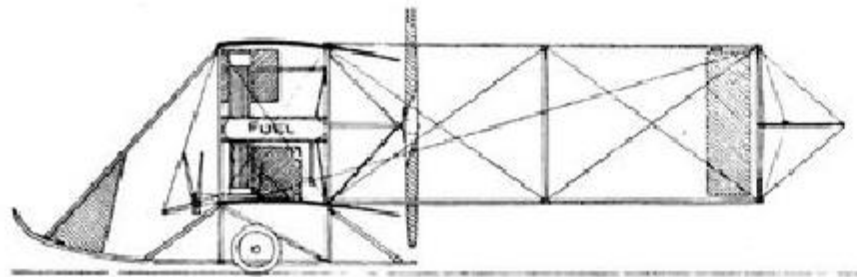

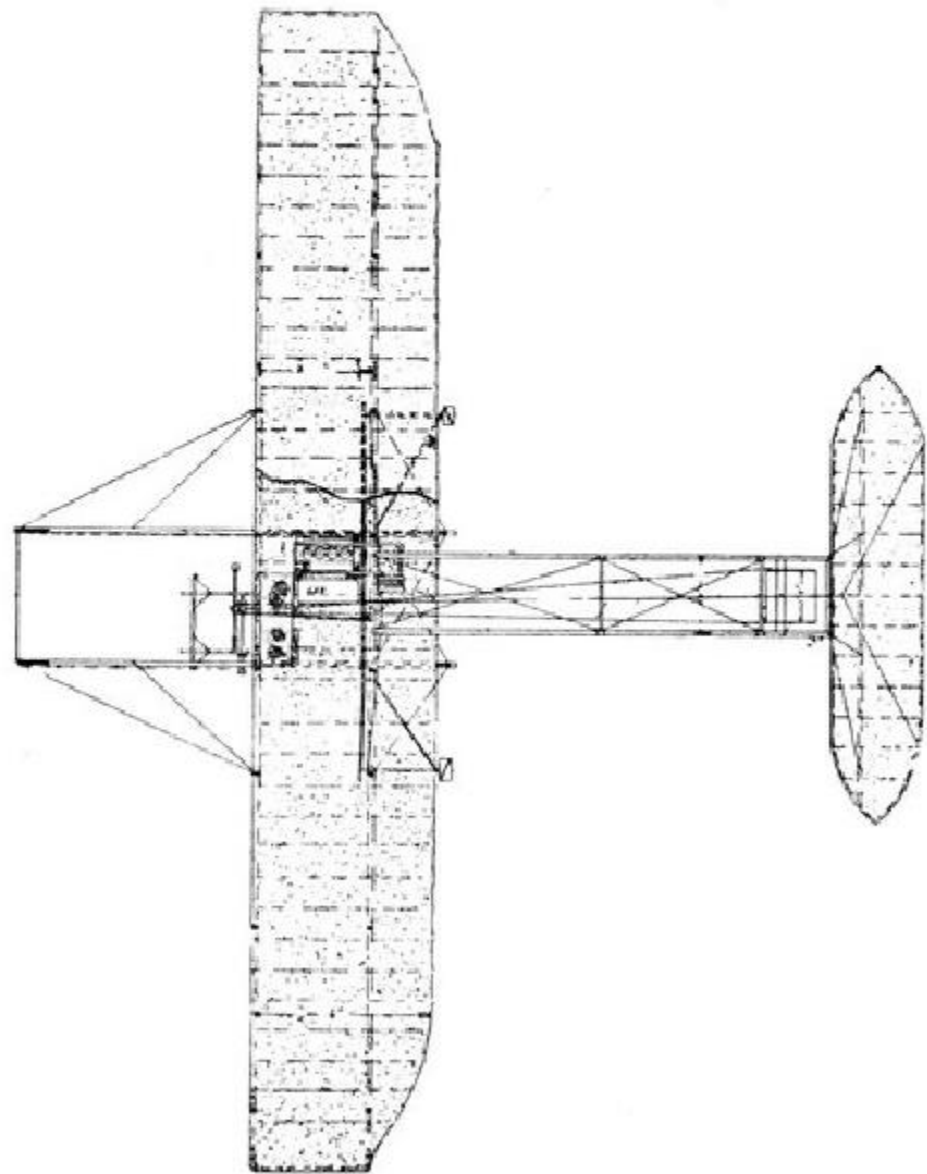
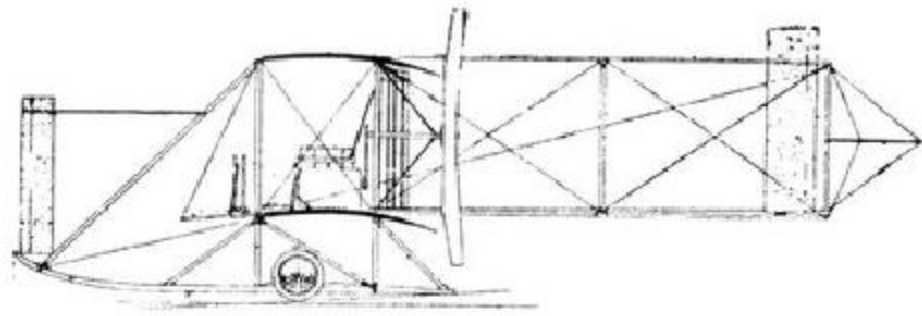



## U.S.A. DIRIGIBLES.

Part B.

There are a few small dirigibles in the U.S.A., but they are in no way to be compared to French and German productions. Up-to-date, they have only been used as attractions at fairs about the country. In the past several larger ones of poor design have been built and found failures.

### **Military.**

#### **BALDWIN**

(1908) 20,000 c. feet (560 m<sup>3</sup>)

## HISTORICAL AIRCRAFT.

In the following pages an attempt has been made to include photographs of all aeroplanes of the past six years, which, for one reason or another, "made history" in their own day.

While many are merely freak machines, which in the light of present knowledge seem ridiculous, the germ of modern practice is to be found in many other aircraft illustrated in this cemetery of dead ideals; and it is worth noting that at least one constructor, who is one of the first in the field to-day, commenced operations with machines which were entirely "freaks."

### AUSTRIAN.

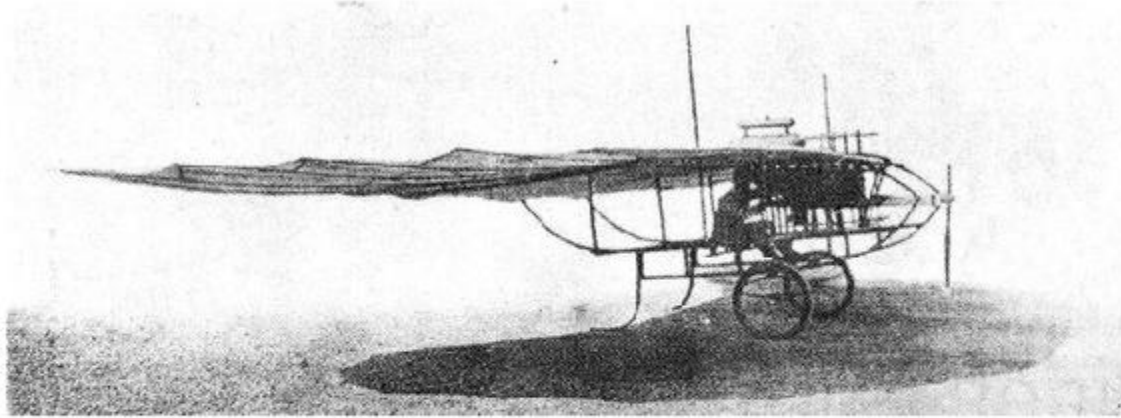

WELS & ETRICH (1908). Original form of the modern *Etrich* (q.v.).

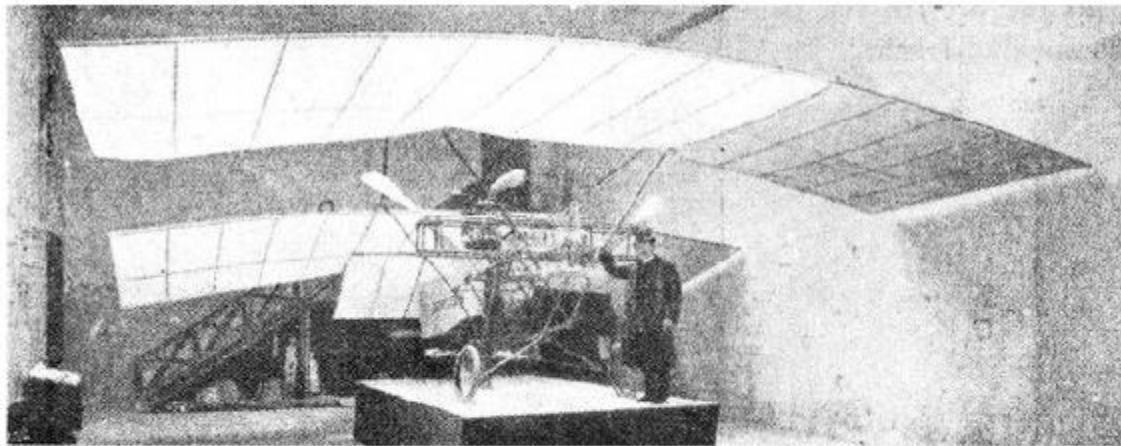

HIPSSICH (1908). Tandem mono. with one propeller before and another in rear of rear plane.

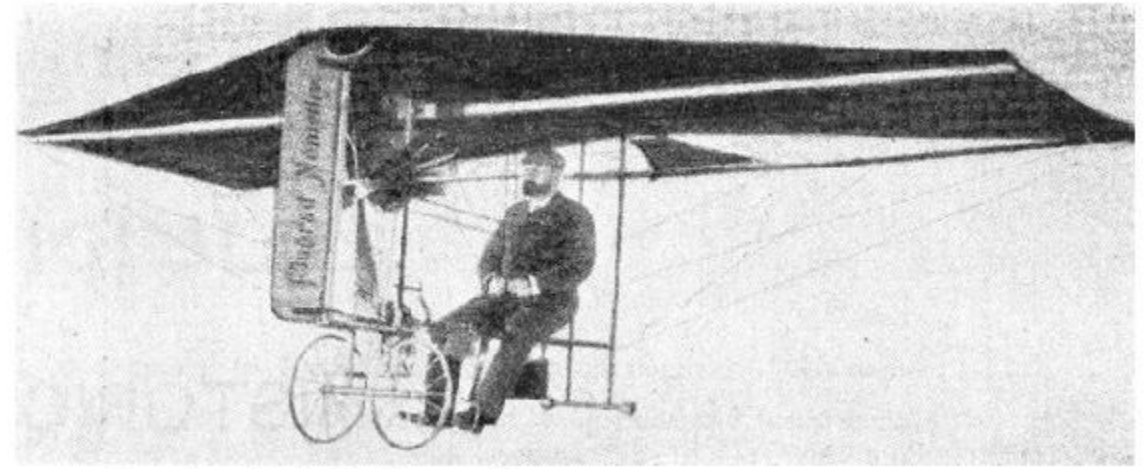

NEMETHY (1908). The first "Aviette."

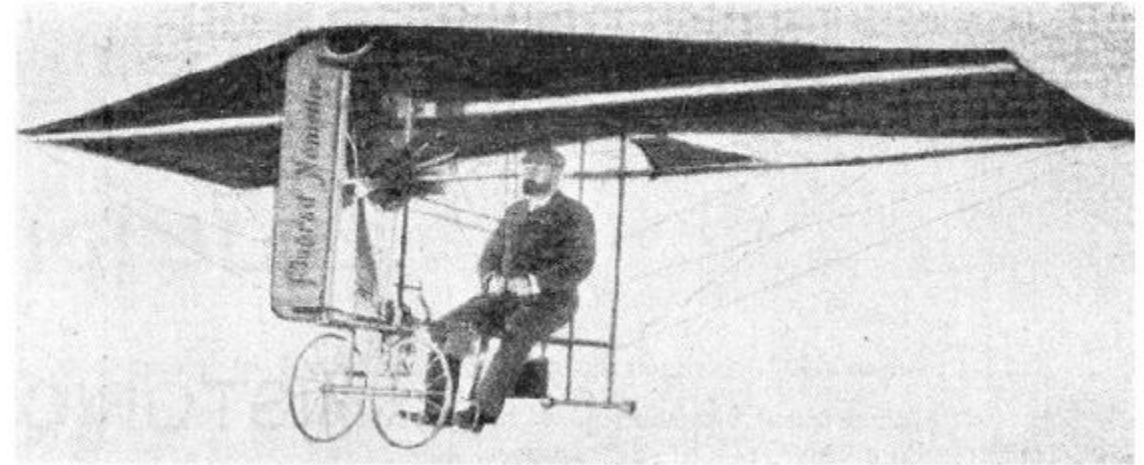

SOLTAU (1910). An ornithopter based on the earlier ideas of *Adhemar de la Hault* (see Belgium).

## BELGIAN.

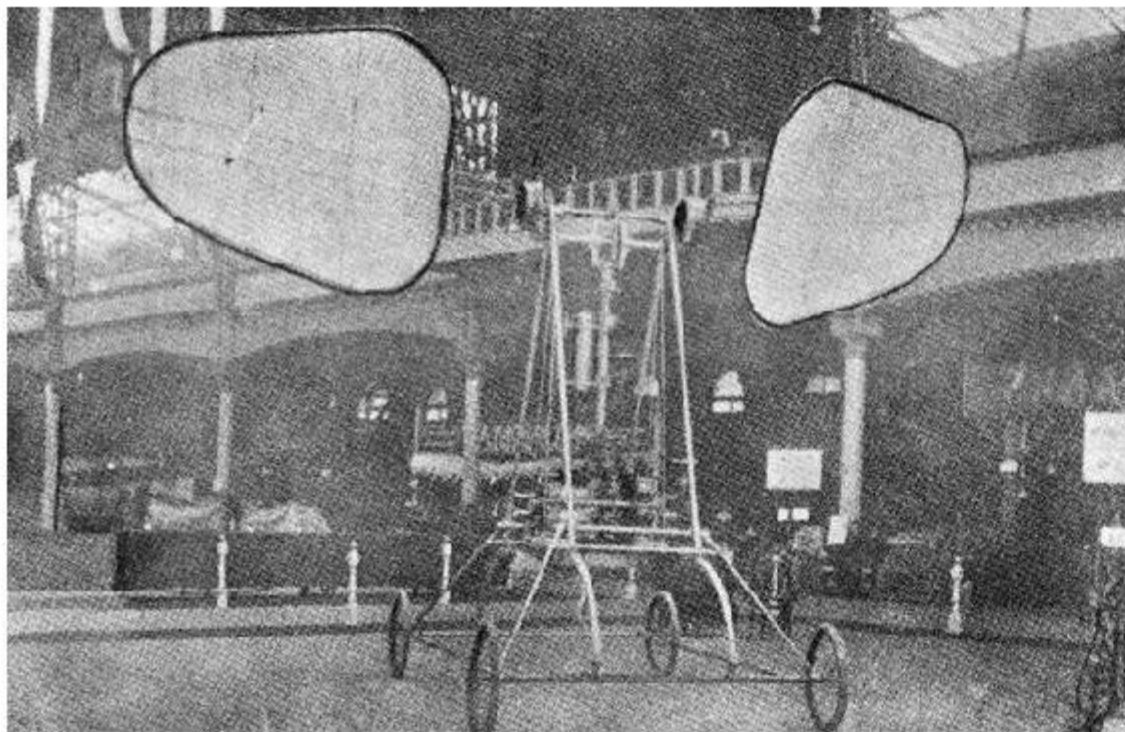

DE LA HAULT (1907). One of the earliest attempts at an ornithopter. No flights.



DE LA HAULT II. (1910-11). The ornithopter principle applied to a monoplane. No success met with.

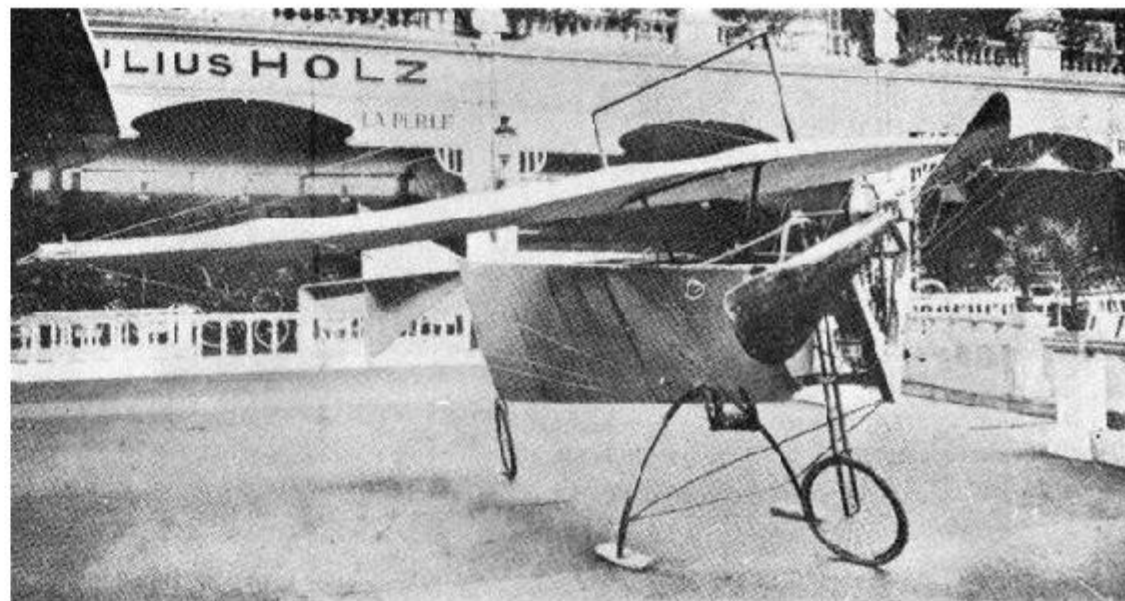

D'HESPEL (1909-10). Single plane and suspended body. Early example of enclosed body. No flights.

## BRAZIL.

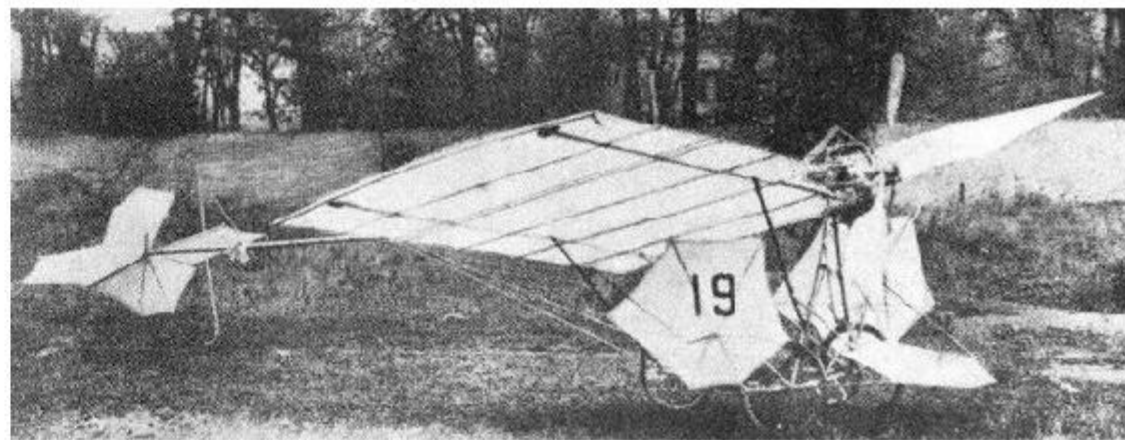

SANTOS-DUMONT XIX. This little machine, surface only 9 m<sup>2</sup>. made an extraordinary sensation in France in 1909. It flew at the then incredible speed of 65 m.p.h. (100 k.p.h.) Santos-Dumont presented all rights to the world soon afterwards, and a large number were built before it was realised that only an extremely light weight pilot could fly in one. Few of the copies ever left the ground.

## BRITISH.

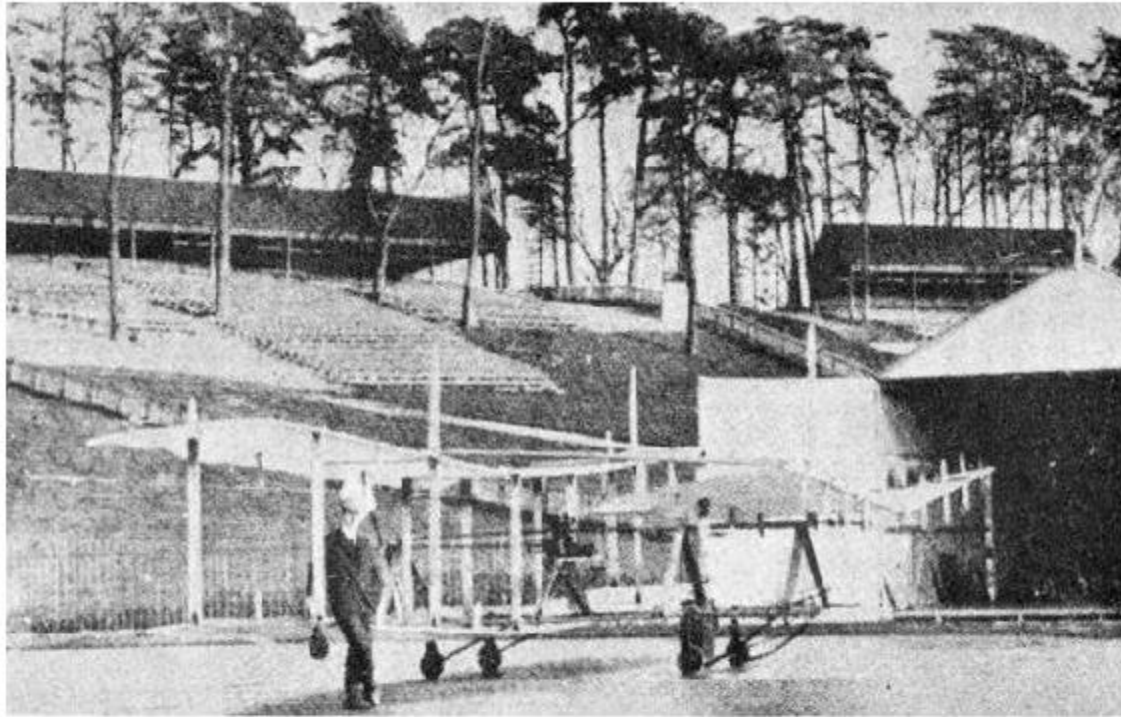

**AVRO (1906).** This 24 h.p. biplane, designed by A. V. Roe, was the first British machine to leave the ground.



**AVRO (1907).** Tractor triplane of only 9 h.p. This flew in Lea Marshes—the lowest horse power yet flown in Europe to the present day.

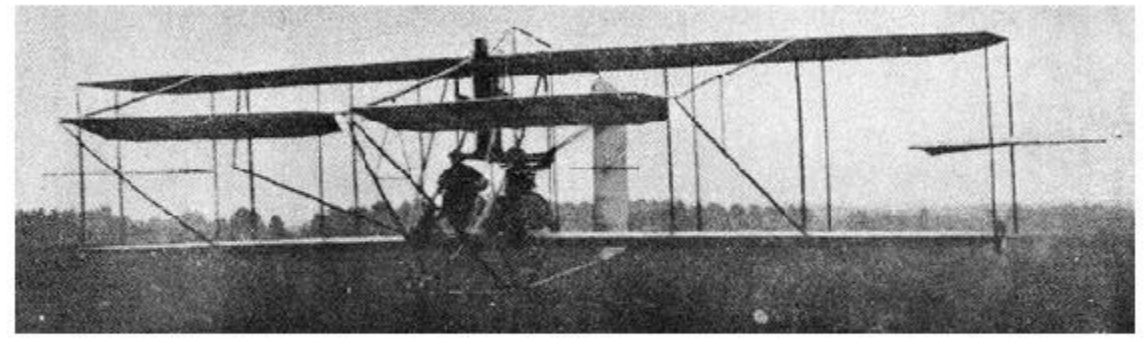

**CODY (1909).** Development of a much earlier machine. This one was a general laughing stock for a long time; but it was the direct predecessor of the machine (not very materially different) which was an easy first in the British Army aeroplane trials, 1912.

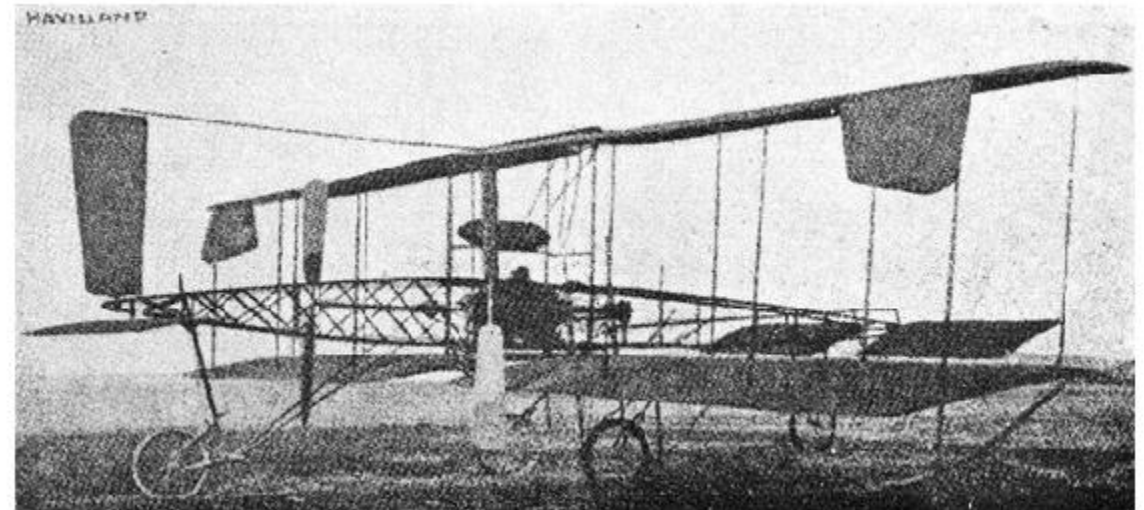

**DE HAVILLAND (1909).** The performances of this machine secured a Government appointment for its aviator-designer.

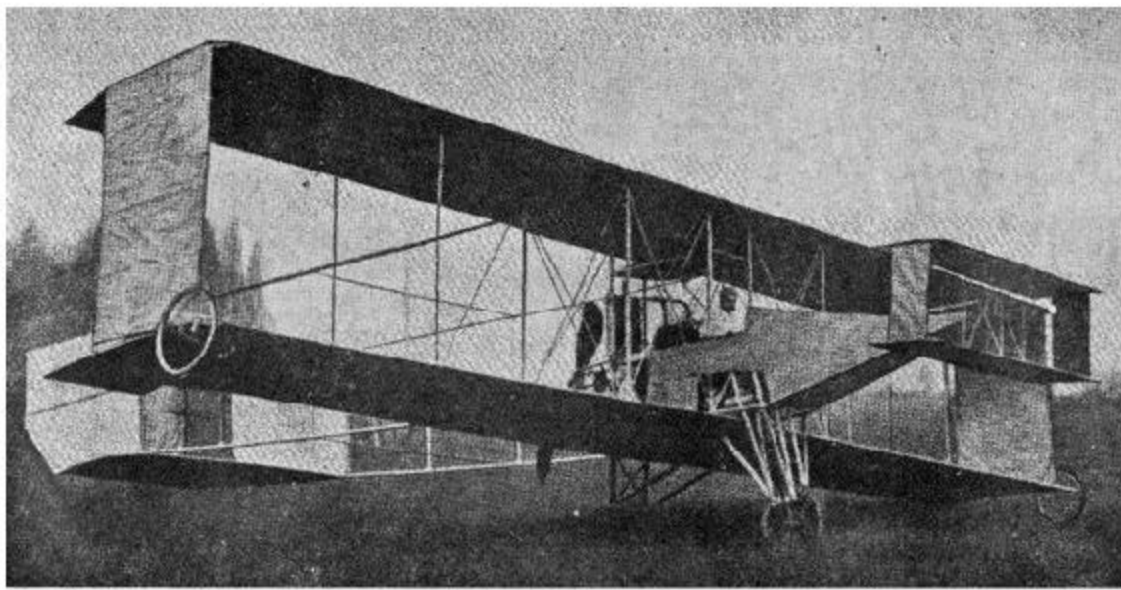

**HOWARD WRIGHT (1908-09).** The first machine in the world in which special attention was paid to securing a stream line body and minimised wind resistance.

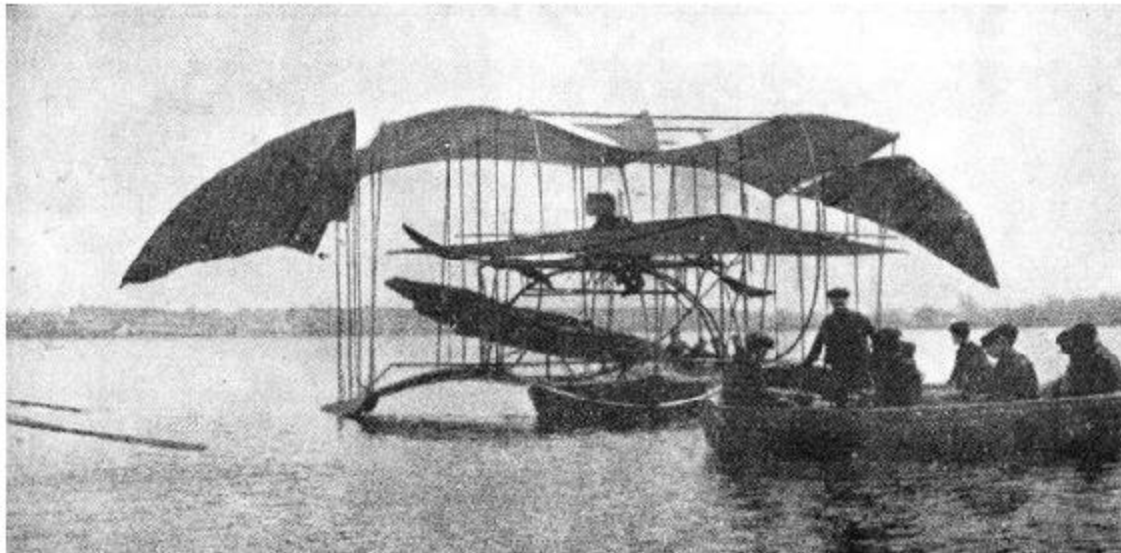

**HUMPHREY (1908-09).** Earliest British attempt at a hydro-aeroplane; possibly the earliest design ever produced anywhere.



**HUNTINGDON (DUNNE II) (1910).** One of the earliest aeroplanes in existence—designed by Captain Dunne about 1905-06, previous to the secret experiments of the British War Office in Scotland, on the Duke of Atholl's estate. Assigned to Prof. Huntingdon in 1910. Made a few short flights.

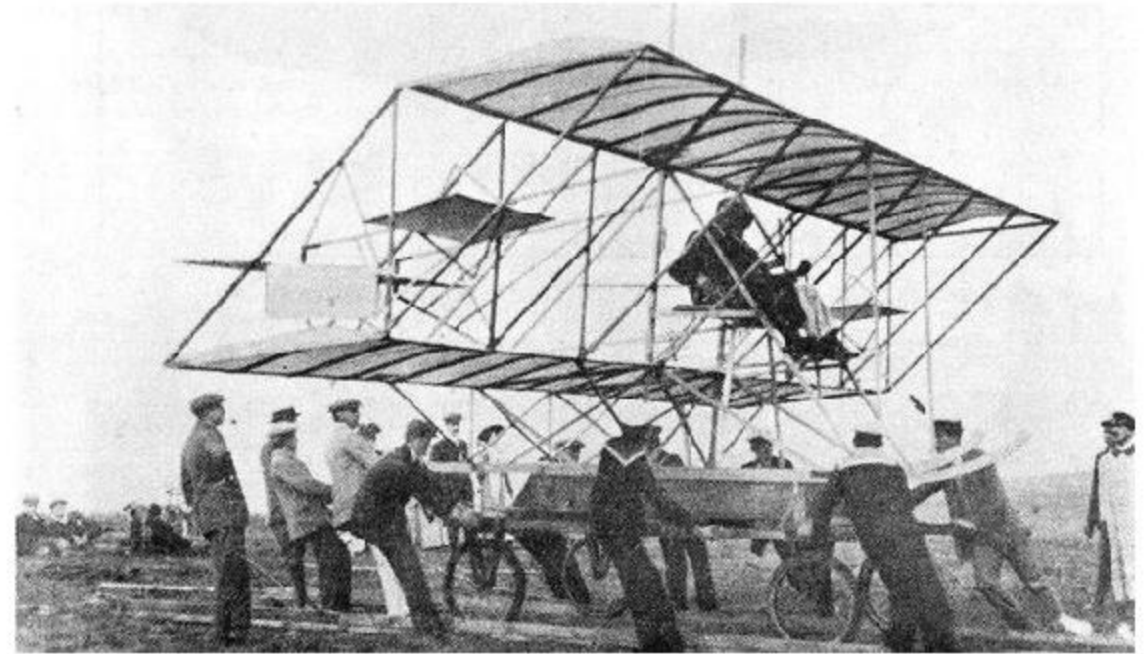

**PORTE (1908).** Designed by Lieut. Porte, R.N., in conjunction with Lieut. Pirrie, R.N. This machine, on which the former well known aviator commenced his flying career, was smashed up in preliminary trials as a glider on Portsdown Hill, Portsmouth. Its design apparently preceded the *Goupy* in the use of staggered planes.

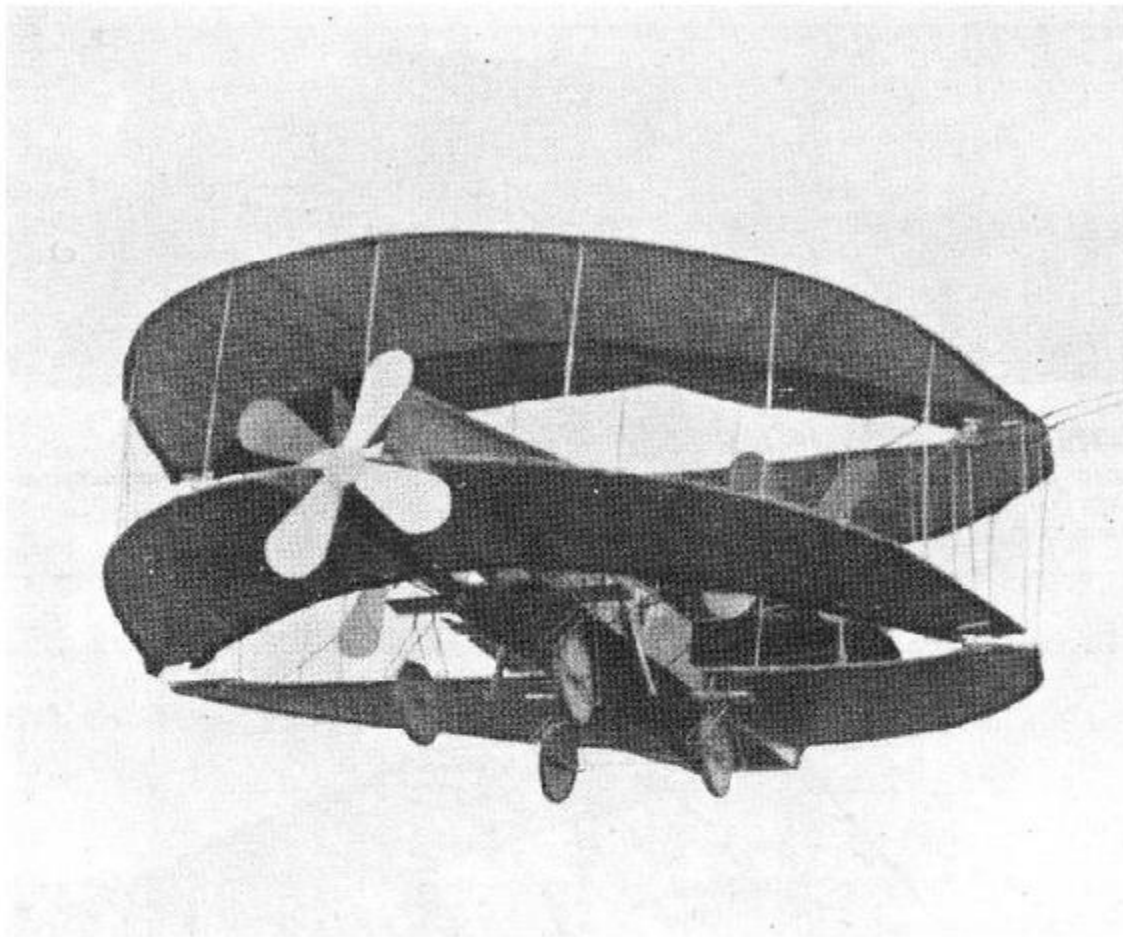

"SAFETY" (1909-10).

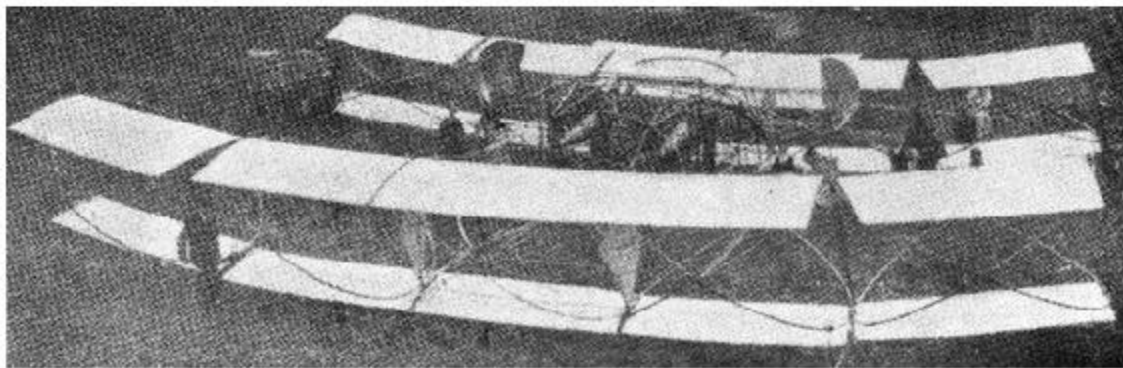

SEDDON. (1910). Designed by Lieut. Seddon, R.N.

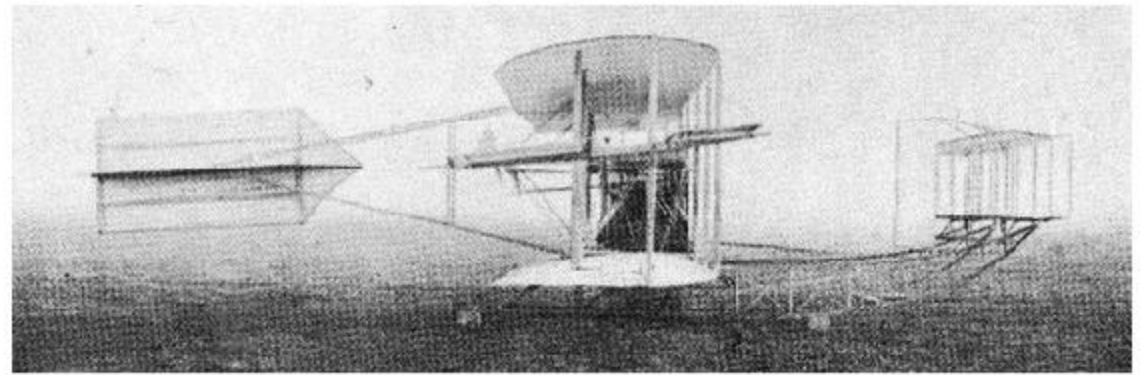

SHORT (1910). The first machine to Short's own design. (The tail here shown is a specially large one fitted by Moore-Brabazon).

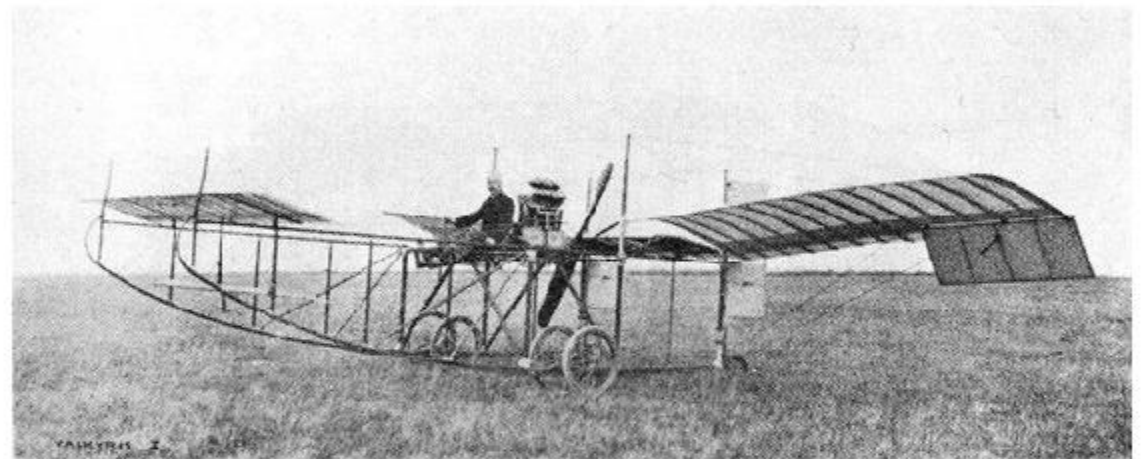

VALKYRIE (1910). This was one of the first "tail first" machines to be designed. The experimental machine (also known as the A.S.L.), was completed in Feb., 1910.

## DANISH.

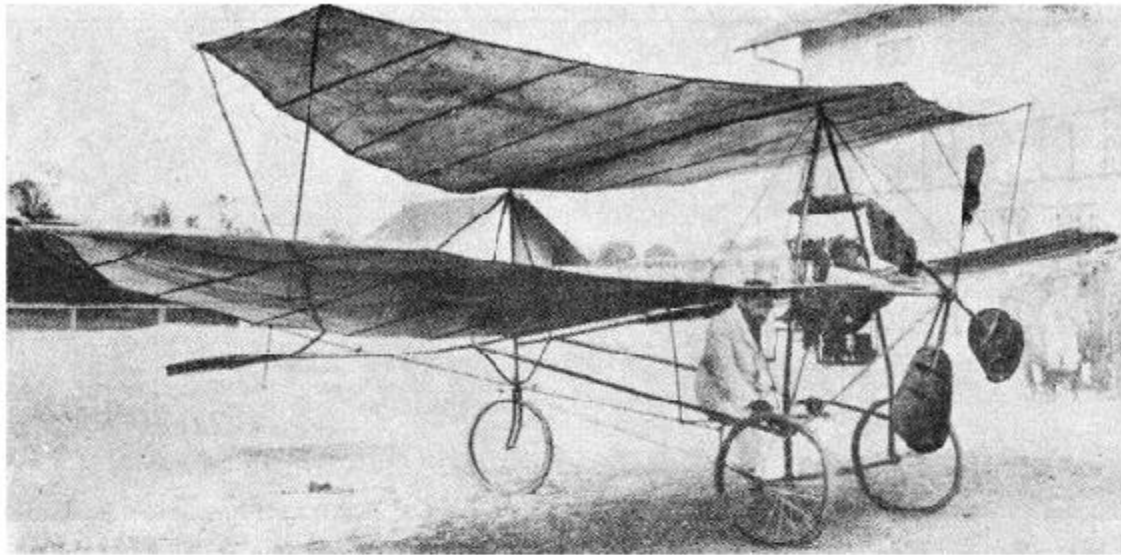

**ELLEHAMMER** (1905). On 12th September, 1906, this machine made the first free flight in Europe. On 28th June, 1908, it won the prize at Kiel for the first flight in Germany (distance, 47 m.) It was a tractor biplane with a revolving Ellehammer motor. It also had a pendulum seat as a stabilising device.

## FRENCH.

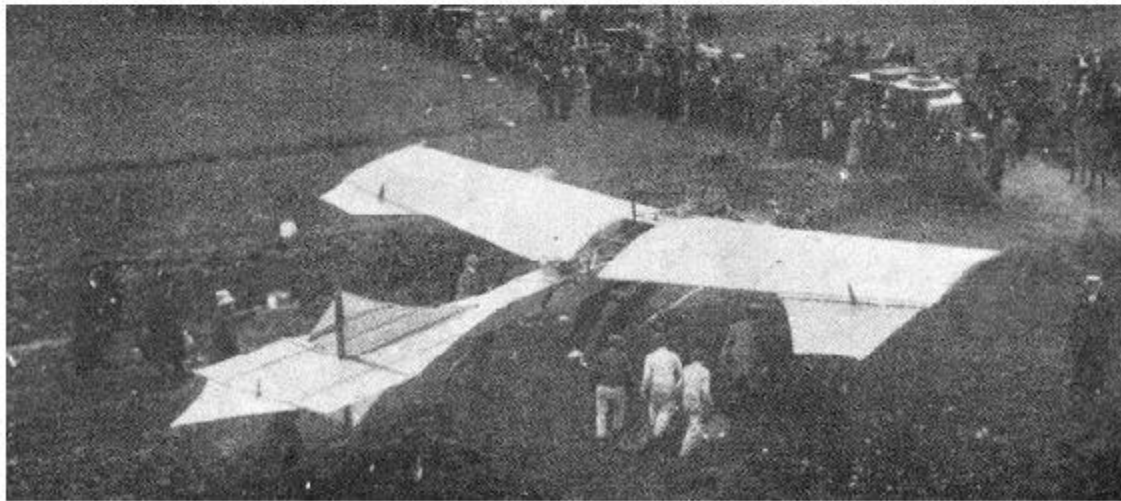

**ANTOINETTE IV** (1909). In this machine Latham made the first attempt to fly the Channel, 19th July, 1909.

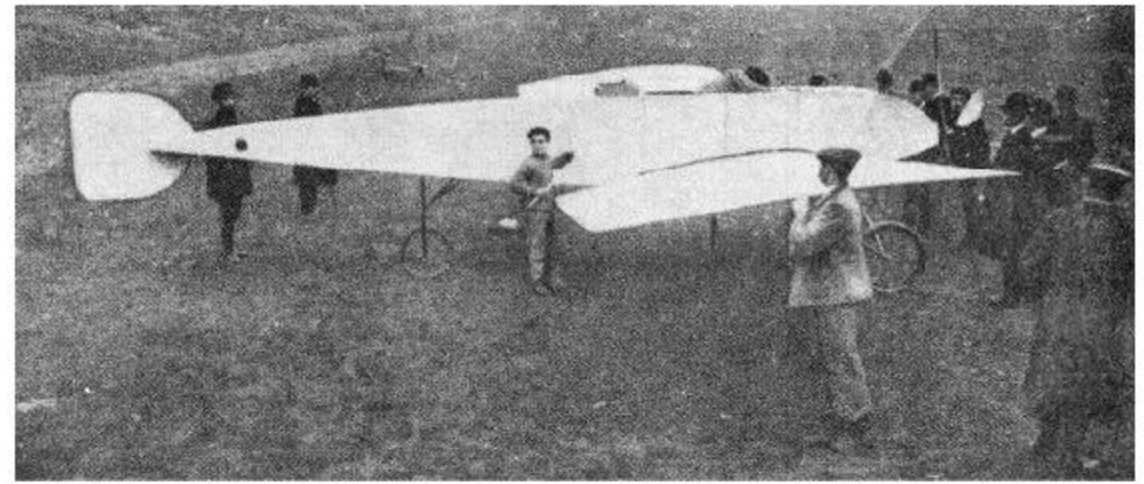

**BLERIOT IV** (1907-8).

In 1909 the famous *Bleriot XI* was built. This did very well at Reims, 1909. On 25th July, 1909, Bleriot made the first Cross-Channel flight in the machine illustrated below.

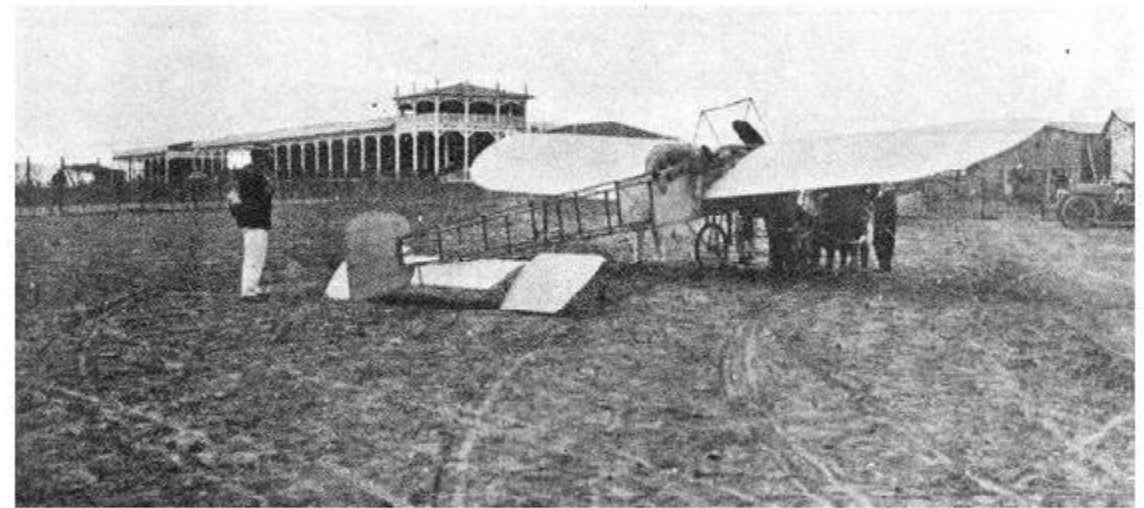

*Bleriot XI.*

This machine had **length**, 23 feet (7 m.) **Span**, 25¾ feet (7.80 m.) **Area**, 167 sq. feet (15½ m².) **Aspect ratio** 4½ to 1. **Motor**, 22-25, 3 cylinder Anzani. **Speed**, about 45 m.p.h. (73 k.m.) *Special features*: Fixed wings with rounded edges. Twin elevator and fixed surface tail.

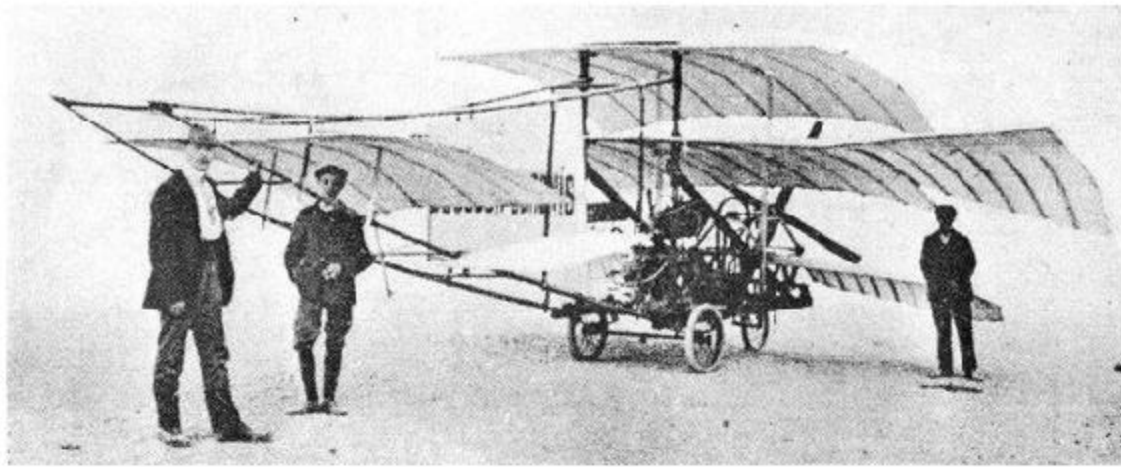

**BOUSSON-BORGNIS (1907-08).**

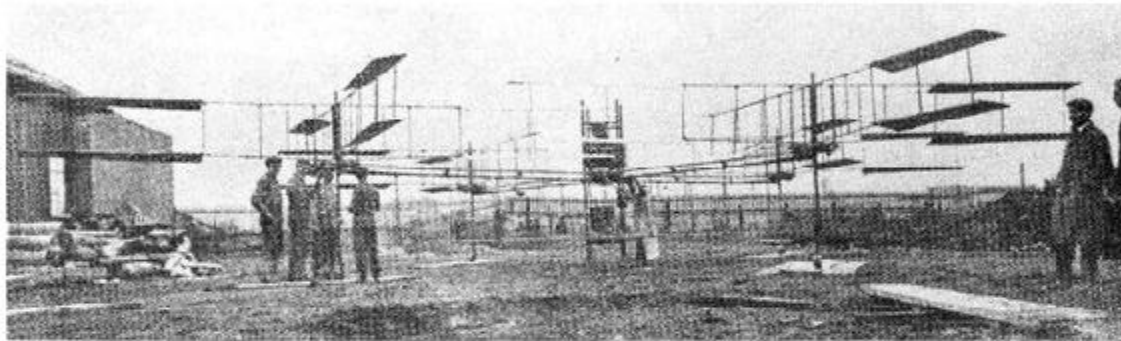

**BREGUET (1906).** The first Breguet, known as *Breguet Gyroplane I*. Made a flight in October, 1906, being the first helicopter to leave the ground.

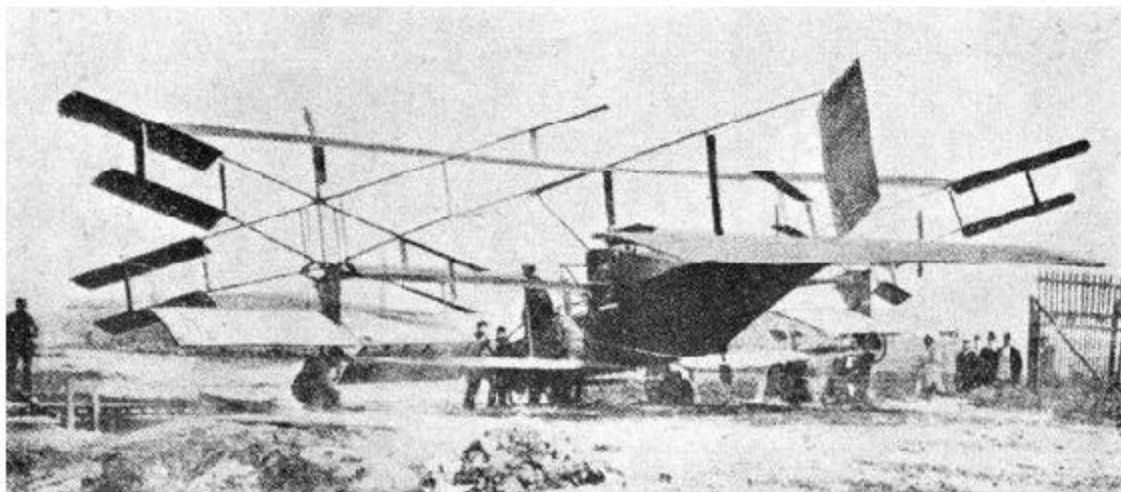

**BREGUET-RICHET II bis. (1909).** A large and unsuccessful development of the gyroplane.

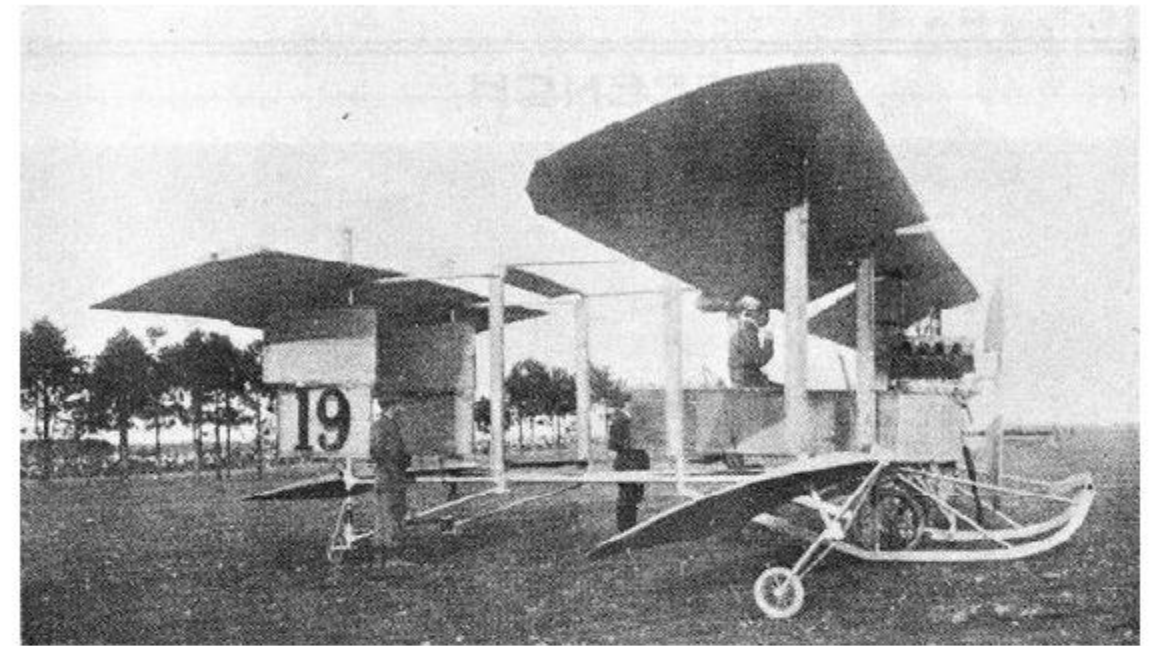

**BREGUET IV (1910).** On its appearance, this machine was generally laughed at and nicknamed the "Coffee Pot," till in Aug., 1910, it made a world's record by carrying six, and later proved itself superior in stability to anything then existing.



**CHAUVIÈRE (1909-10).** Attempt to develop a monoplane with propellers in rear. The idea has been resuscitated for some 1913 military monoplanes.



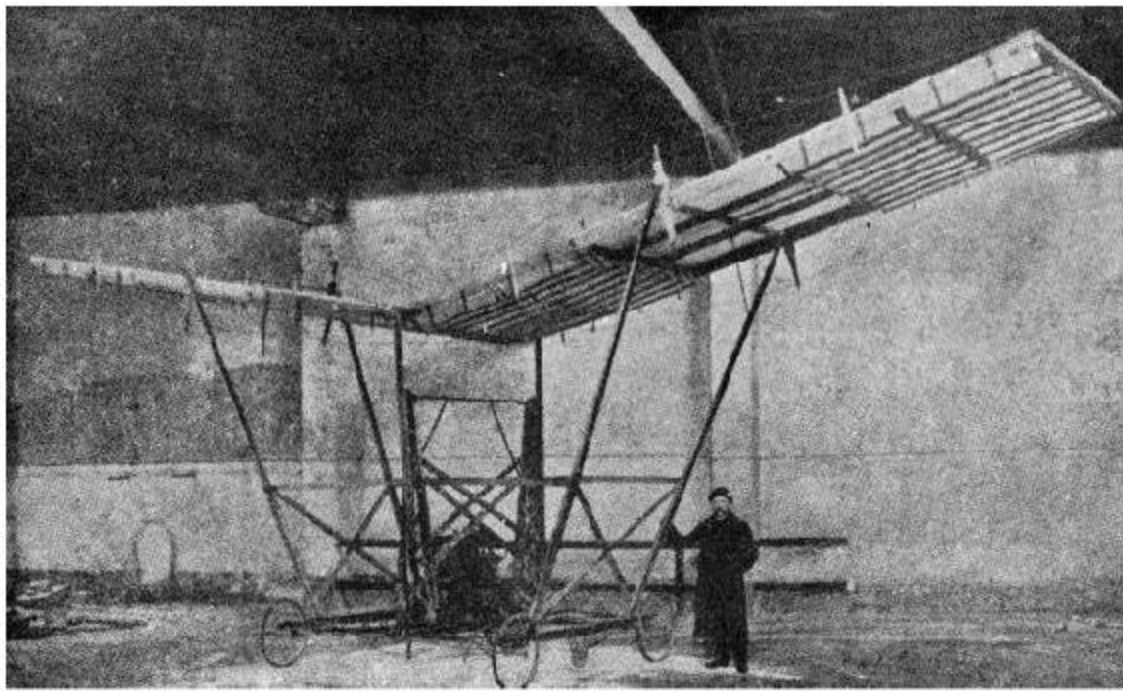

**COLLOMB** (1907-09). Ornithopter, from which great things were once expected.

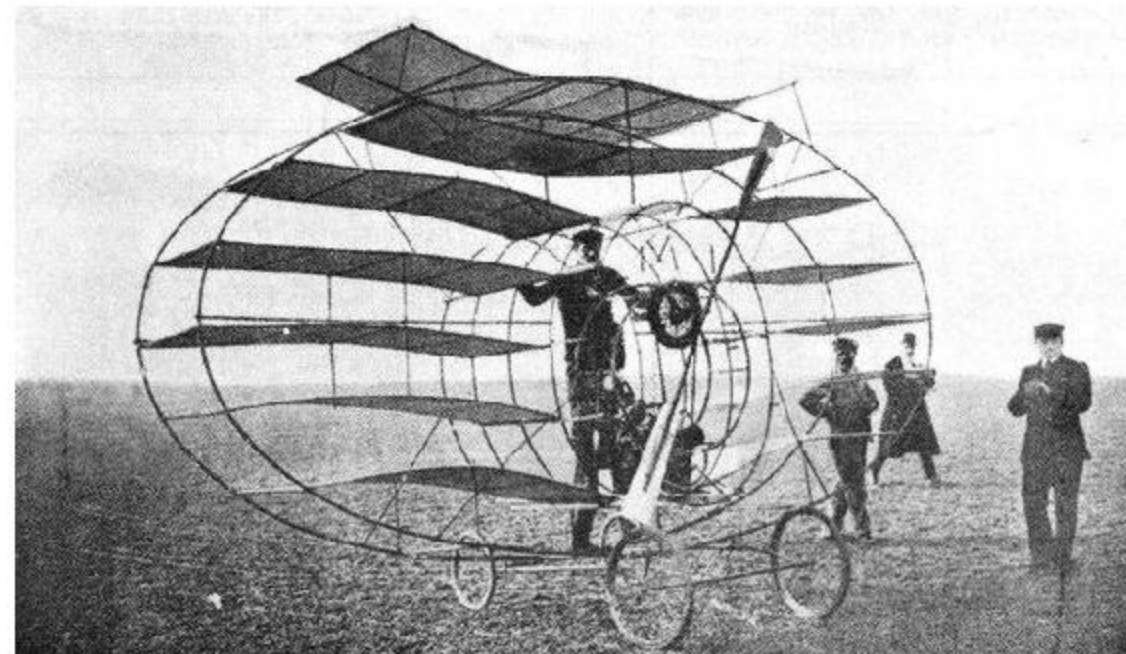

**D'EQUEVELLY** (1907-08). Interesting example of the strange machines devised by pioneers.

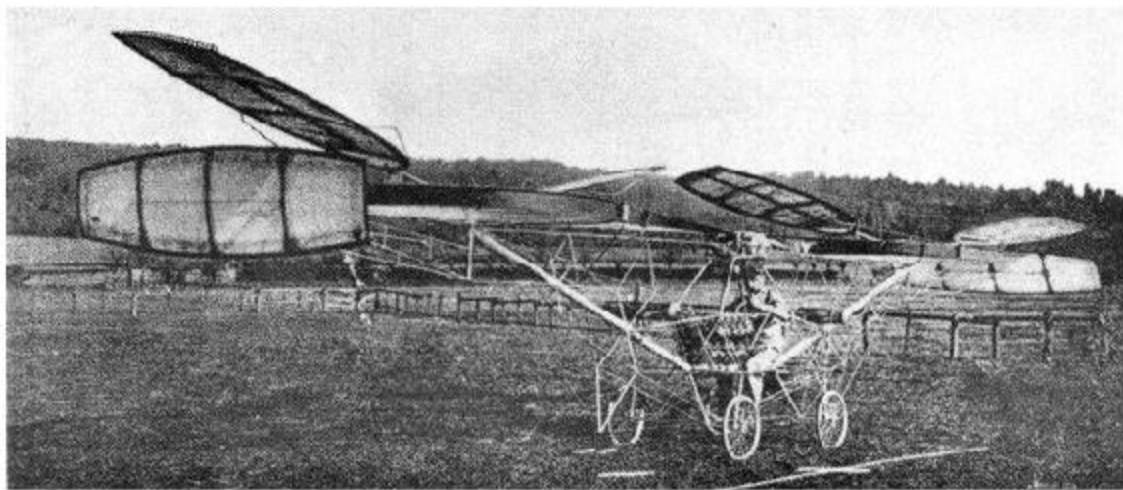

**CORNU** (1908). An early helicopter for which flights were claimed, but have also been denied.

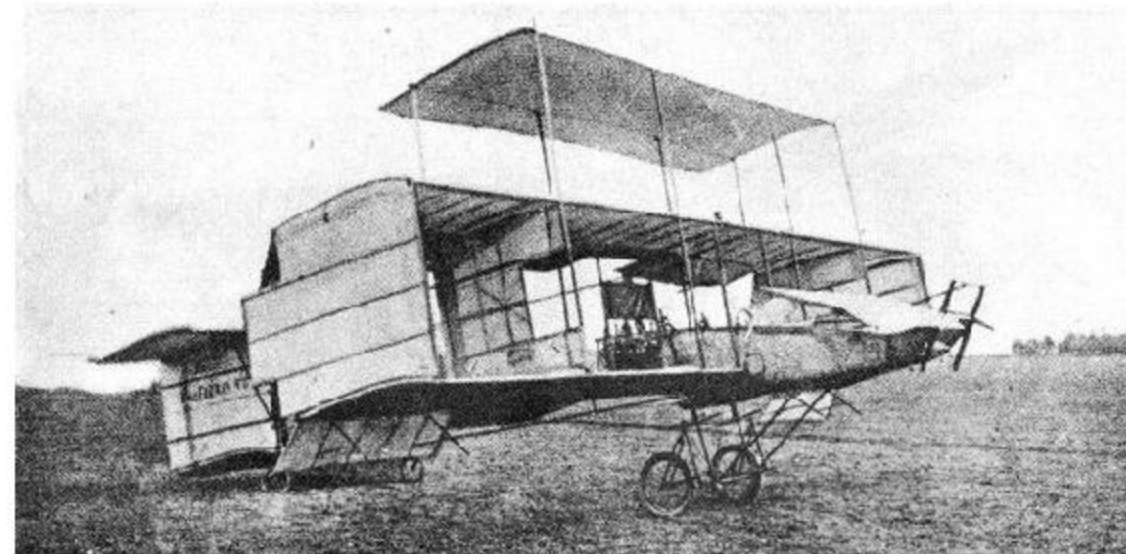

**H. FARMAN** (1907). This famous machine is the first *Voisin*, and the one on which H. Farman taught himself to fly. It was the first machine to make a turn in the air. Won the Deutsch-Archdeacon Grand Prix, 13th January, 1908, with a flight of 1 minute, 28 seconds. The extra third plane was added later. An Austrian Syndicate subsequently bought the machine.

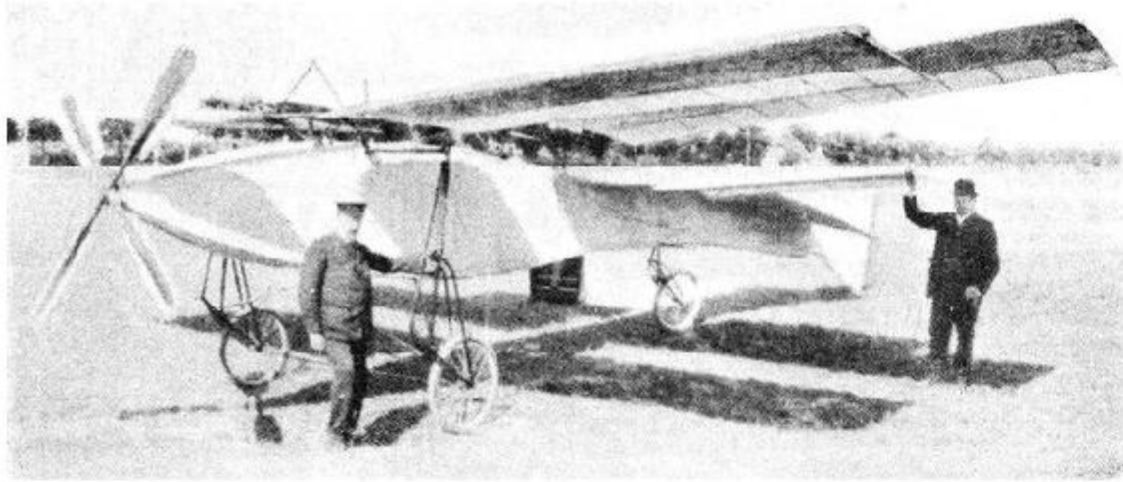

**H. FARMAN (1908).** Farman's first idea of a monoplane. It proved too heavy to fly with the power provided. Was eventually sold to a German officer. Three sets of wings and entirely enclosed body.

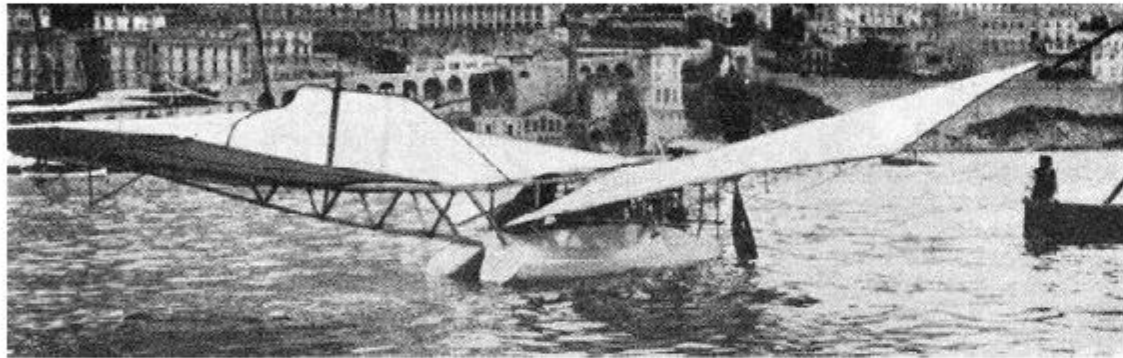

**GABARDINI (1909-10).** Very early hydro-aeroplane, antedating the *Fabre*.

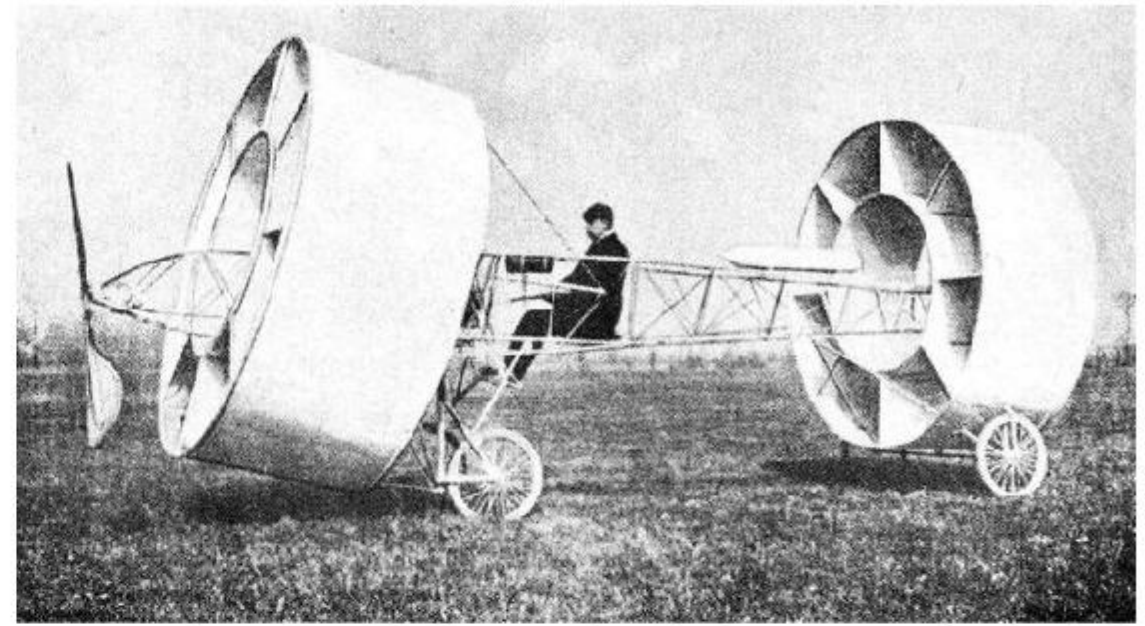

**GIVAUDIN (1908-09).** Built by the Vermorel Co. The first conception of an idea which has since attracted a certain class of inventor in Germany, Italy and the U.S.A.

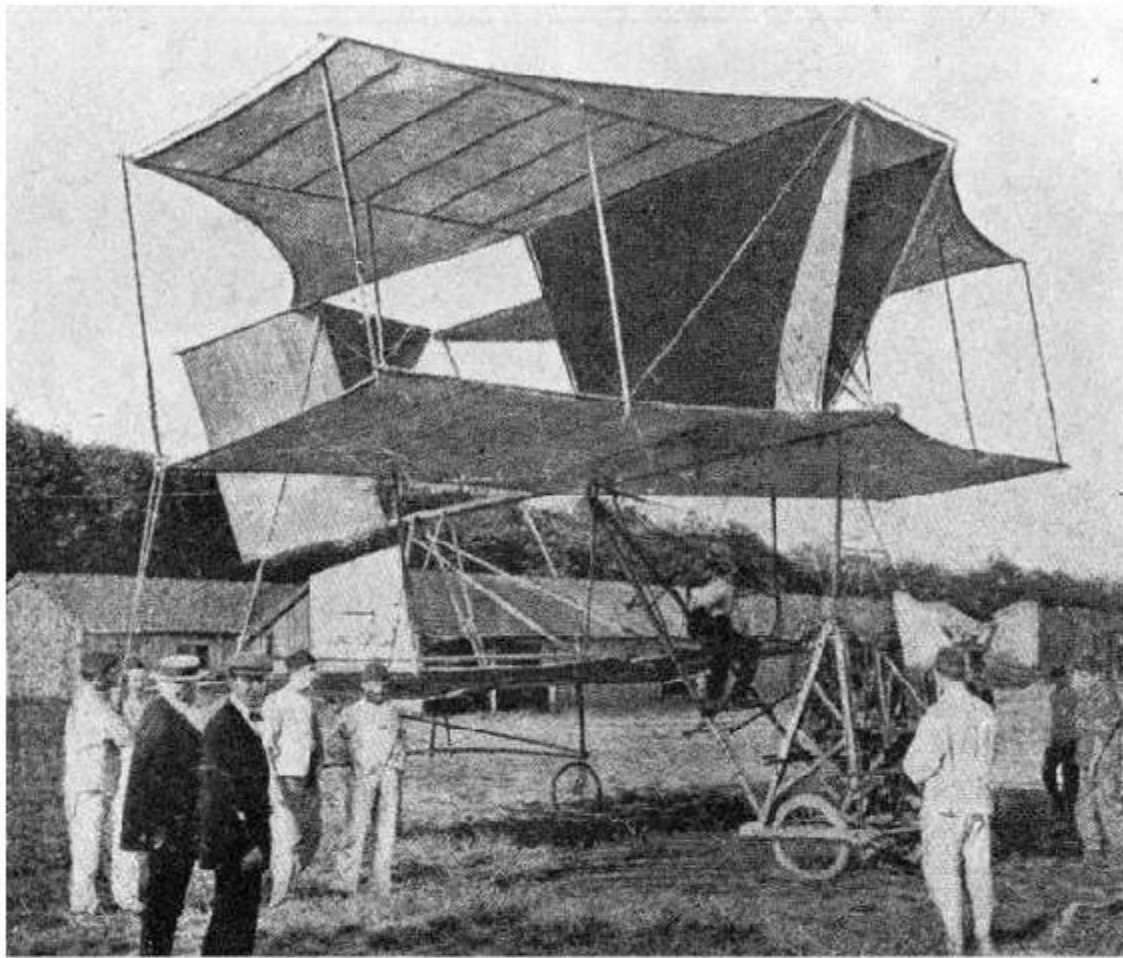

**MILITARY** (1909). The first special military aeroplane ever built. It was specially designed by Capt. Dorand, for what were then held to be the aerial necessities of the French Army. The planes were placed well above the body, giving the pilot a very clear uninterrupted view.

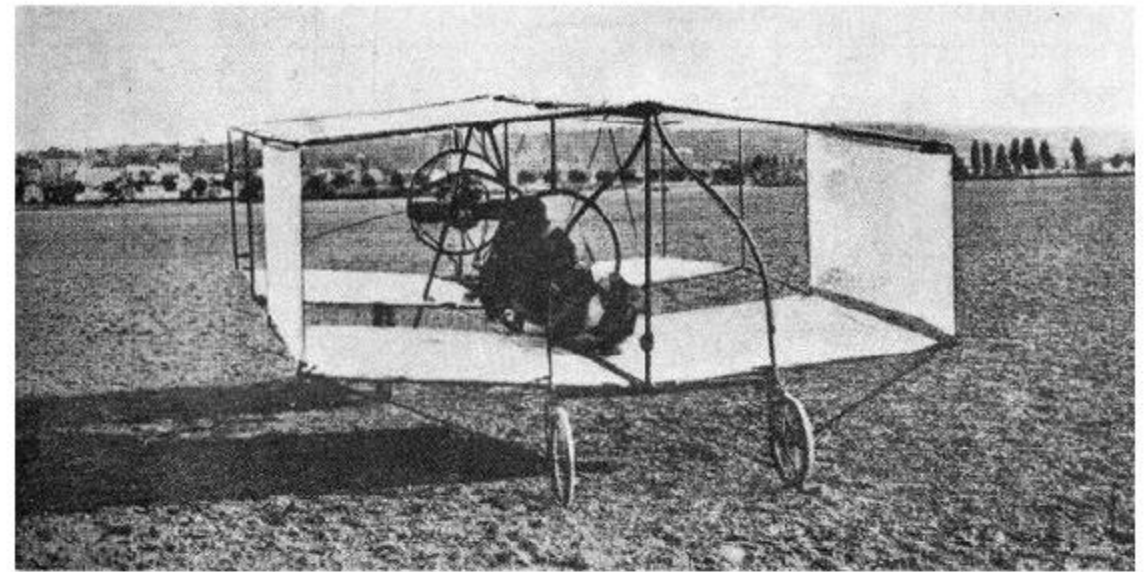

**PISCHOFF-KOECHLIN** (1906 or earlier). Dates from the days when a box-kite was the elementary idea in design, and the accepted position of the aviator lying prone.

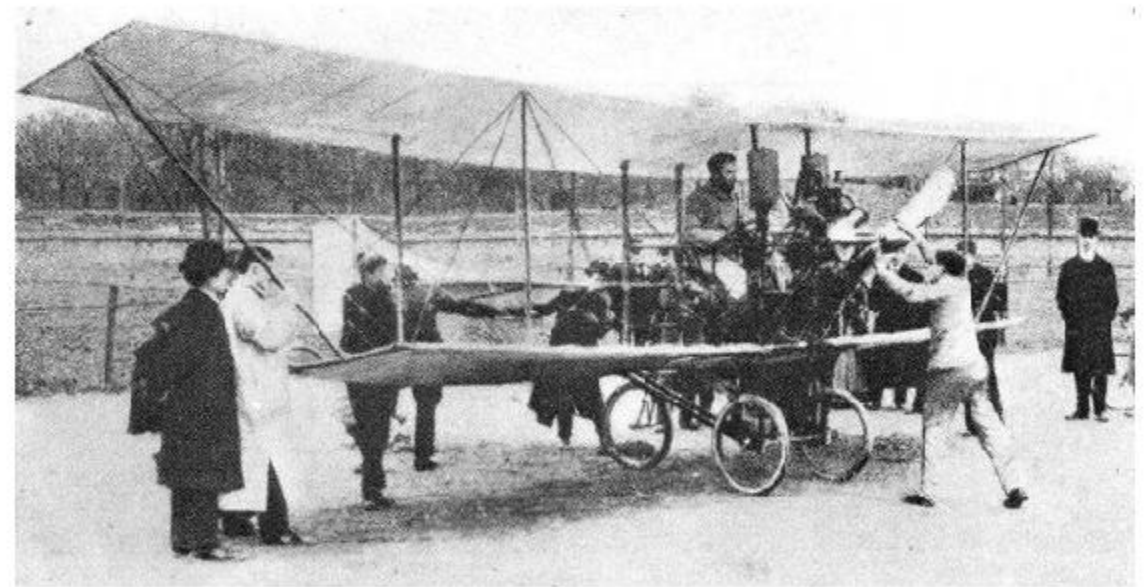

**PISCHOFF-KOECHLIN** (1908). Very early example of a tractor biplane. The extra span of the upper plane is also of interest. The machine had twin mono-elevators aft and also twin rudders.

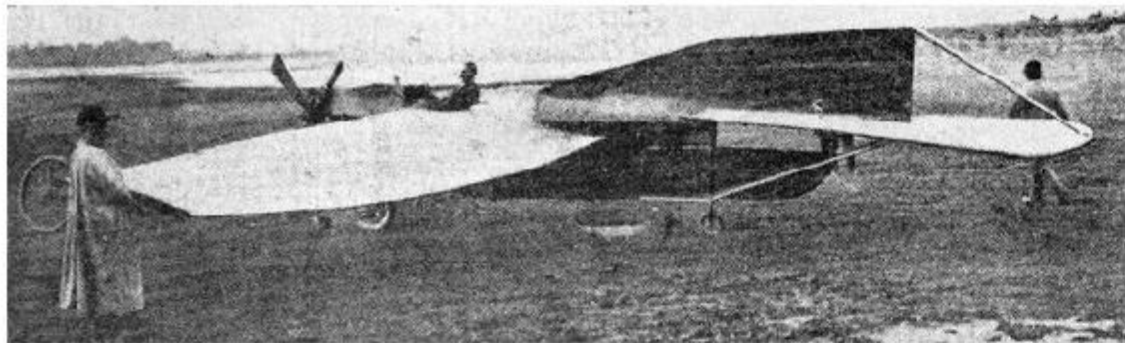

R.E.P. (1908). Early example of enclosed stream line body. Apparently the first machine in which steel construction appeared.



VOISIN (1908). The first European aeroplanes to fly with any real success.

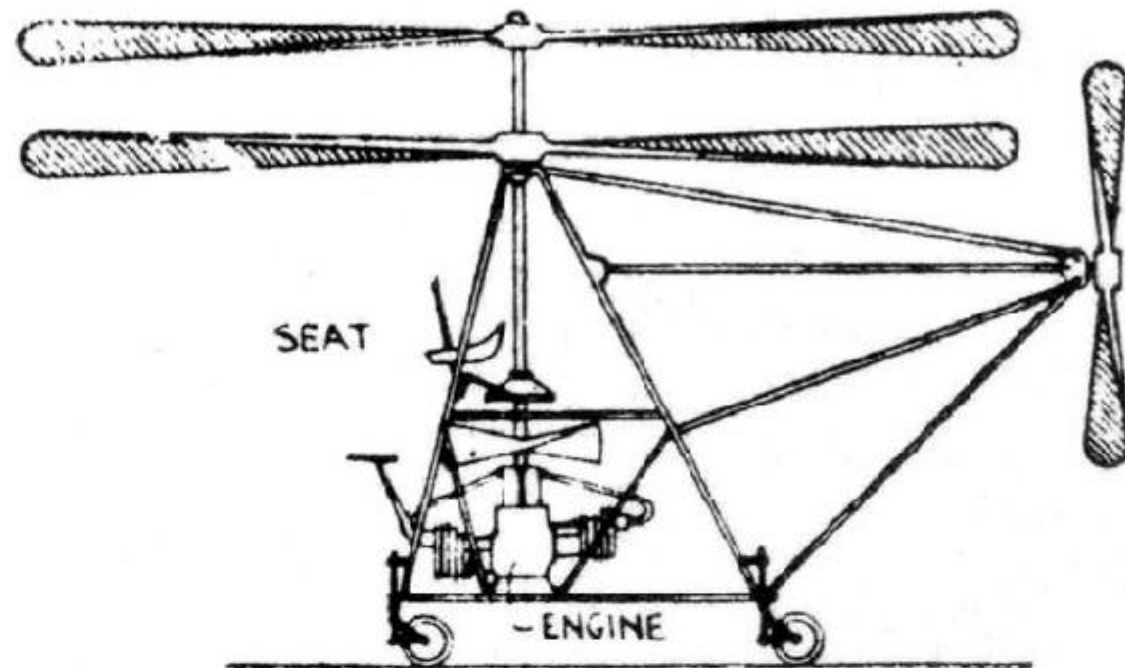

VUITTON-HUBER (1908). Early helicopter.

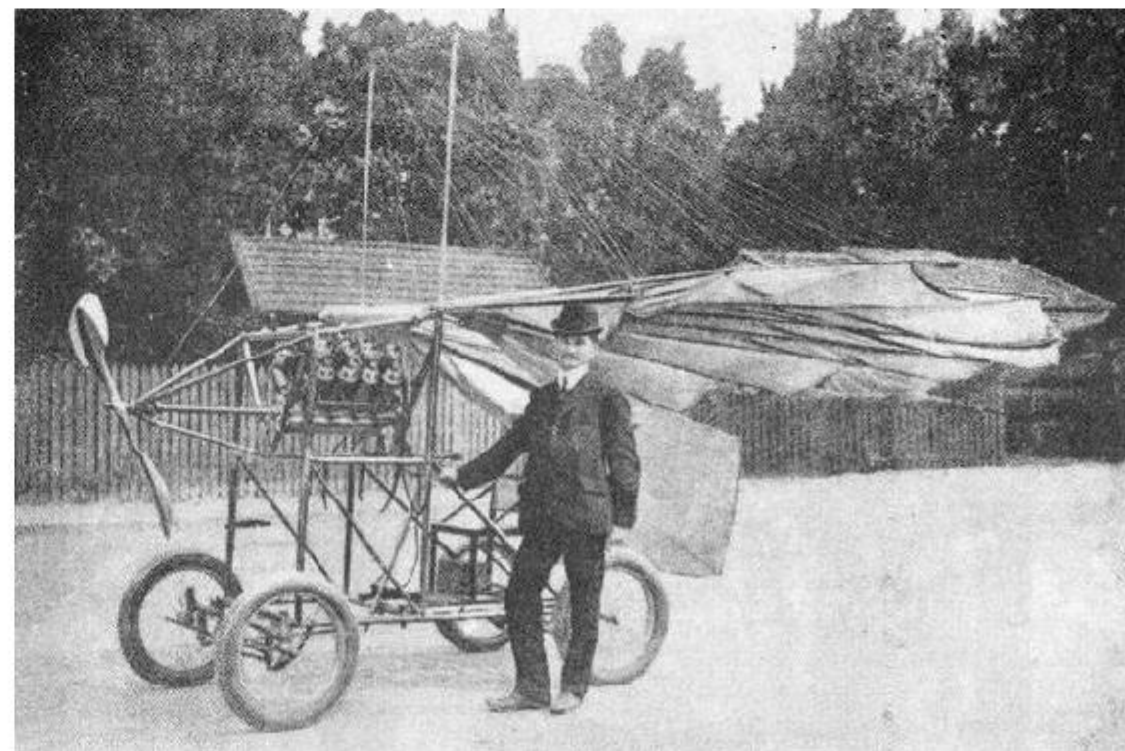

VUIA (1908). Earliest known machine with folding wings.

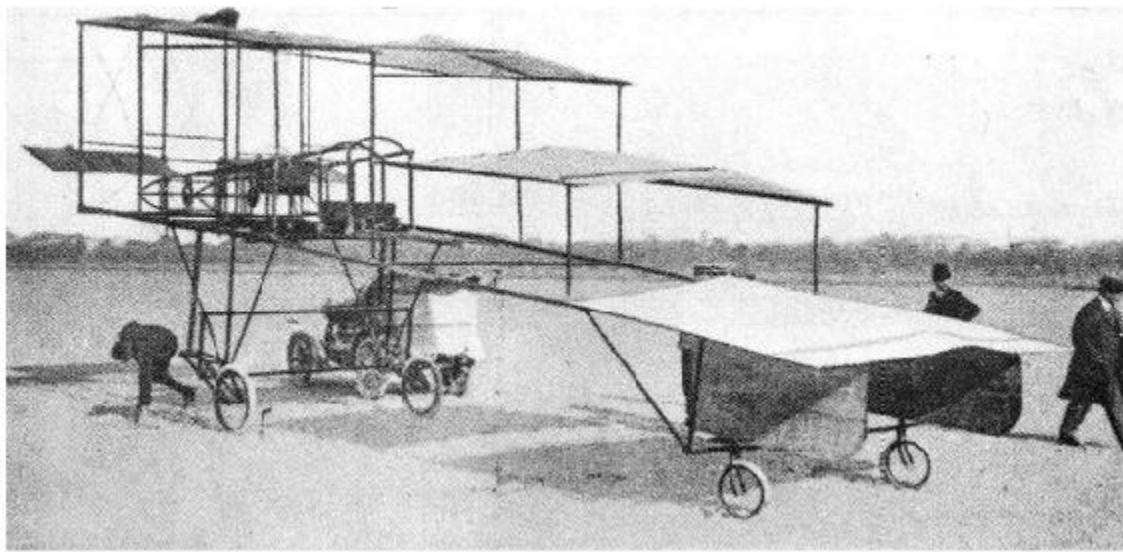

WITZIG-LIORE-DUTILLEUL (1908-09). First or one of the first appearances of the idea of a series of staggered planes, with which Sellers has ever since experimented in the U.S.A.

GERMAN.

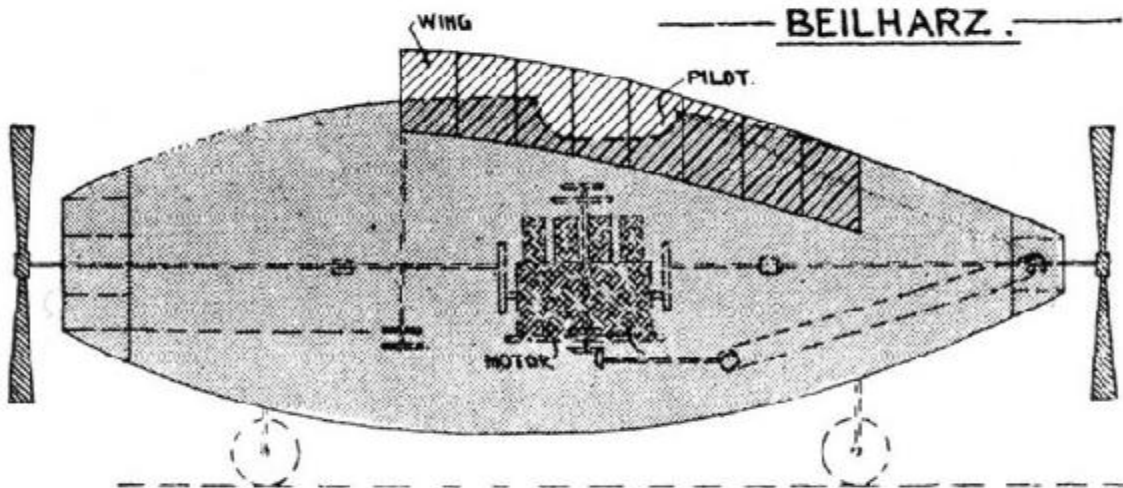

BEILHARZ. (1909). First design in which a completely closed in body figured.

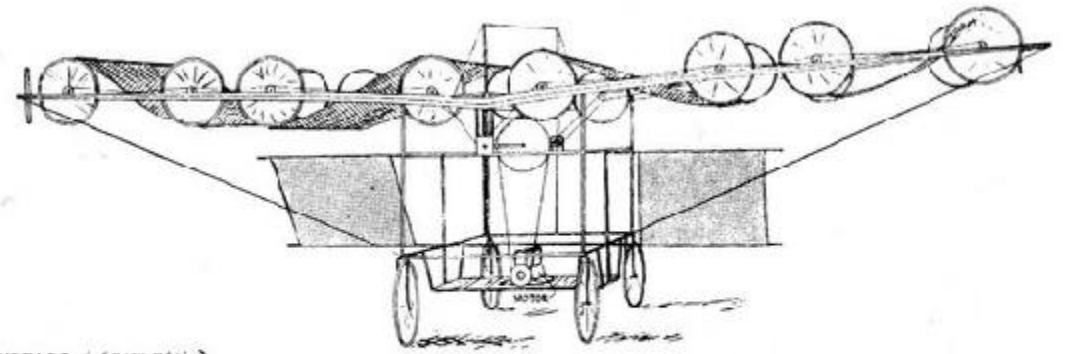

GEISLER (1908 photo)

GEISLER (1908).

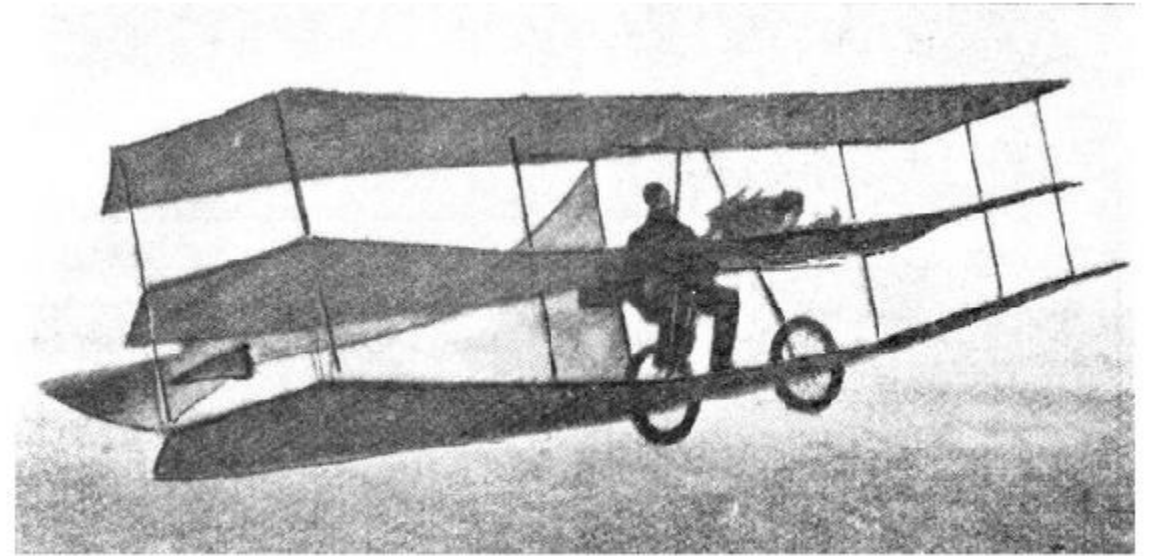

GRADE (1908). The first German built machine to fly.

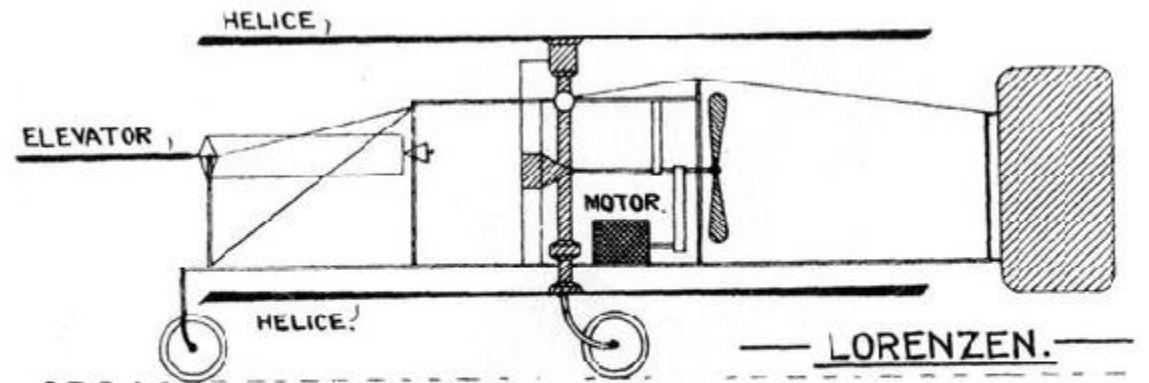

LORENZEN (1908-09).

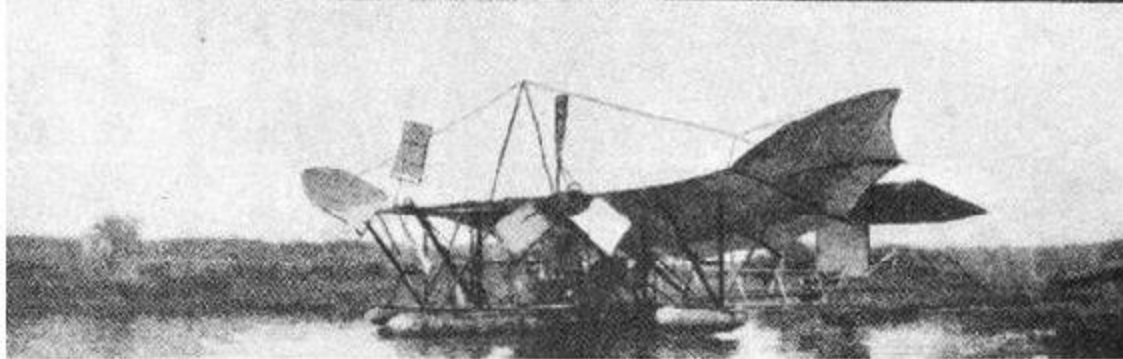
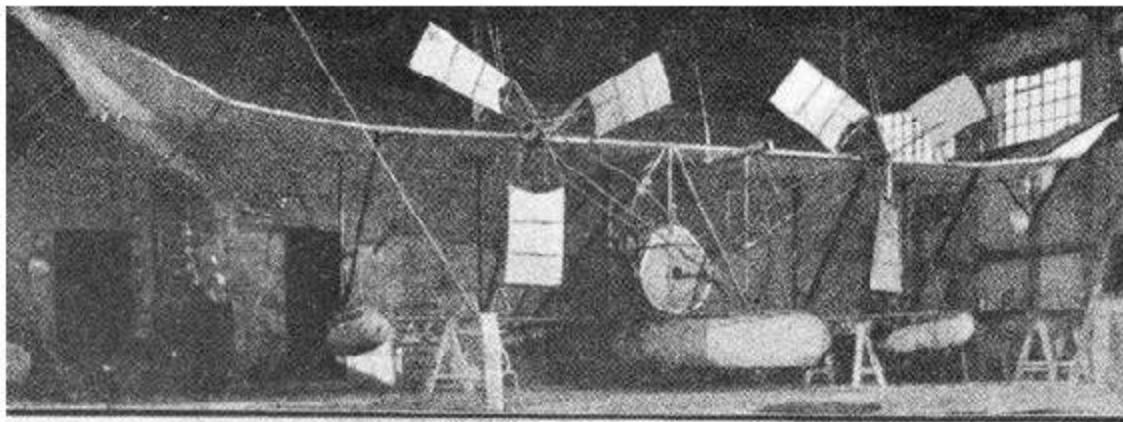

**PARSEVAL** (1909). Early hydro-aeroplane. Specially designed for military purposes by Major Parseval.

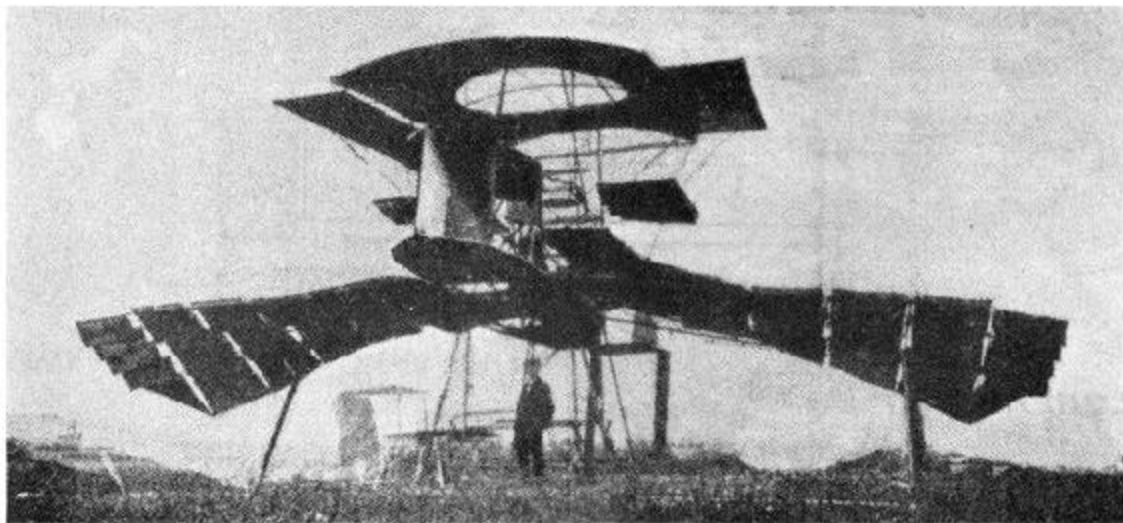

**SCHOLTZ** (1908). Never left the ground.

## ITALIAN.



**MILLER** (1908-09). First aeroplane to be designed and constructed by Italians.

## SWISS.

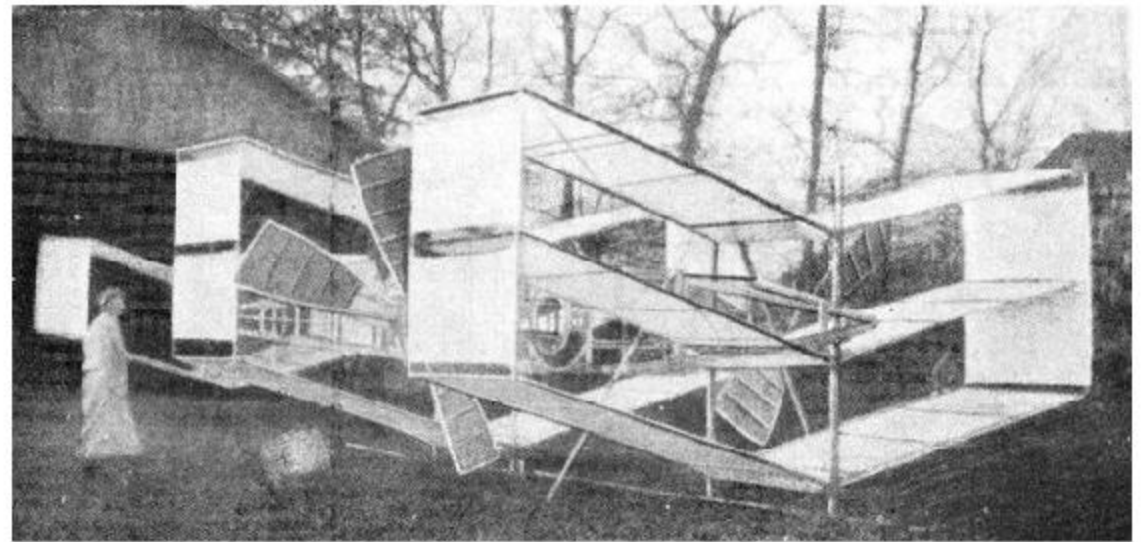

**DUFAUX** (1908-09). First Swiss machine.

U.S.A.

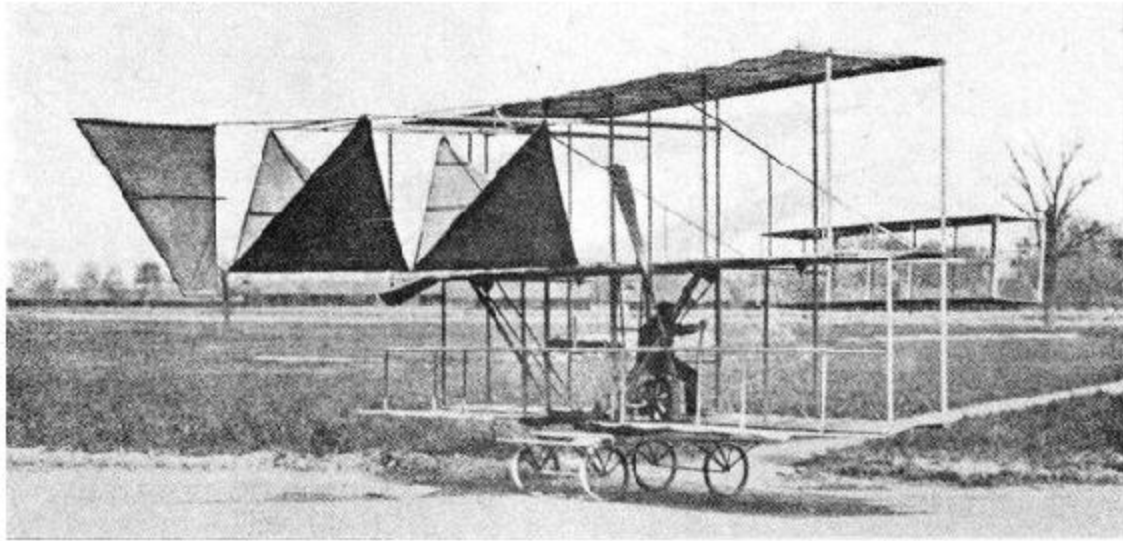

**BOKOR** (1909). The third American machine to leave the ground; the second purely U.S. one.

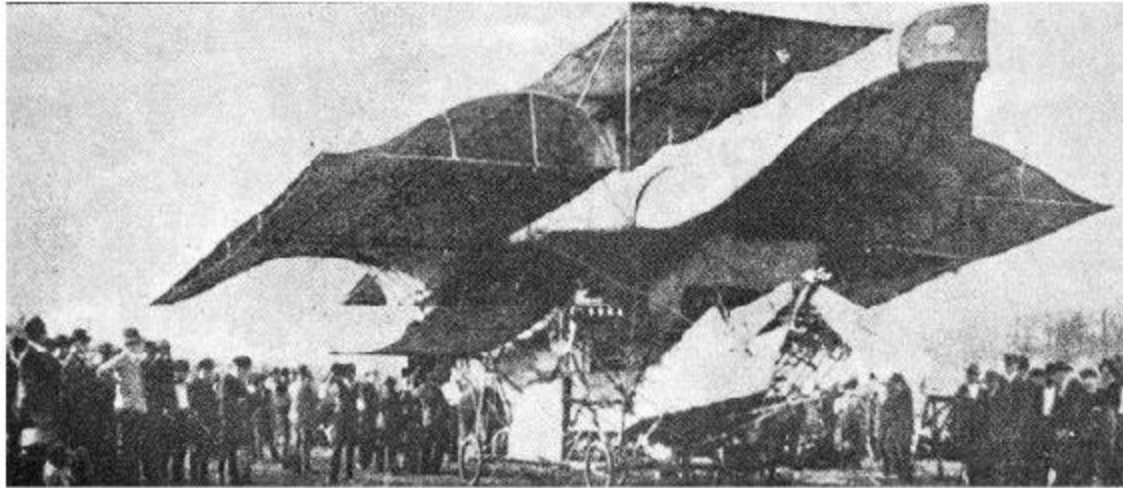

**CALL II** (1909).

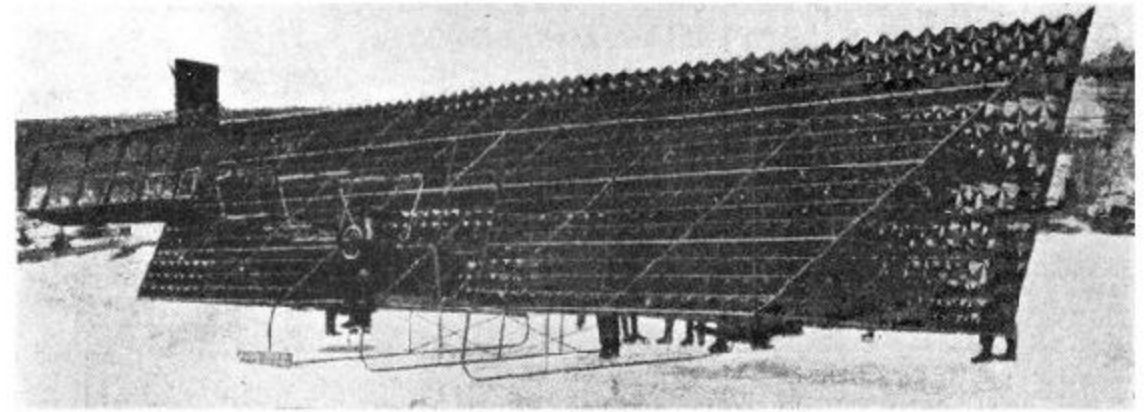

**CYGNET II** (1908). Designed by Dr. Graham Bell, of the Aeronautical Society of America. Bell (Canadian), Glen Curtiss (U.S.), Herring (U.S.), and Burgess (Canadian). It made short flights.

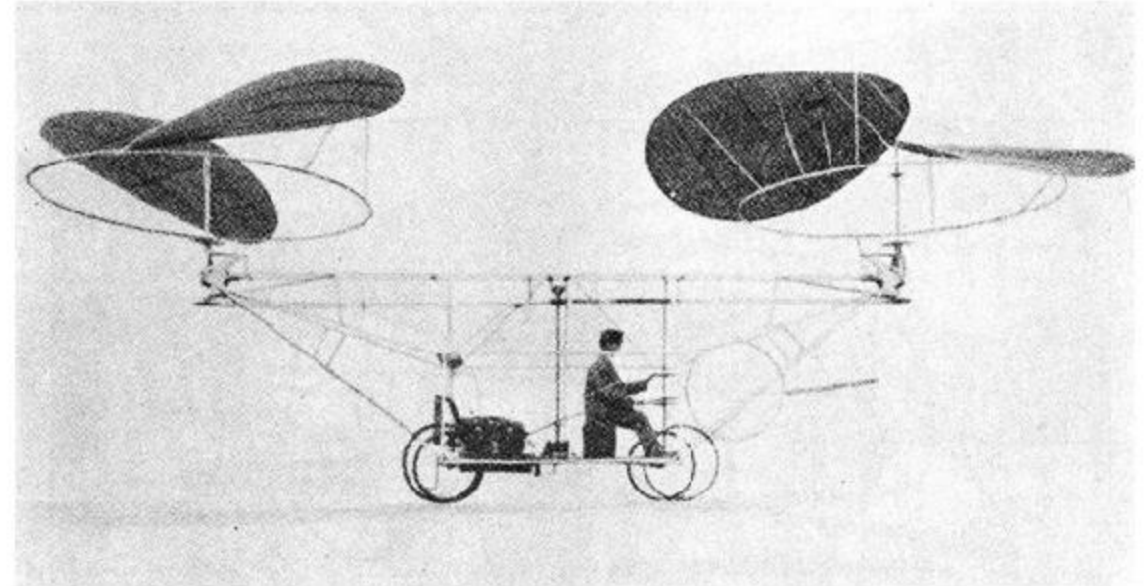

**ENGLISH** (1909). In 1909 extraordinary claims were made for this machine and great things expected. On a full power trial in its shed it broke loose, and smashed itself against the roof. No recorded outdoor results.

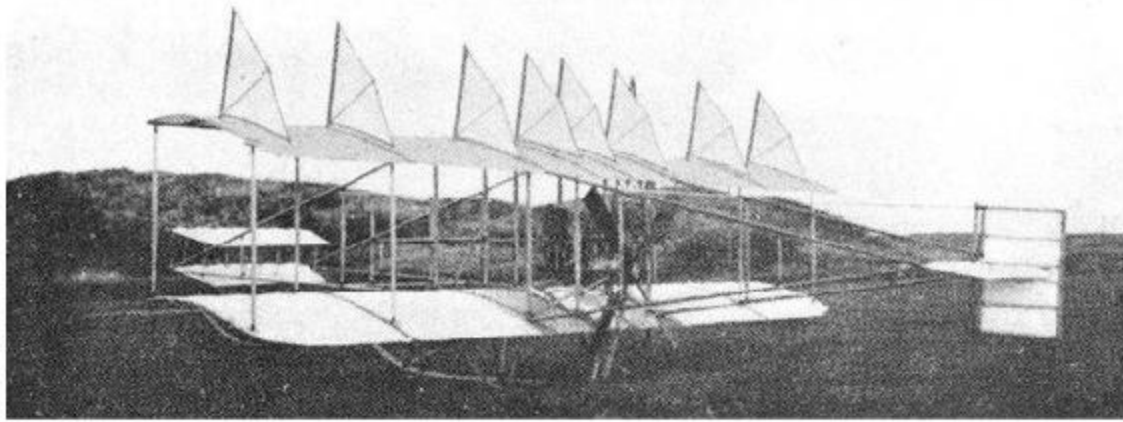

**HERRING-BURGESS (1910).**

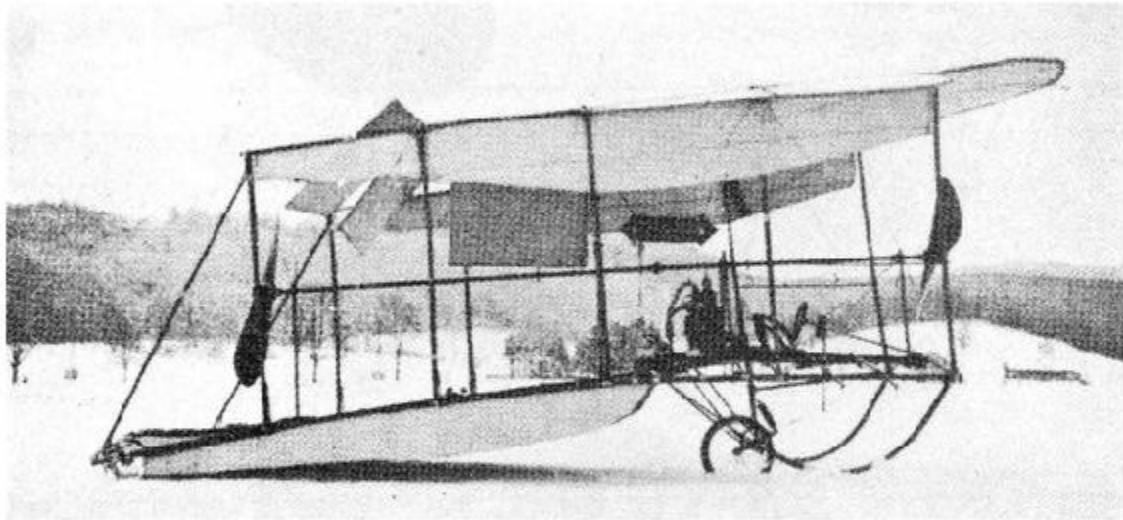

**HULBERT (1910).** This strange machine built in Switzerland by Dr. Dane Hulbert, achieved several flights. The planes were placed longitudinally instead of in the usual way.

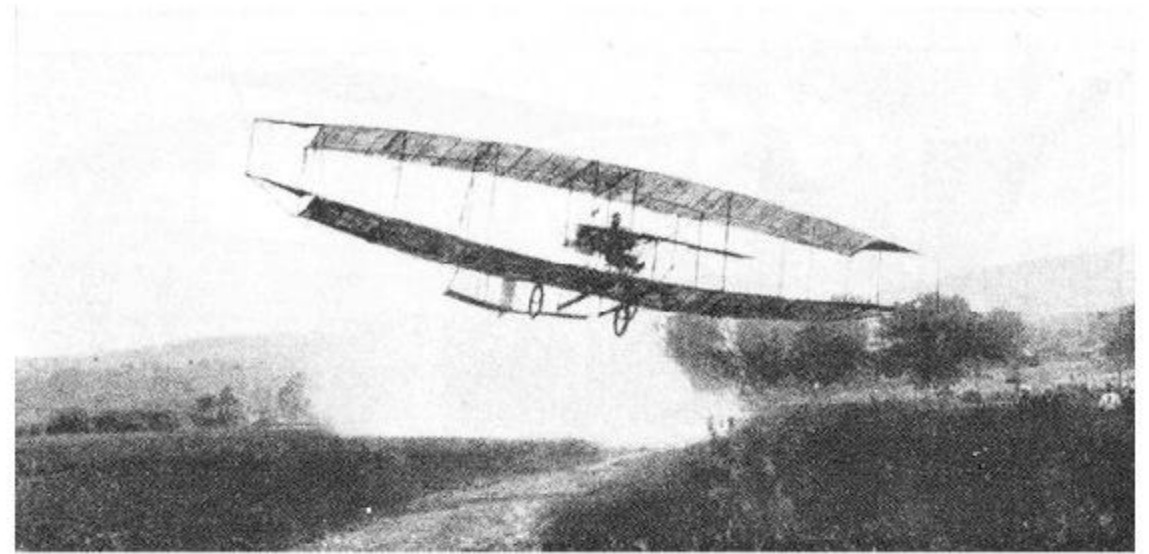

**JUNE BUG (1908-09).** Famous machine of its era. Built by the Aeronautical Society of America (see *Cygnets II*). Second machine to fly in the U.S.A. Did 2000 miles before being broken up.

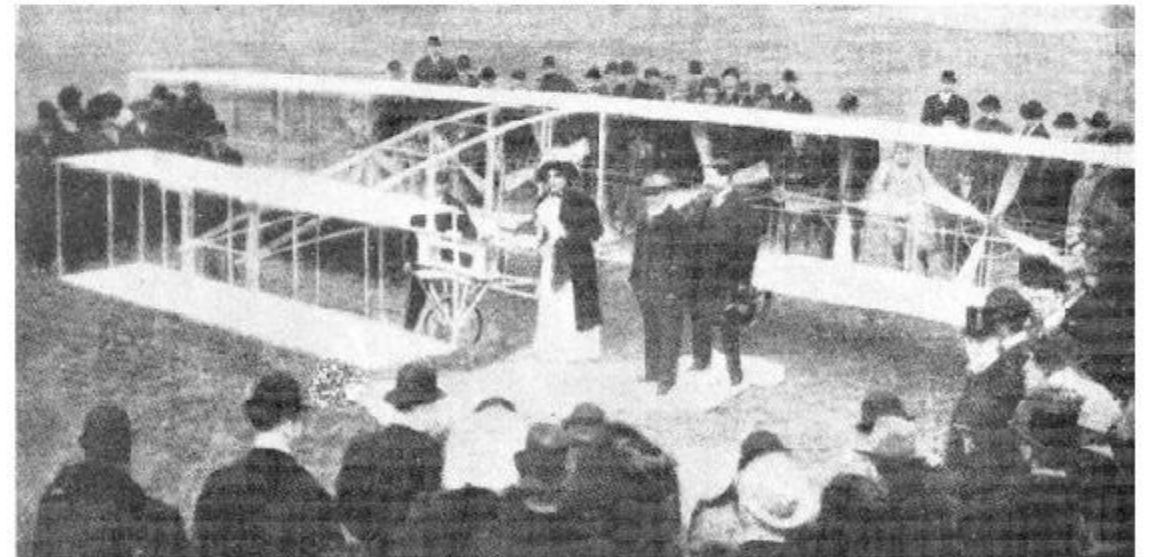

**KIMBALL (1909).** First machine in which a large number of propellers was attempted. Failed.



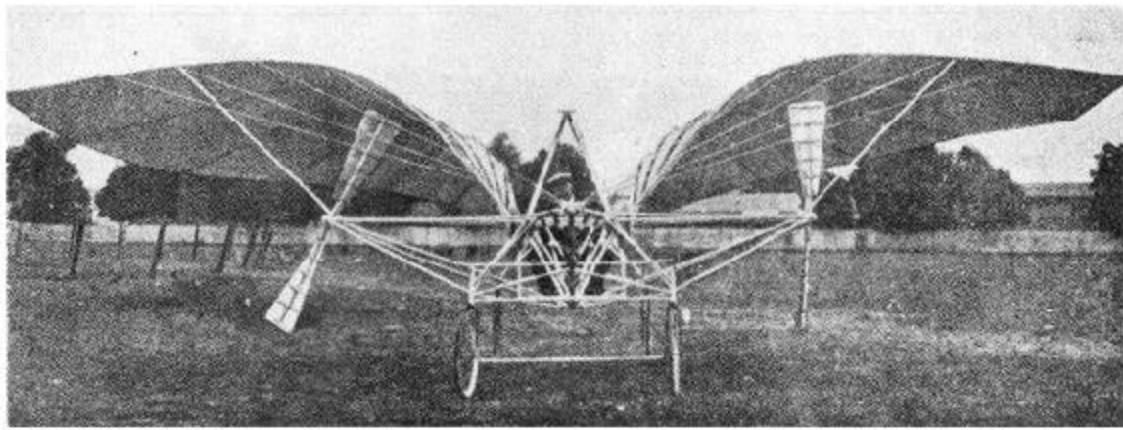

**LOOSE (1910).**

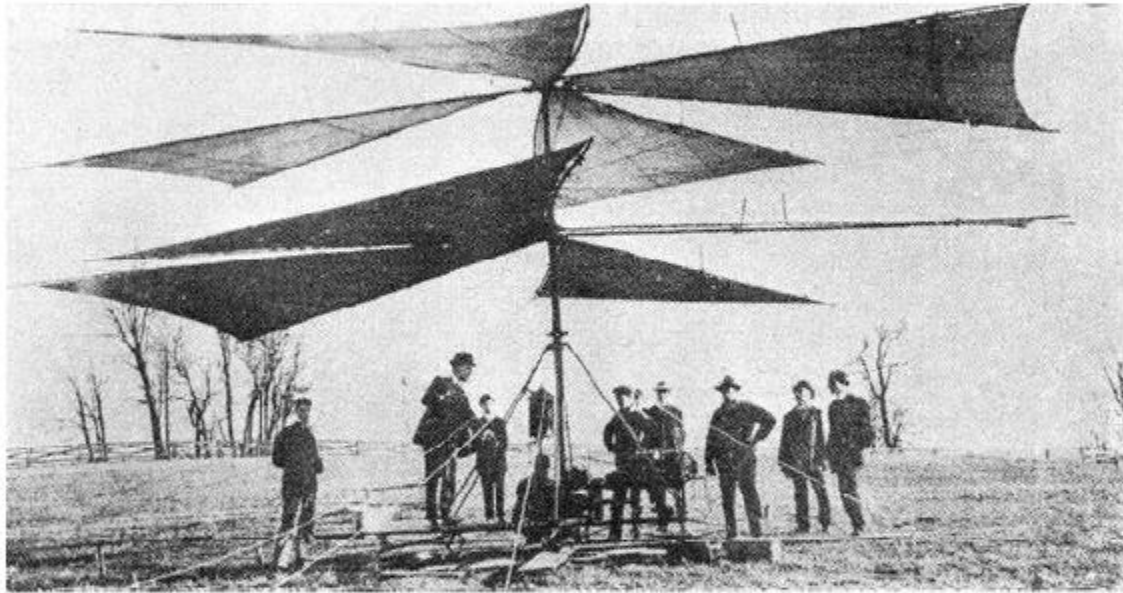

**LUYTIES OTTO (1908).**

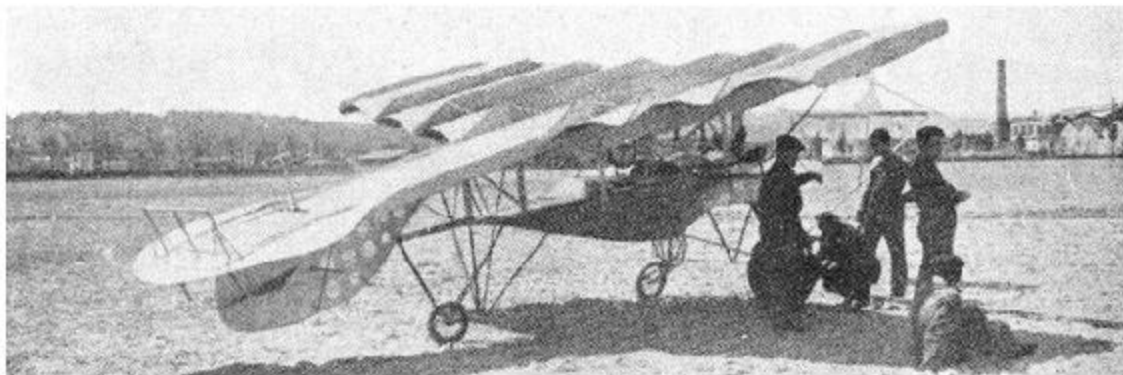

**MOISSANT (1910).** Built entirely of aluminium. Designed by the late John Moissant. Failed.

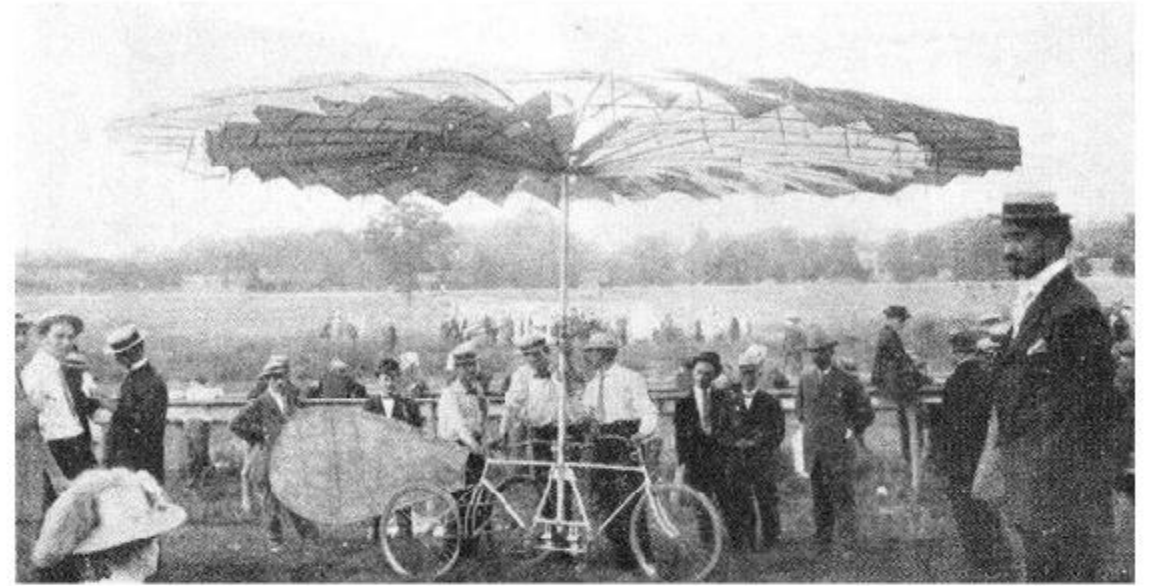

**RICKMAN (1908).**

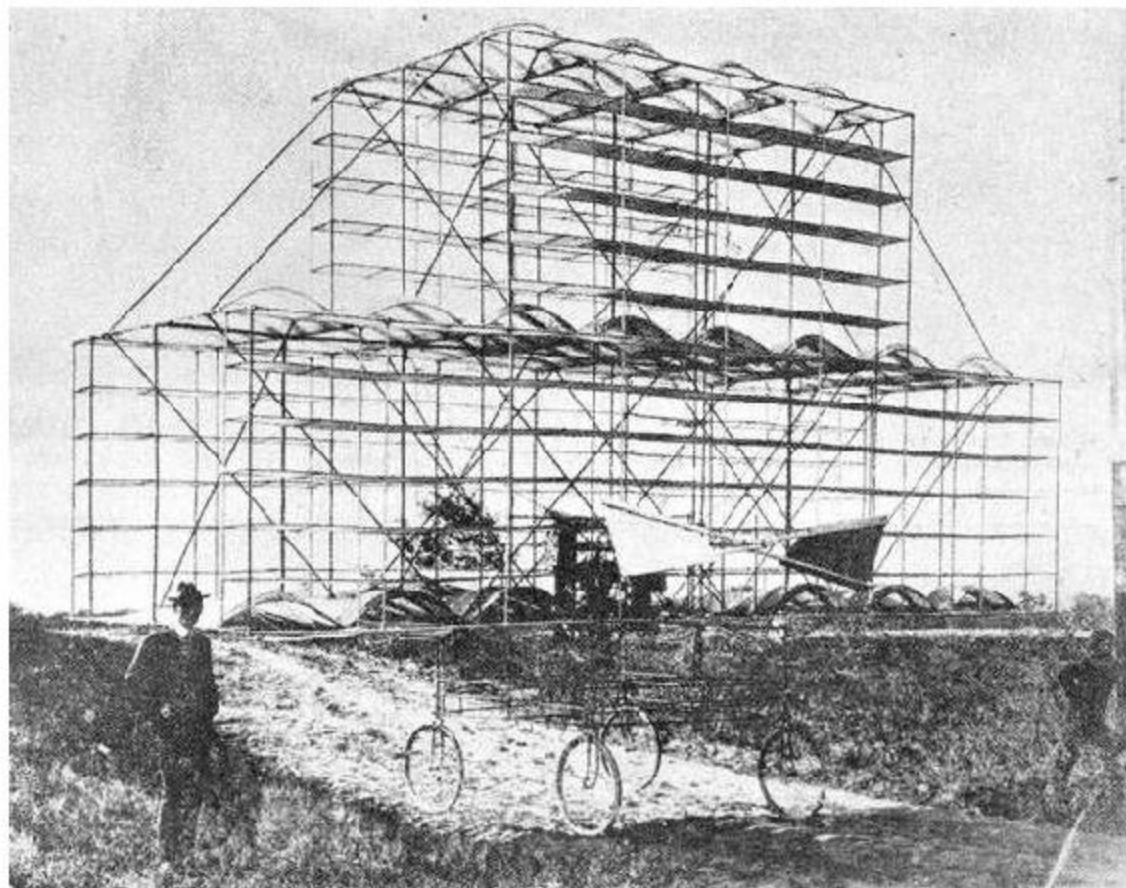

**ROSHON (1908).**

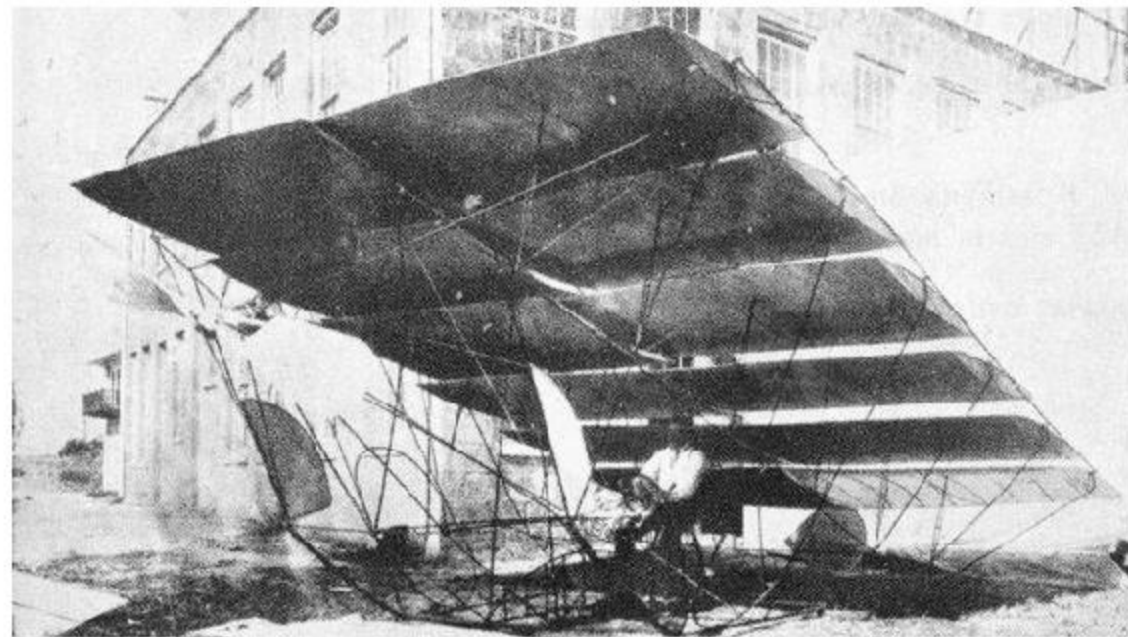

**ZERBE (1909).**

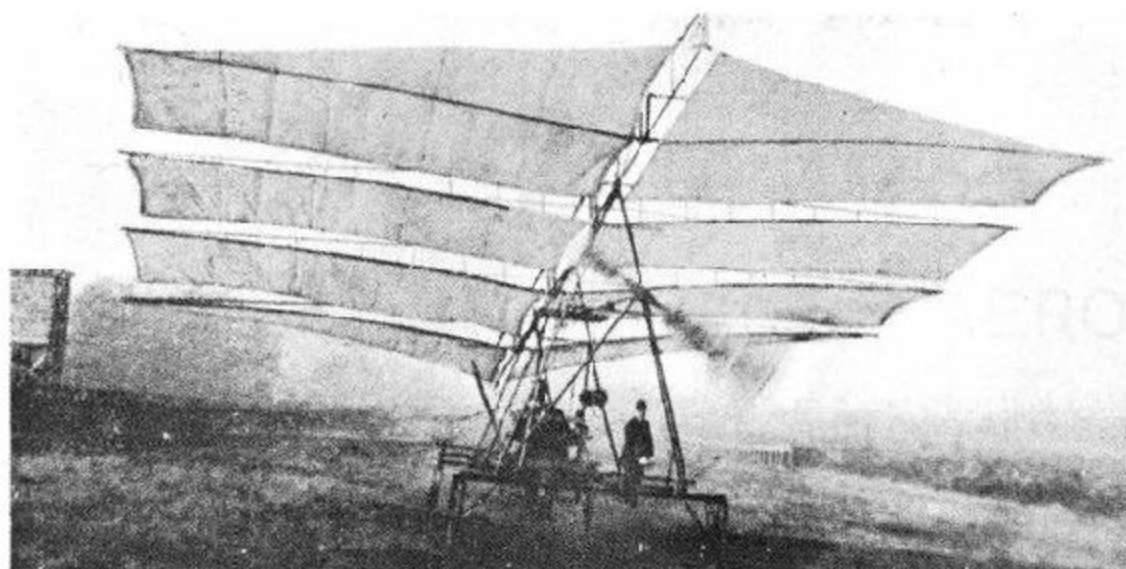

**WILLIAMS (1908).**

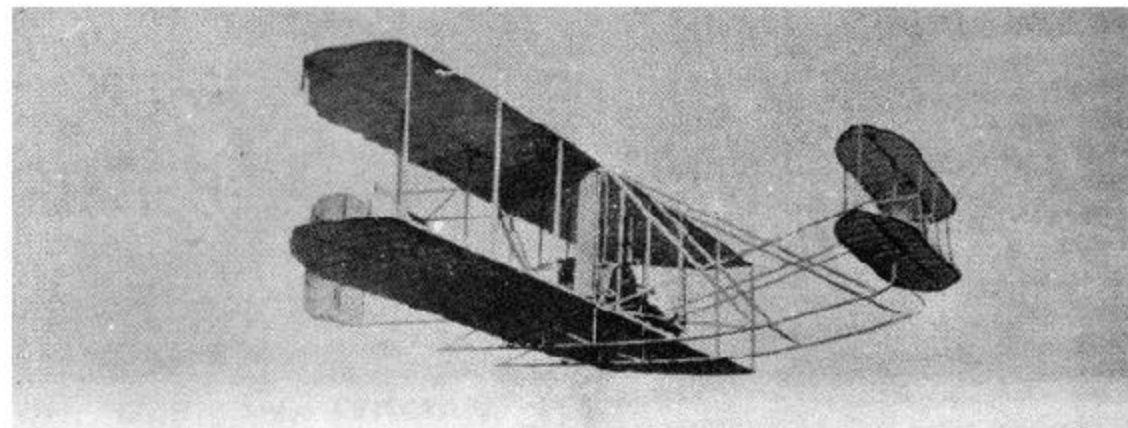

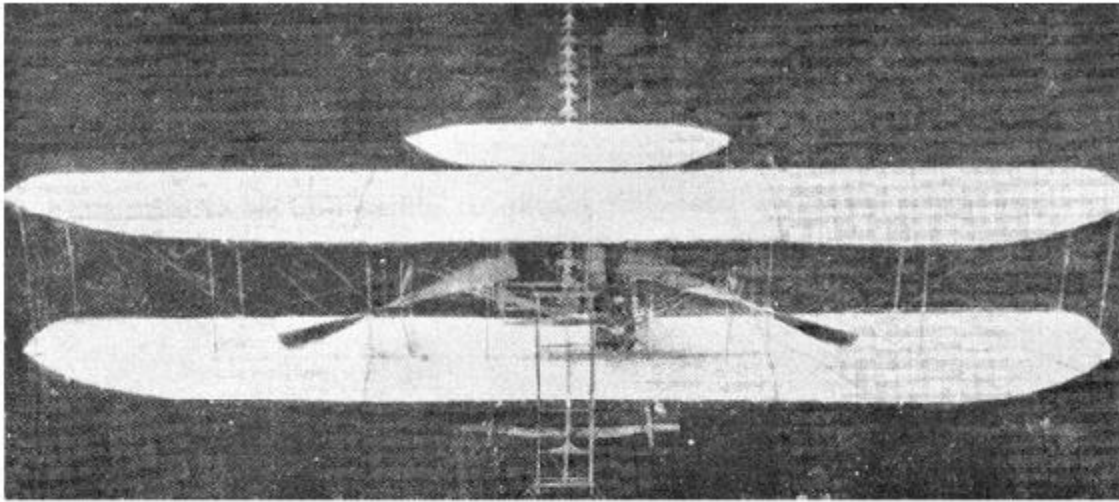

**WRIGHT** (1908). Two views of the machine with which Wilbur Wright startled all Europe from August, 1908 to April, 1909. First U.S. machine to fly.

## AERO ENGINES,

ALPHABETICALLY ARRANGED IN ORDER OF COUNTRY OF ORIGIN.

[AUSTRIAN](#), [BELGIAN](#), [BRITISH](#), [FRENCH](#), [GERMAN](#), [ITALIAN](#), [U.S.A.](#)

**Note.**—So far as possible this is a complete list of all the aero engines of any importance.

Data are confined to what is now being made or actually in use; untested "show novelties" are ignored.

In the case of some engines it has for various reasons proved impossible to obtain full data in time for inclusion in this edition.

In a general way these lists are confined to aeroplane engines.

# AUSTRIAN.

Revised by Herr Ing. W. Isendahl.

---

AUSTRO-DAIMLER.

---

35-40 h.p., 4 cyl., 100×120 (1450 r.p.m.) 165 lbs.  
 65-70 h.p., 4 cyl., 120×140 (1350 r.p.m.) 232 lbs.  
 120 h.p., 6 cyl., 130×175 (1200 r.p.m.) 419 lbs.

Vertical water-cooled.

H.T. Magneto.  
 All Valves overhead. Rocking levers and piston rods.  
 Forced lubrication.

Pressed steel pistons.  
 Nickel-chrome crank shaft, hollow and closed.  
 White-metal bearings.  
 Cast-iron single cylinders (copper jackets).  
 Single camshaft.

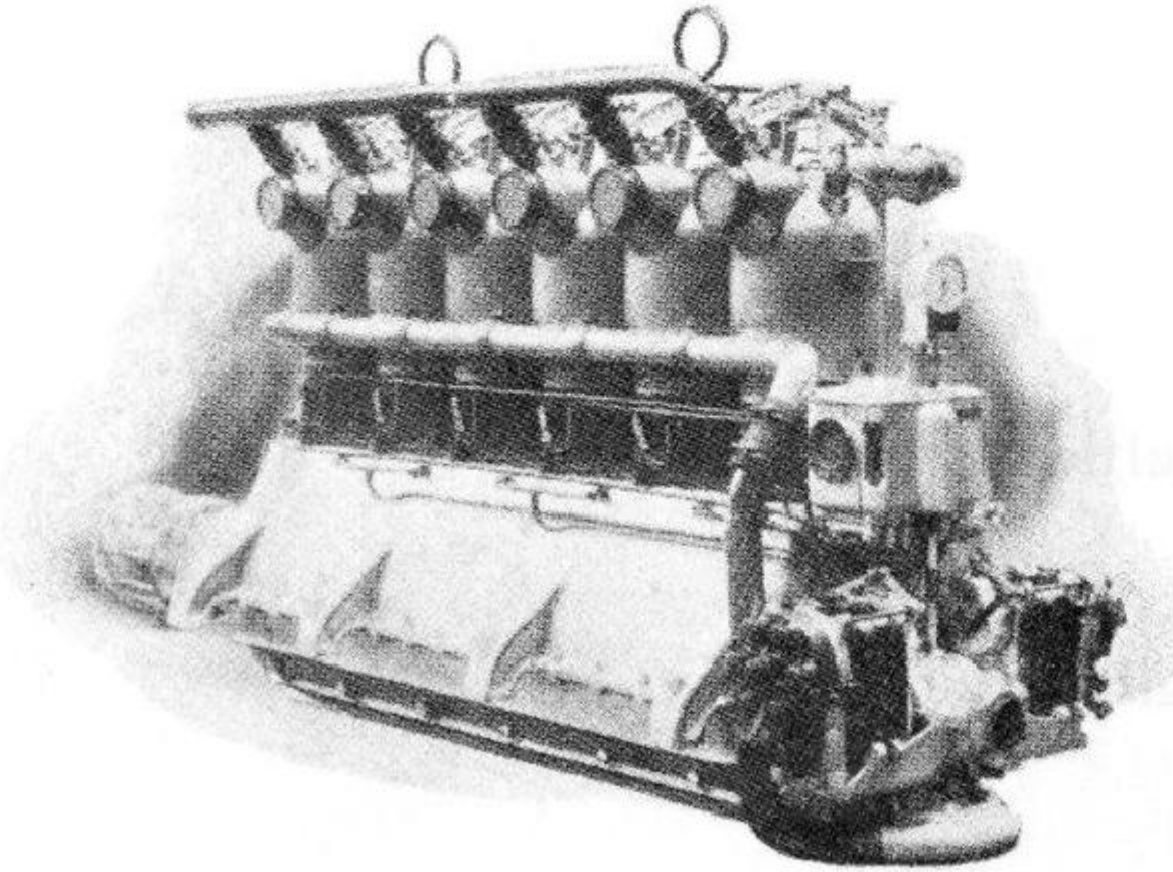

120 h.p.

The 120 has 2 carburetters and 2 H.T. magnetos.

<b>BELGIAN.</b>	
METALLURGIQUE	PIPE.
40 h.p., 4 cyl., 85×130 (1850 r.p.m.) 60 h.p., 4 cyl., 100×150 (1850 r.p.m.) 300 lbs. 90 h.p., 4 cyl., 125×150 (1600 r.p.m.) 550 lbs.	50-70 h.p., 8 cyl., 100×100 (1950 r.p.m.) 239 lbs. 110 h.p., 8 cyl.
Vertical, water-cooled. H.T. magneto. Mechanical inlets. Pump lubrication.	Vertical, air-cooled (fan). H.T. magneto. Mechanical inlets. Pump lubrication.
MIESSE.	VIVINUS.
50-60 h.p., 4 cyl. lbs. 100 h.p., 8 cyl., 130×140 245 lbs.	50 h.p., 4 cyl., 106×120 (1600 r.p.m.) 205 lbs. 60 h.p., 4 cyl., 112×130 (1600 r.p.m.) 236 lbs. 70 h.p., 4 cyl., 115×130 (1800 r.p.m.) 280 lbs.
Horizontal opposed, air-cooled (fan). H.T. magneto Mechanical inlets. Pump lubrication.	Vertical, water-cooled. H.T. magneto. Mechanical inlets. Pump lubrication.
<i>Features.--</i>	
Air cooling is carried out by fans which drive air through air jackets on cylinders.	
All valves in cylinder heads, rocker operated.	
Vertical crank shaft.	
KORTING.	4450

Note.--This engine is no longer made, but it is to be found still in some dirigibles.

## BRITISH.

### A.B.C.

All British Engine Co., Ltd., Brooklands, Surrey.

30 h.p., 4 cyl., 95×80 (1450 r.p.m.) 155 lbs.

45 h.p., 6 cyl., 95×80 (1450 r.p.m.) 225 lbs.

60 h.p., 8 cyl., 95×80 (1450 r.p.m.) 231 lbs.

85 h.p., 6 cyl., 125×105 (1700 r.p.m.) 290 lbs.

115 h.p., 8 cyl., 125×105 (1400 r.p.m.) 380 lbs.

170 h.p., 12 cyl., 125×105 (1400 r.p.m.) 520 lbs.

225 h.p., 16 cyl., 125×105 (1400 r.p.m.) 640 lbs.

### GREEN.

Green Engine Co., Ltd., 455, Berners Street, London, W.

V type, water-cooled (pump).

H.T. magneto.

Mechanical inlets.

Forced lubrication.

*Features.--*

Steel cylinders (steel and copper jackets).

Overhead vertical valves.

Cast-steel crank case.

Nickel chrome crank shaft, white metal bearings.

N.E.C.

New Engine (Motor) Co. Ltd., 9, Grafton Street, Bond Street, London, W.

50 h.p., 4 cyl., 95×115 (1250 r.p.m.) 205 lbs.

WOLSELEY.

90 h.p., 6 cyl., 96×115 (1500 r.p.m.) 405 lbs. Motor Car Co., Ltd., Adderley Park, Birmingham.

Two stroke vertical for the 90 h.p. V for the 50.

H.T. magneto.

Valveless.

Forced lubrication.

*Features.--*

Pistons after uncovering exhaust ports open the inlet ports. Air from blowers scavenges. Strong mixture enters immediately on compression stroke. This is effected by a central mechanism.

(N.B. Older types see previous editions.)

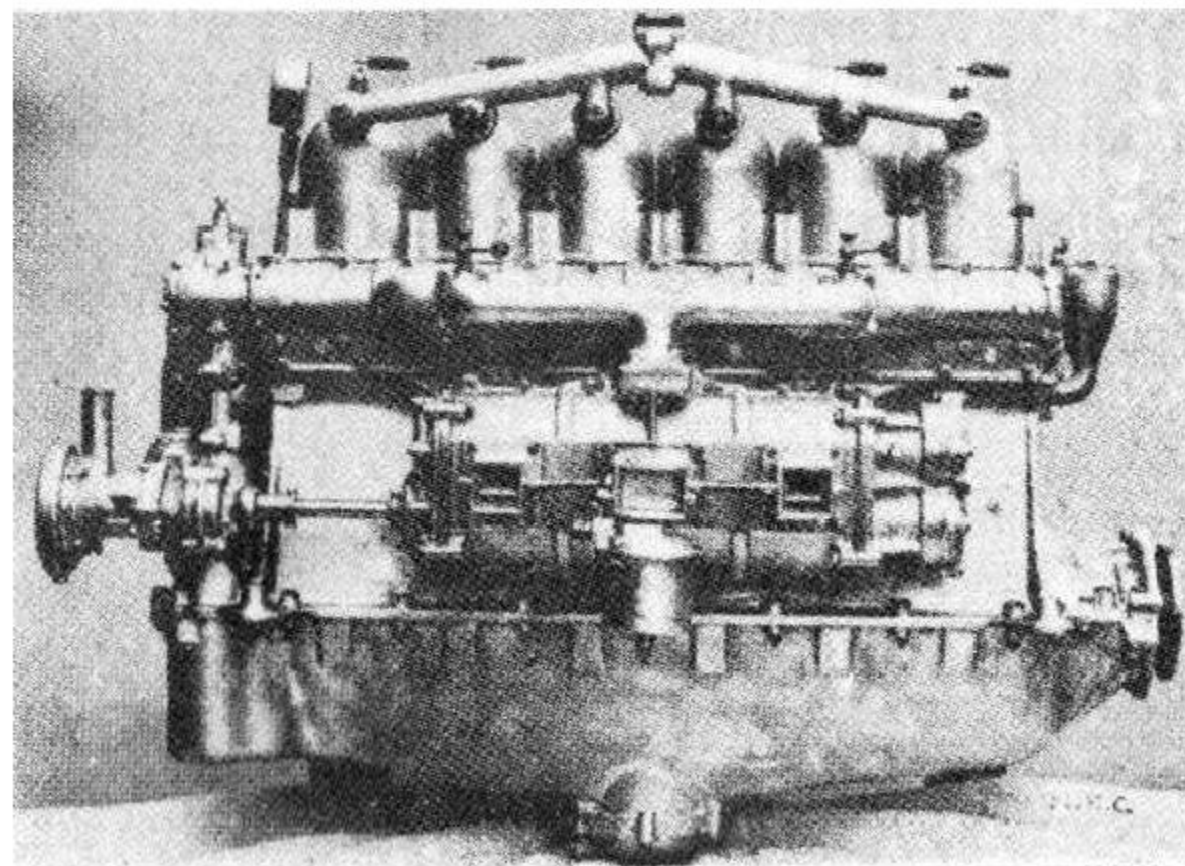

## FRENCH.

### ANZANI.

71, bis Quai d'Asinières (Seine).

30 h.p., 3 cyl., 105×130 (1575 r.p.m.) 154 lbs.  
30 h.p., 3 cyl., 105×120 (1300 r.p.m.) 121 lbs.  
40-45 h.p., 6 cyl., 90×120 (1300 r.p.m.) 154 lbs.  
50-60 h.p., 6 cyl., 105×120 (1300 r.p.m.) 200 lbs.  
80 h.p., 10 cyl., 90×130 (1250 r.p.m.) 238 lbs.  
100 h.p., 10 cyl., 105×140 (1100 r.p.m.) 308 lbs.

Radial type, air-cooled (but water-cooling is occasionally fitted).

H.T. magneto.  
Mechanical inlets.  
Forced lubrication.

#### Features.--

Extremely simple construction.  
Mainshaft single crank.  
Flywheel specially balanced to compensate.  
Zenith carburetter.

### CANTON-UNNÉ (SALMSON).

E. Salmson, 55, rue Grange aux Belles, Paris.

60 h.p., 7 cyl., 75×260 (1300 r.p.m.) 220 lbs.  
80 h.p., 7 cyl., 120×140 (1250 r.p.m.) 298 lbs.  
110 h.p., 9 cyl., 120×140 (1300 r.p.m.) 353 lbs.

The 60 h.p. has parallel a.c. cylinders, the other two are radial w.c.  
**BERTIN.**  
8, rue Garancier, Paris.

There is also a horizontal radial engine (w.c.) 300 h.p., 9 cyl., 150×210 (1200 r.p.m.) 990 lbs.

50 h.p., 4 cyl., 116×150 (1100 r.p.m.) 132 lbs.  
H.T. magneto.  
Mechanical inlets.

100 h.p., 8 cyl., 116×150 (1100 r.p.m.) 209 lbs.  
Forced lubrication.  
Air cooled.  
Steel cylinders, copper jackets.  
Overhead Valves.  
Single special steel crank shaft on ball bearings.  
Aluminium alloy or steel crank case.

### BURLAT.

289 Avenue de Saxe, Lyon (Rhône).

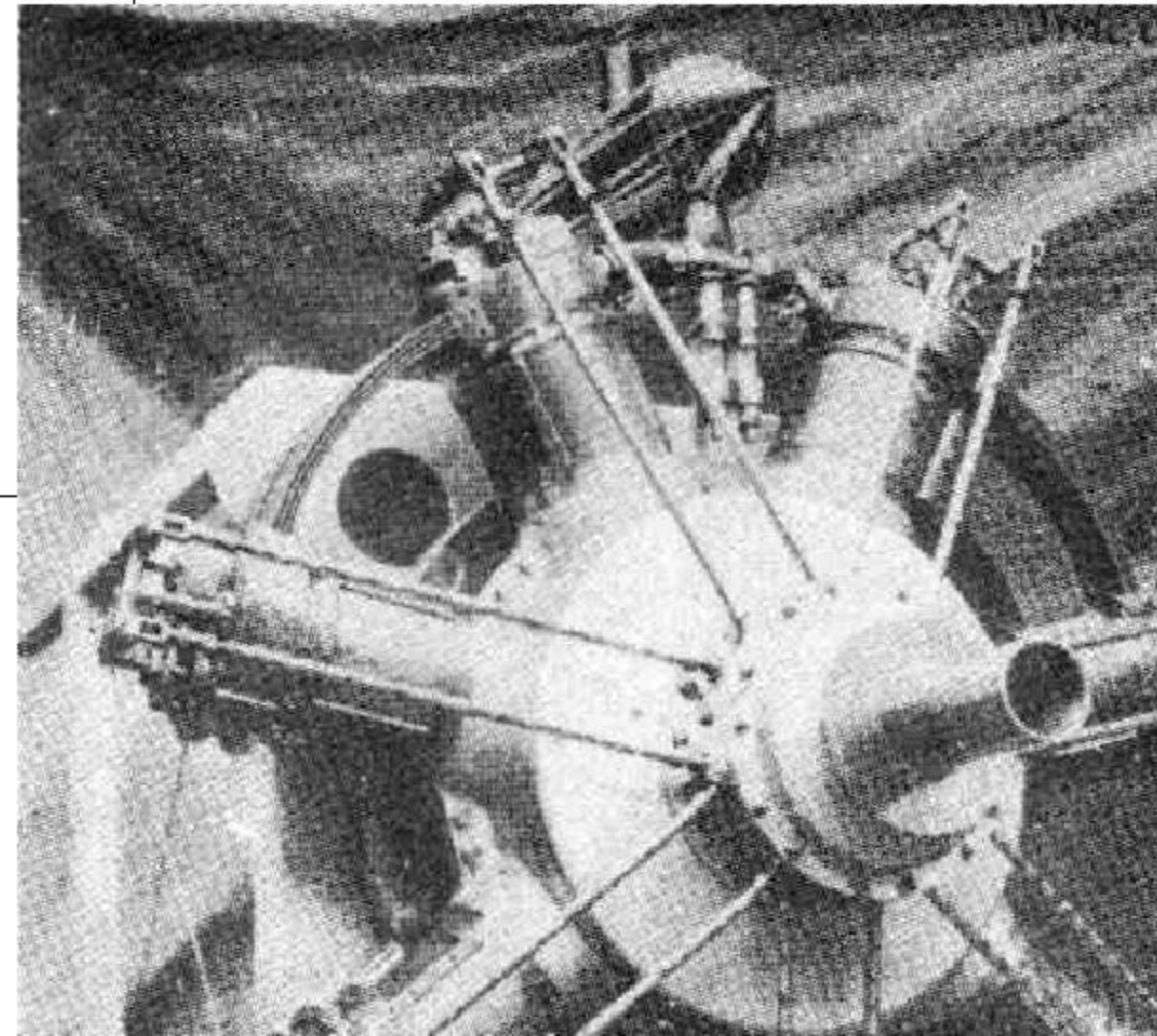



### CHENU.

Chenu, 10 Rue Fontaine-Saint-Georges, Paris.

50 h.p., 4 cyl., 110×130 (1300 r.p.m.) 253-1/2 lbs.

75 h.p., 6 cyl., 110×130 (1300 r.p.m.) 375 lbs.

200 h.p., 6 cyl., 150×200 860 lbs.

Vertical, water-cooled (thermo syphon).

H.T. magneto.

Automatic lubrication.

Cylinders in pairs.

### DANSETTE GILLET (LAVIATOR).

Dansette Gillet & Cie., 36 quai de Suresnes, Suresnes (Seine).

80 h.p., 8 cyl., 100×130 (1200 r.p.m.) 418 lbs.

110 h.p., 6 cyl., 130×160 (1100 r.p.m.) 616 lbs.

120 h.p., 4 cyl., 145×175 (1200 r.p.m.) 484 lbs.

120 h.p., 8 cyl., 114×160 (1200 r.p.m.) 418 lbs.

200 h.p., 8 cyl., 147×175 (1100 r.p.m.) 715 lbs.

250 h.p., 6 cyl., 180×200 (1050 r.p.m.) 1210 lbs.

The 110, 120 (4 cyl.) and 250 are vertical, the others are V type.

### DE DIORGET.

Établissements de De Dion-Bouton & Cie., 52 Avenue des Champs-Élysées, Paris.

80 h.p., 8 cyl., 110×130 (1700 r.p.m.) (480 lbs.)

150 h.p., 8 cyl., 125×150 (1600 r.p.m.) 172 lbs.

V type, air-cooled for the 80; water-cooled for the 150.

50-60 h.p., 7 cyl., 120×120 (1200 r.p.m.) 198 lbs.

H.T. magneto.

Pump lubrication.

Forced lubrication. 43 h.p. 50 and 100 vertical engines, w.c.

The 50-60 h.p. is a radial, rotary.

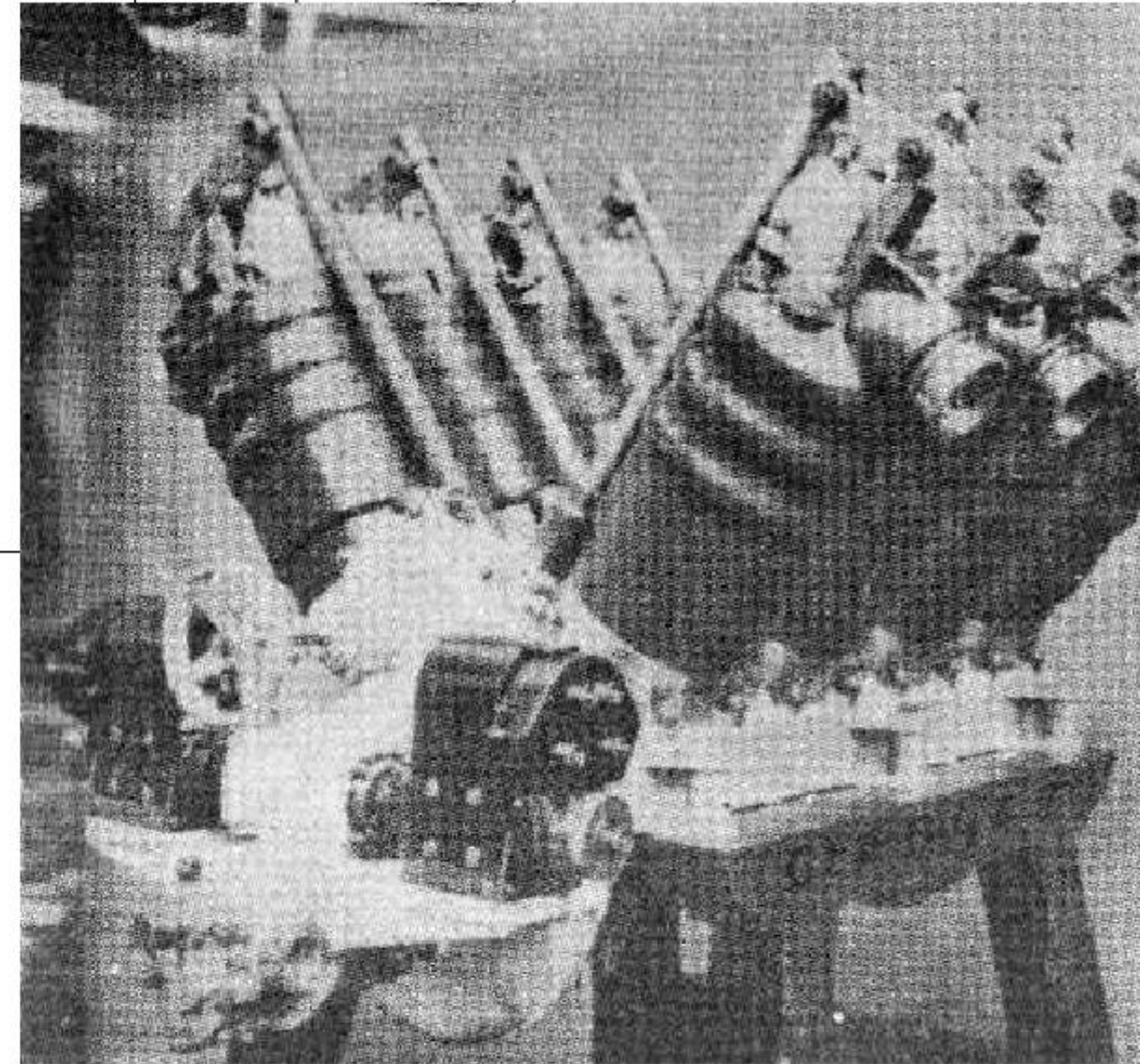

De Dion.

200 h.p. Clerget.

## GNOME

Société des moteurs Gnome, 3 rue La Boétie, Paris.

## LABOR AVIATION.

50 h.p., 7 cyl., 115×120 (1200 r.p.m.) 165 lbs.

70 h.p., 7 cyl., 135×120 (1300 r.p.m.) 183 lbs.

80 h.p., 7 cyl., 124×140 (1200 r.p.m.) 191 lbs.

100 h.p., 14 cyl., 110×120 (1200 r.p.m.) 220 lbs.

140 h.p., 14 cyl., 130×120 (1200 r.p.m.) 286 lbs.

160 h.p., 14 cyl., 124×140 (1200 r.p.m.) 308 lbs.

Radial rotary, air-cooled.

H.T. magneto.

Automatic inlets.

Forced lubrication.

*Features.--*

Single crank pin

Steel cylinders turned from solid.

Single ignition point.

Gas admitted through hollow crank shaft to crank case, thence to pistons; oil enters in a similar way.

Nickel chrome crank shaft, ball bearings.

Steel crank case.

The 100 h.p. has seven cylinders behind seven others. Larger sizes ditto.

Older engines of 50-100 h.p. do not differ in general details.

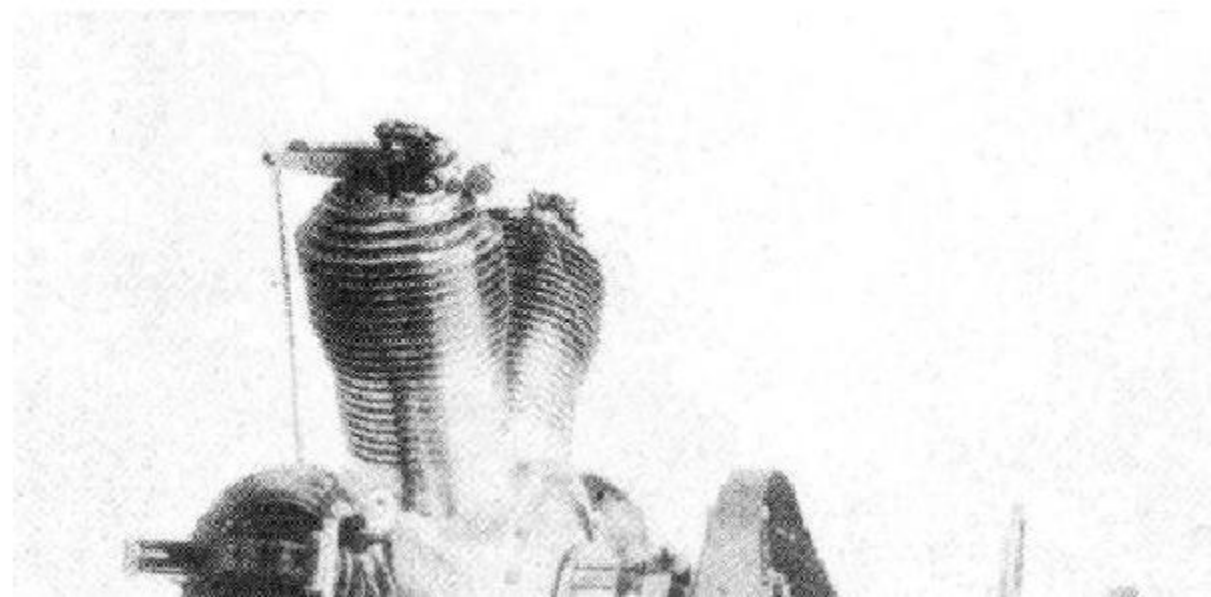

## PANHARD.

Société Panhard & Levassor, avenue d'Ivry, Paris.

## RENAULT

35-40 h.p., 4 cyl., 110×140 210 lbs.  
Automobiles Louis Renault, 15 rue Gustav-Sandoz, Billancourt (Seine)  
55 h.p., 6 cyl., 110×140 341 lbs.  
100 h.p., 8 cyl., 110×140 (1500 r.p.m.) 440 lbs.

Vertical, water-cooled.

H.T. magneto.

Mechanical inlets.

Pump lubrication.

*Features.--*

Cast-iron cylinders, jackets in casting.

Valves at side.

Cam shaft in crank case.

Nickel chrome crank shaft; white metal bearings.

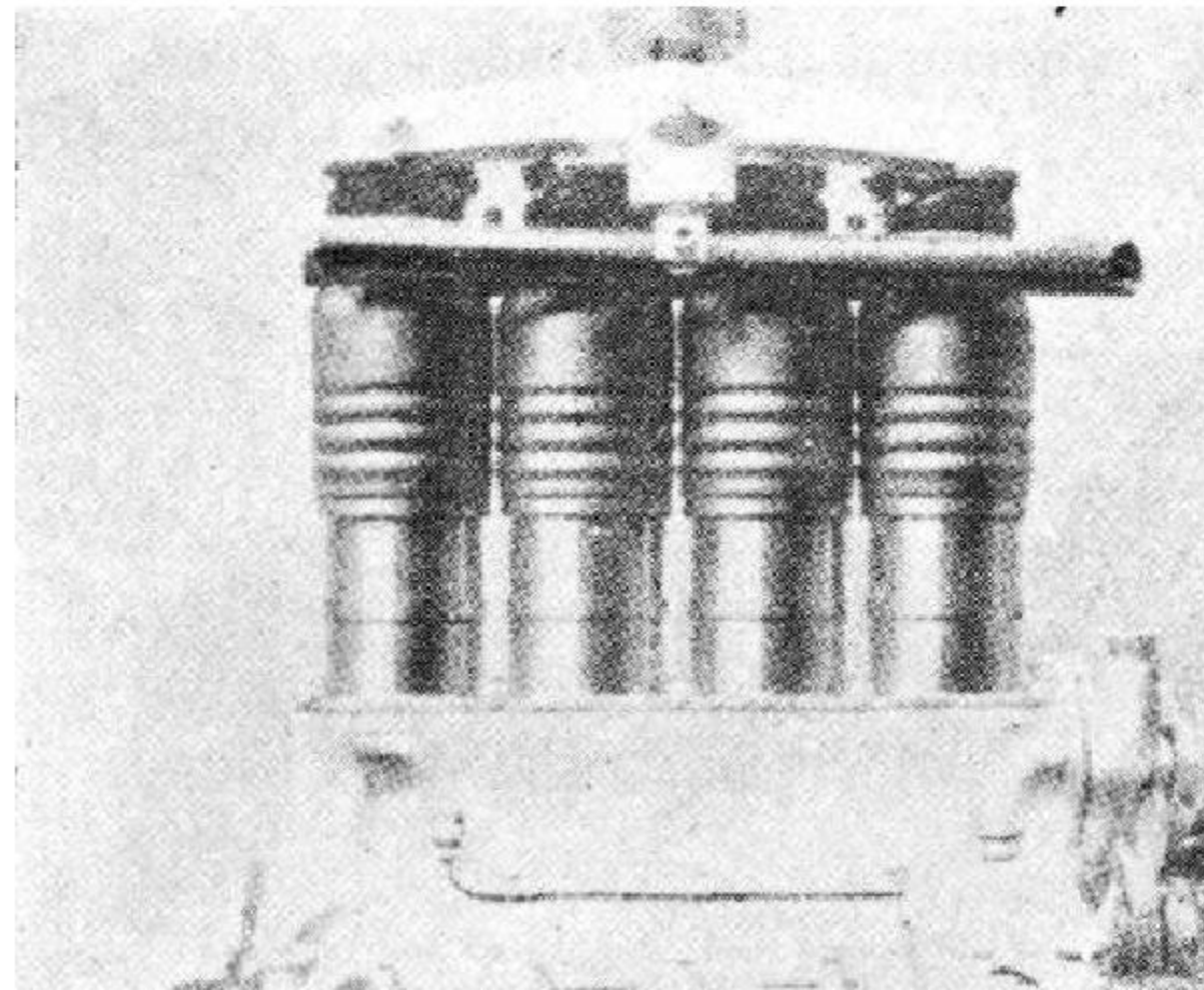

**R.E.P.**

Établissement Robert Ésnault Pelterie, 149 rue de Silly, Billancourt (Seine).

**ROSSEL-PEUGEOT.**

45 h.p., 5 cyl., 100×140 243 lbs.  
60 h.p., 5 cyl., 110×160 (1100 r.p.m.) 330 lbs.  
90 h.p., 7 cyl., 110×160 (1100 r.p.m.) 463 lbs.

Radial, air-cooled.

H.T. magneto and accumulators.

Mechanical inlets.

Forced lubrication.

*Features.--*

In the 7 cyl. the cylinders are in two planes, four being in front of the others.

The 5 cyl. engines are fan shape in one plane.

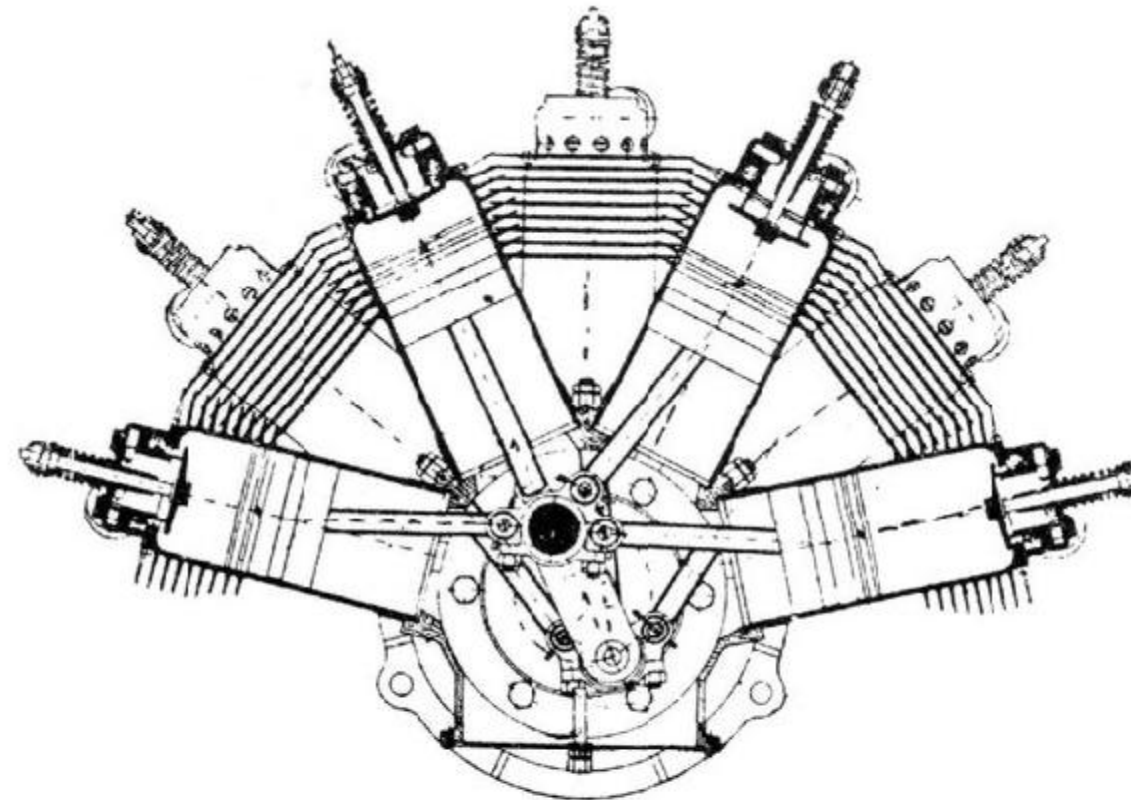

7 cylinder.

## VIALE.

Viale & Cie. 19 rue de la Mairie, Boulogne-sur-Seine (Seine).

30 h.p., 3 cyl., 105×130 (1250 r.p.m.) 165 lbs.  
50 h.p., 5 cyl., 105×130 (1250 r.p.m.) 199 lbs.  
70 h.p., 7 cyl., 105×130 (1250 r.p.m.) 254 lbs.  
100 h.p., 10 cyl., 105×130 (1250 r.p.m.) 320 lbs.

Radial, air-cooled.

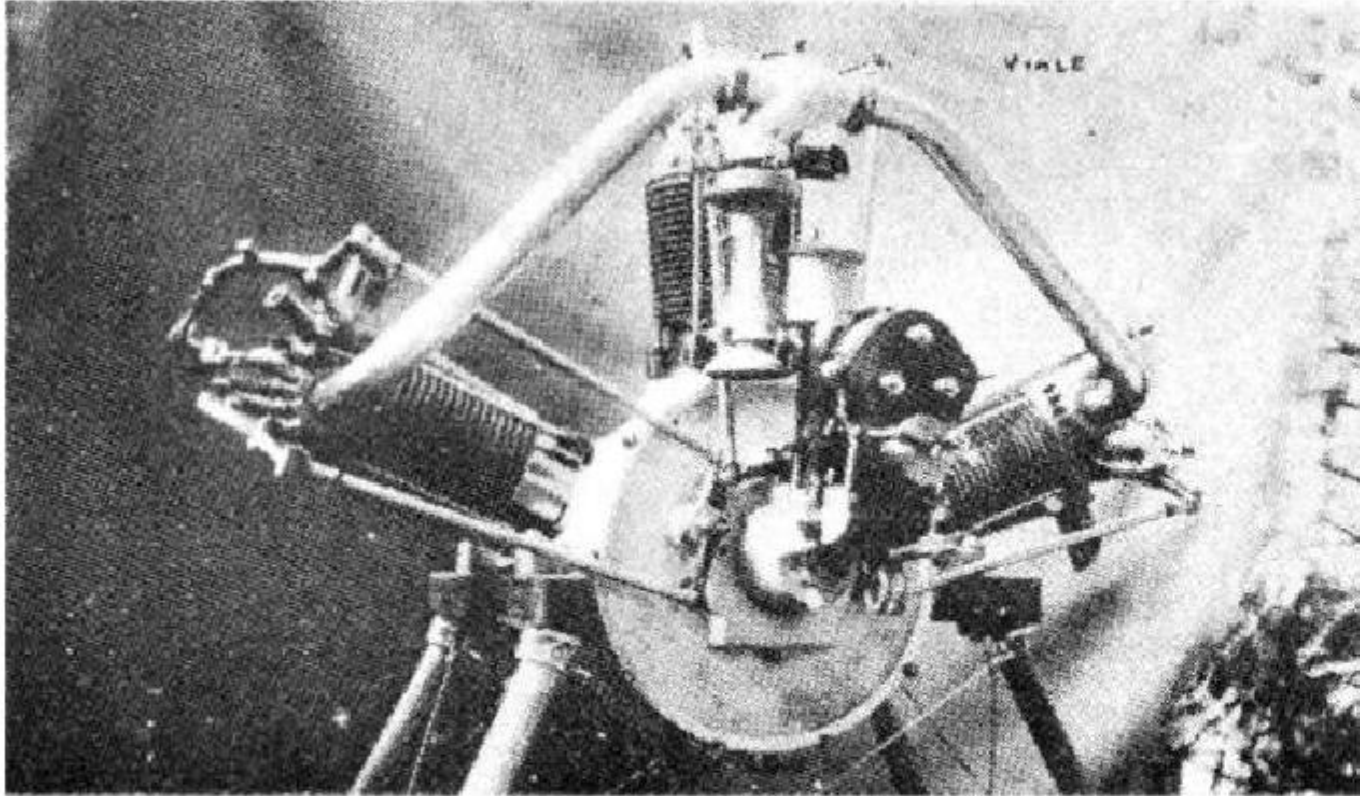

VIALE.

## VERDET.

## GERMAN.

55 h.p., 7 cyl., 112×140 (1100 r.p.m.) 176 lbs.  
Revised by Herr Ing. W. Isendahl.

Rotary, air-cooled.

**ARGUS.**

Argus-Motoren G.m.b.H., Flottenstrasse 39 and 40, Reinickendorf bei Berlin. Established 1900.

**BENZ.**

70 h.p., 4 cyl., 124×130 (1400 r.p.m.) 254 lbs.  
100 h.p., 4 cyl., 140×140 (1250 r.p.m.) 290 lbs.  
Benz & Cie, Mannheim.

150 h.p., 6 cyl., 140×140 (1250 r.p.m.) 353 lbs.

Vertical, water-cooled (pump).

H.T. magneto (Bosch).

Mechanical inlets.

*Features.--*

Cast-iron cylinders.

Cylinders in pairs.

Valves one side (single cam shaft).

Crank shaft on ball bearings, closed and hollow.

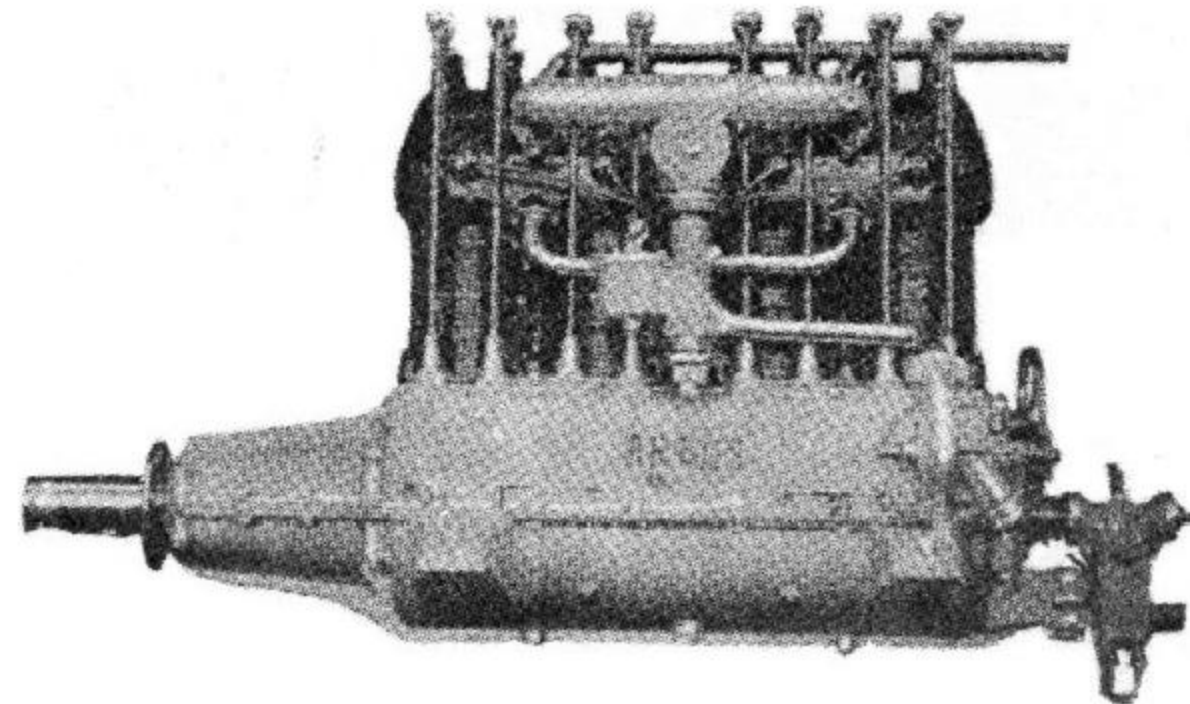

100 h.p.

24-30 h.p., 3 cyl., 110×130 (1500 r.p.m.) 100 lbs.  
30-40 h.p., 3 cyl., 120×140 (1400 r.p.m.) 120 lbs.  
35-45 h.p., 4 cyl., 110×130 (1500 r.p.m.)  
50-70 h.p., 4 cyl., 120×140 (1500 r.p.m.)  
50-60 h.p., 6 cyl., 110×130 (1500 r.p.m.)  
80-100 h.p., 6 cyl., 120×140 (1500 r.p.m.)

Radial air-cooled.

H.T. magneto (or 6 volt accumulator).

Automatic inlets.

Forced lubrication.

*Features.--*

Special metal cylinders.

Very large valve chambers.

Chrome nickel crankshaft and big ends.

Water-cooling fitted if required at a 10% increase of weight.

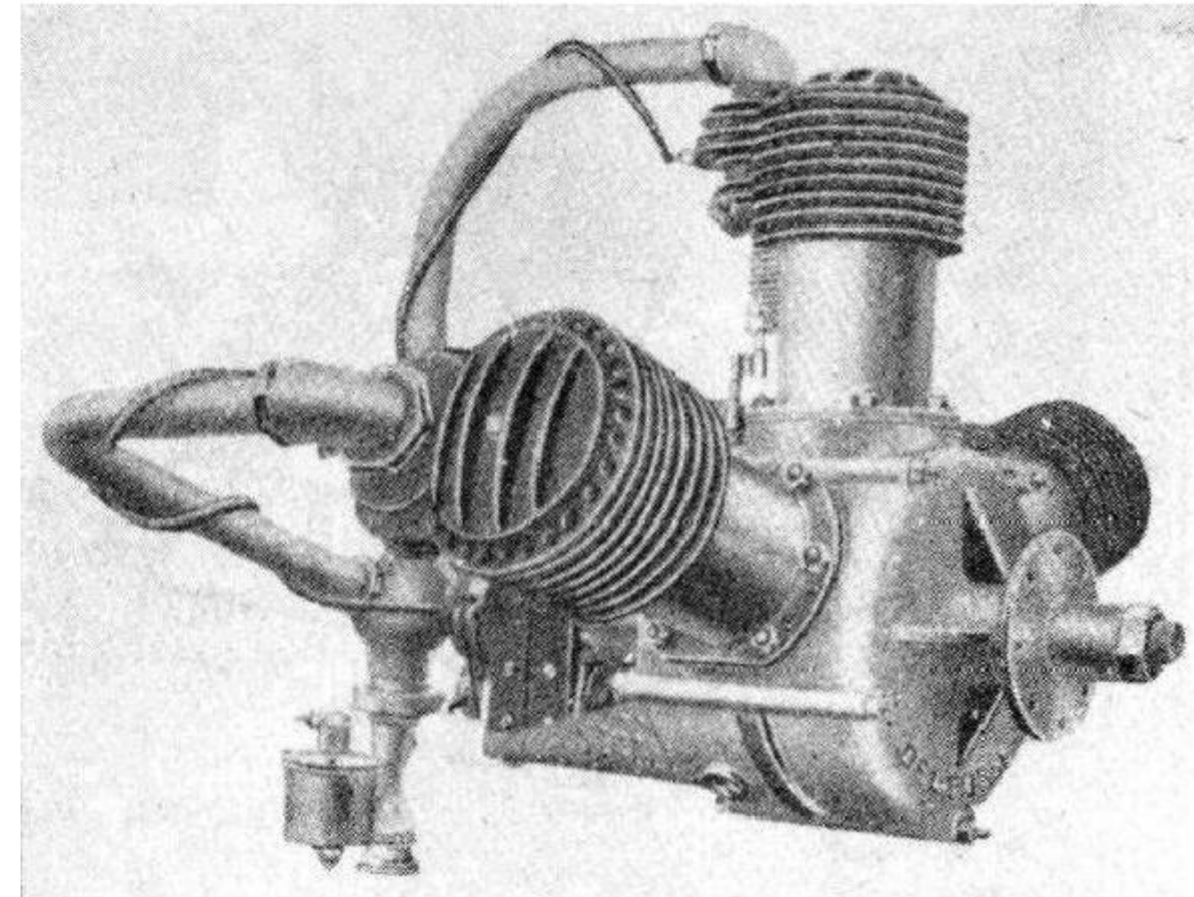

**HILZ.**  
Hilz Motorenfabrik G.m.b.H., Fürstenwallstr. 189, Düsseldorf.  
50 h.p., 4 cyl., 100×140 (1400 r.p.m.) 198 lbs.  
75 h.p., 4 cyl., 120×170 (1300 r.p.m.) 308 lbs.  
100 h.p., 4 cyl., 140×200 (1200 r.p.m.) 452 lbs.

Vertical, water-cooled (pump).

H.T. magneto (Bosch).

Mechanical inlets.

Forced lubrication.

*Features.--*

Cast-iron cylinders, copper jackets.

Single cylinders.

Overhead inlets (single cam shaft).

Crank shaft, hollow, on 3 metal bearings.

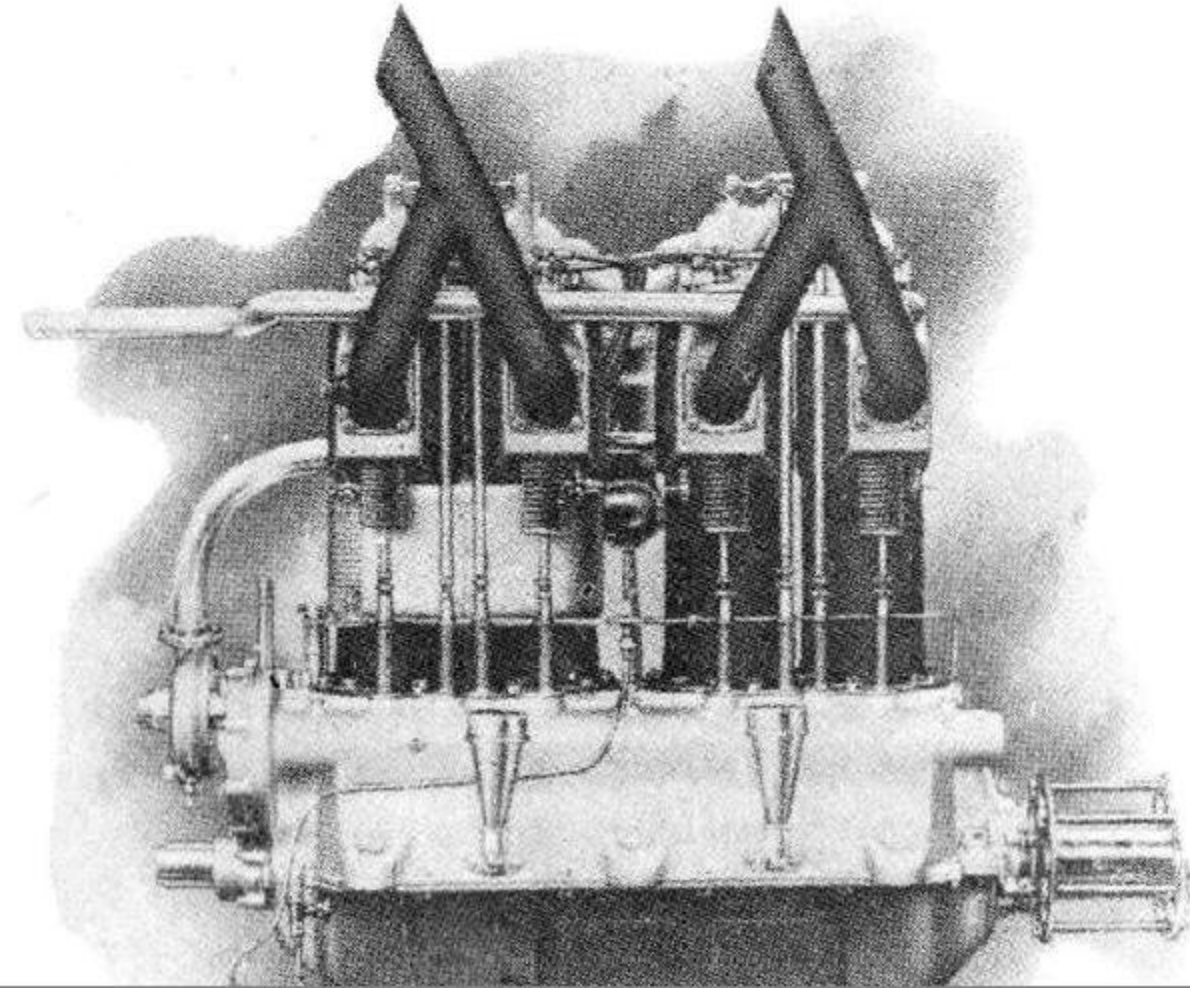



## MERCEDES-DAIMLER.

Daimler Motoren G.m.b.H., Stuttgart-Untertürkheim.

70 h.p., 4 cyl., 120×140 (1400 r.p.m.) 276 lbs.

70 h.p. (as above, but *inverted*) 298 lbs.

90 h.p., 6 cyl., 105×140 (1350 r.p.m.) 309 lbs.

Vertical, water-cooled (pump).

H.T. magneto (Eismann in the 70, two Bosch in the 90).

Mechanical inlets.

Forced lubrication.

*Features of the 70's--*

Cast-iron cylinders (in pairs).

Overhead valves.

Single cam shaft.

Crank shaft, hollow, on metal bearings.

*Features of the 90.--*

Steel cylinders, with steel jackets.

2 carburetters (Mercedes-Daimler), *otherwise as the 70's.*

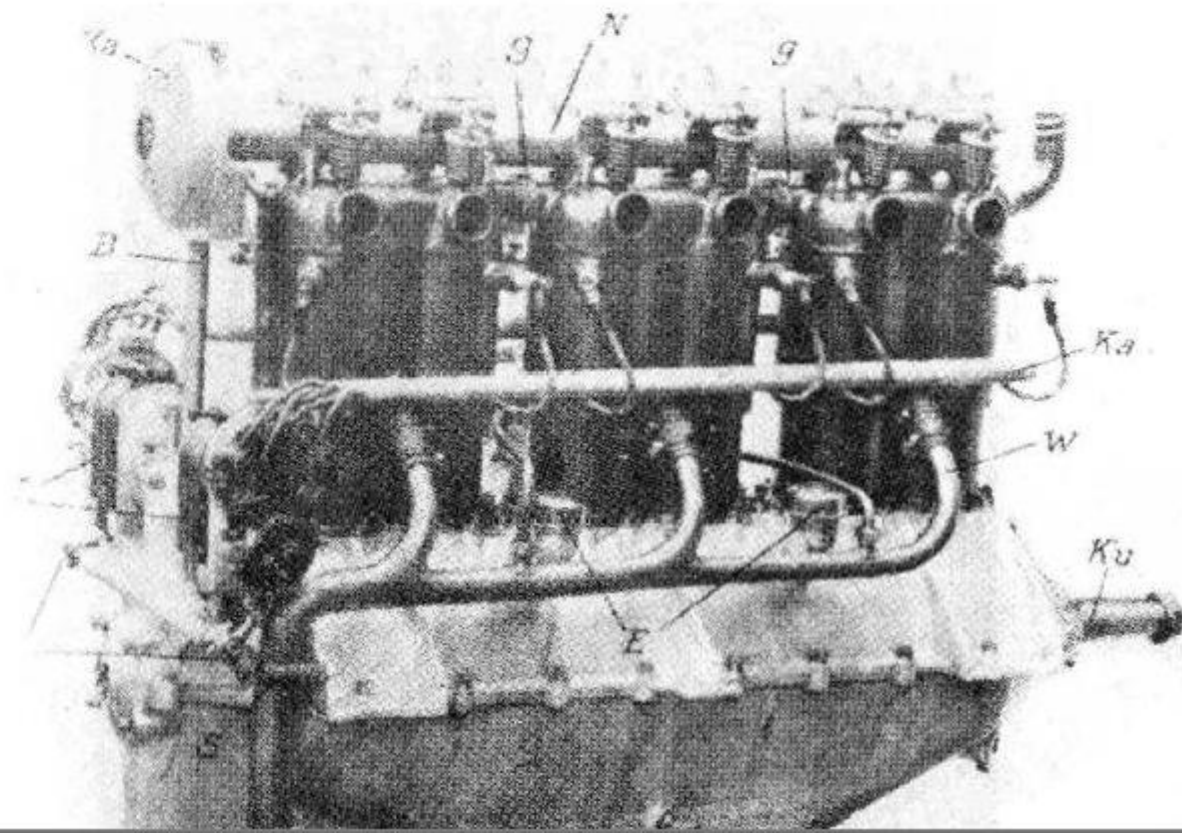

N.A.G.  
Neue Automobile Ges. m.b.H., Berlin-Oberschoneweide.

OTTO ("A.G.O.")  
60 h.p., 4 cyl., 118×100 (1400 r.p.m.) 254 lbs.  
Gustav Otto, G.m.b.H., Karlstrasse 72, Munich.  
95 h.p., 4 cyl., 135×165 (1350 r.p.m.) 353 lbs.

Vertical, water-cooled (pump).

H.T. magneto (Bosch), 2 in the 95 h.p.

Mechanical inlets.

Forced lubrication.

*Features.--*

Cast-iron cylinders, copper jackets.

Cylinders in pairs.

Single cam shaft.

Overhead valves.

Crank shaft, hollow, on 5 metal bearings.

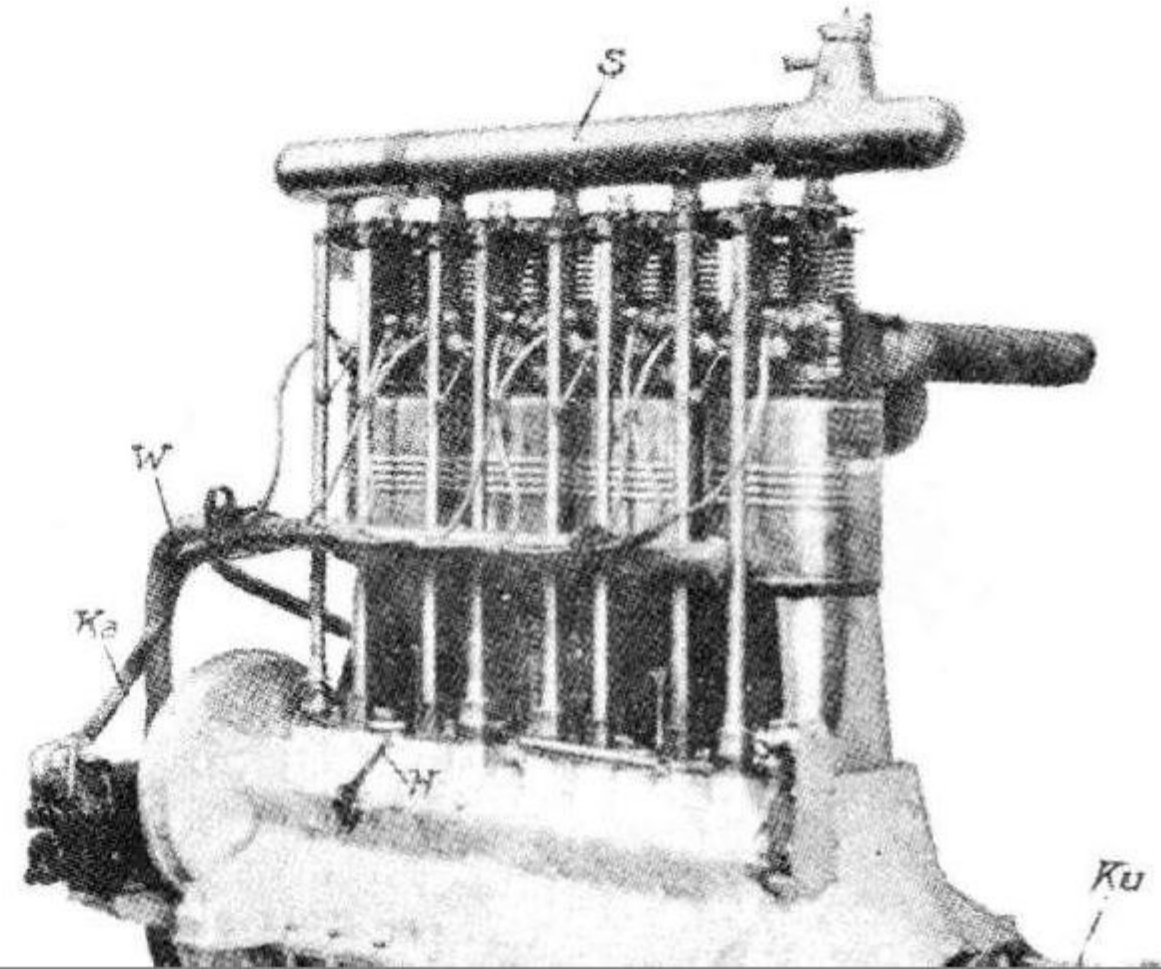

---

70 h.p., 7 cyl., 110×150 (1100 r.p.m.) 199 lbs.

90 h.p., 9 cyl., 110×150 (1100 r.p.m.) 243 lbs.

Rotary, air-cooled.

H.T. magneto.

Automatic inlets.

Forced lubrication (fresh oil).

*Features.--*

Steel cylinders.

Single cylinders.

Overhead valves.

Crank shaft, hollow, on ball bearings.

## ITALIAN.

Works of the Italian built  
Gnome engines.

50-55 h.p., 4 cyl., 115×140 (1500 r.p.m.) 397 lbs.

Vertical, water-cooled (pump).

H.T. magneto.

Mechanical inlets.

Forced lubrication.

*Features.--*

Cylinders in pairs.

Overhead inlets.

Automatic carburetter.

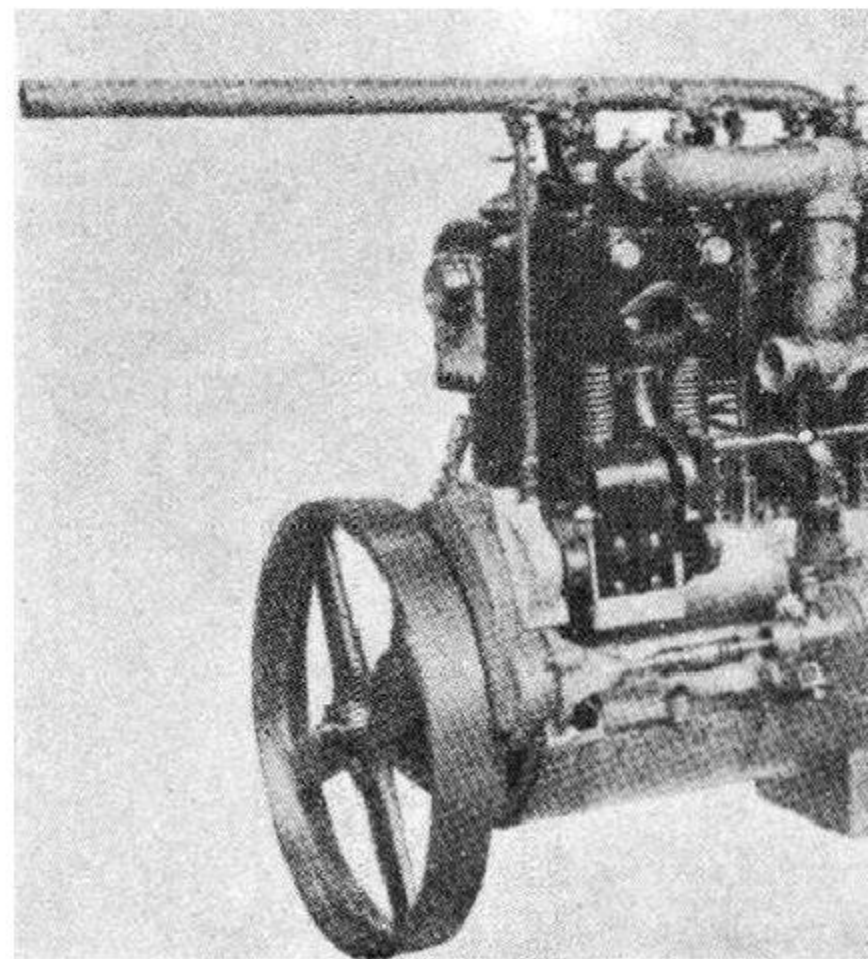

<p><b>CAPRONI &amp; FACCANONI.</b> Soc. di Aviazione Ing<sup>ri</sup> Caproni &amp; Faccanoni, Vizzola Ticino.</p>	<p><i>(Dirigibles only.)</i> <b>FIAT.</b> Fabbrica Italiano Automobile Torino, 30-35 Corso Dante, Turin (Torino).</p>	<p><i>(Dirigibles only.)</i> <b>ISOTTA-FRASCHINI.</b> Fabbrica Automobili Isotta-Fraschini, 79 Via Monte Rosa, Milan.</p>
<p>60 h.p., 6 cyl., 105×130 176 lbs. 120 h.p., 12 cyl., 105×130 ? lbs.</p> <p>Radial, air-cooled.</p> <p>H.T. magneto. Mechanical inlets. Forced lubrication.</p>	<p>60 h.p., 4 cyl., 150×200 (1200 r.p.m.) 220 lbs. 200 h.p., 4 cyl., 170×250 (1200 r.p.m.) 1443 lbs.</p> <p>Vertical.</p> <p>H.T. magneto and accumulators. Mechanical inlets. Forced lubrication.</p> <p><i>Features.--</i></p> <p style="padding-left: 40px;">Enclosed valves.</p> <p style="padding-left: 40px;">Single cast-iron cylinders.</p>	<p>100 h.p., 4 cyl., 130×180 ( r.p.m.) 662 lbs. 500 h.p., 8 cyl., 150×200 ( r.p.m.) 1543 lbs.</p> <p>Vertical.</p> <p>H.T. magneto. Mechanical inlets. Forced lubrication (pump).</p> <p><i>Features.--</i></p> <p style="padding-left: 40px;">Overhead inlets. Horizontal exhausts.</p> <p style="padding-left: 40px;">Special radiation.</p> <p style="padding-left: 40px;">Zenith carburetter.</p>
<p><b>GNOME.</b> Fab. Italiana Mot. Gnome, 73 Strada Venaria, Turin (Torino).</p>	<p><b>ITALA.</b> Itala Fabbrica Automobili, Barriera Orbassano, Turin (Torino).</p>	

**L. U. C. T.**  
Ladetto-Ubertalli &  
Cavalchini, Via Cavalli.-  
Angolo Via  
Circonvallazione Turin  
(Torino).

**S. P. A.**  
Società Ligure Piemontese Automobili, Barriera Crocetta, Turin.

50 h.p., 7 cyl., 110×120 ?  
lbs.  
80 h.p., 9 cyl., 110×120 ?  
lbs.  
100 h.p., 9 cyl., 122×150 ?  
lbs.

40-50 h.p., 4 cyl., 95×150 (1200 r.p.m.) 199 lbs.

Horizontal, water-cooled (pump).

H.T. magneto and accumulators.

Mechanical inlets.

Forced lubrication.

Rotary, air-cooled.

H.T. magneto.

Mechanical inlets.

Forced lubrication.

*Features.--*

Two pistons per cylinder.

Ball bearings throughout.

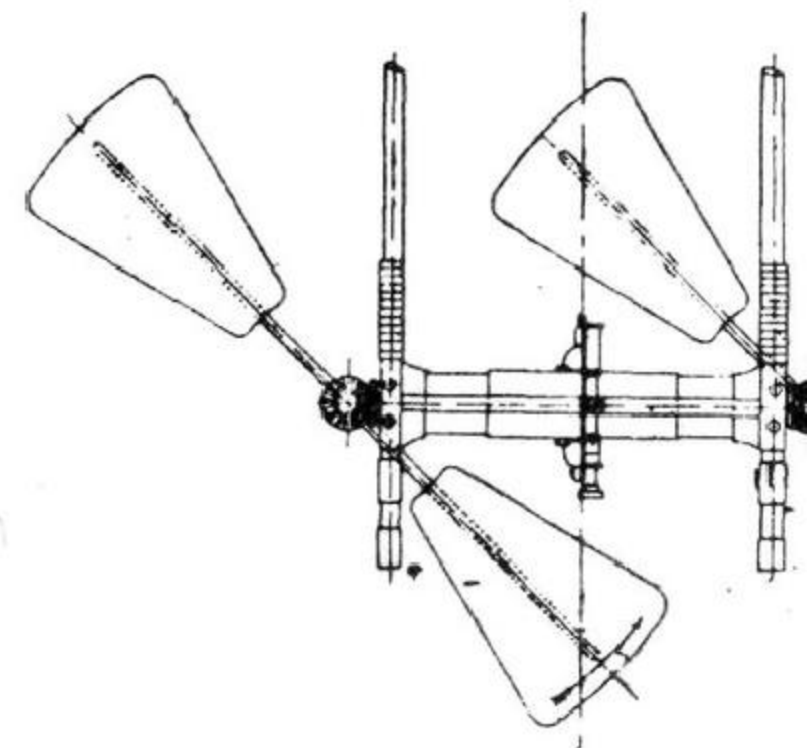
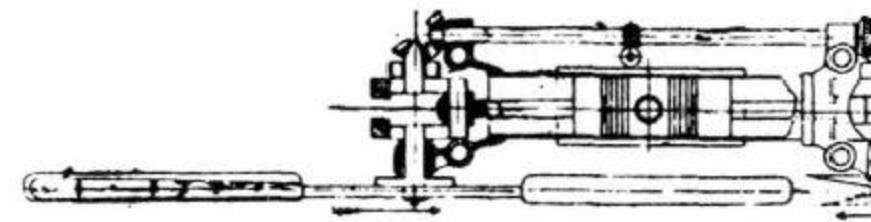

Dirigible engine.

There is also a vertical 160 h.p. dirigible engine.

## SWISS.

### OERLIKON.

Société Oerlikon Suisse de Machines Outils, Oerlikon.

55 h.p., 4 cyl., 100×200 (1200 r.p.m.) 176 lbs.

Horizontal opposed, water-cooled (pump).

H.T. magneto (2 circuits for 2 sets of plugs).

Mechanical inlets.

Forced lubrication.

*Features.--*

Steel cylinders (copper jackets).

Single cylinders.

Overhead valves.

Single cam shaft.

2 carburetters (one for each pair of cylinders).

Crank shaft, solid, on ball bearings.

Open crank case.

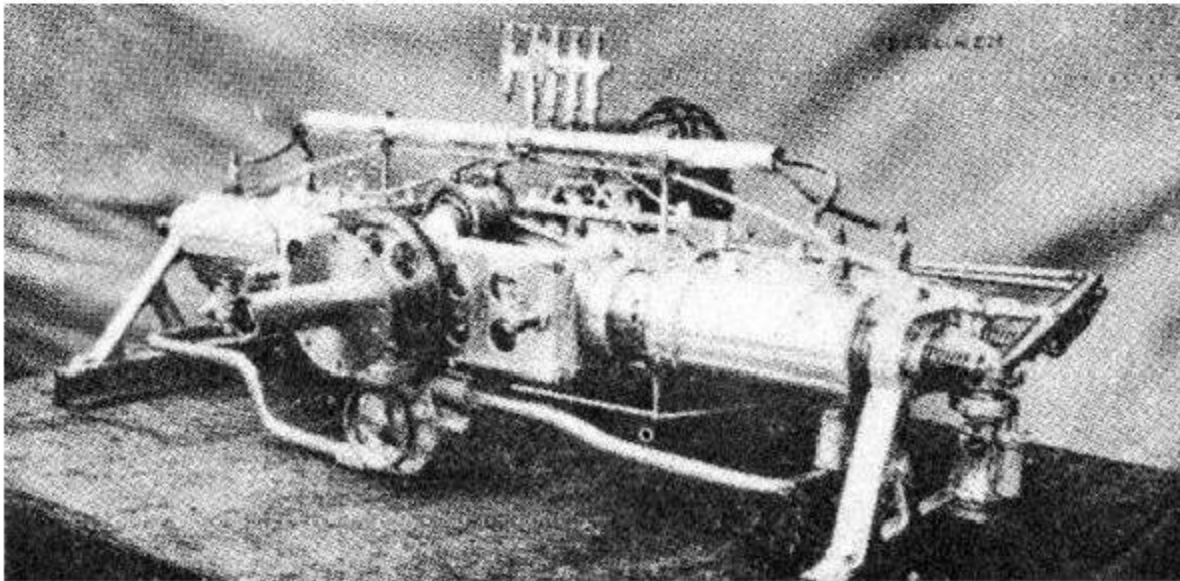

## U.S.A.

### ADAMS-FARWELL.

21, Athol Street, Dubuque, Iowa.

36 h.p., 5 cyl., 102×88 (1200 r.p.m.) 97 lbs.  
63 h.p., 5 cyl., 142×127 (1200 r.p.m.) 250 lbs.  
72 h.p., 5 cyl., 152×152 285 lbs.

Rotary horizontal.

H.T. magneto.  
Special valves.

*Features.--*

No flywheel.

All valves in cylinder head, actuated by a single push and pull lever worked by a single cam. Valves close outwardly and are held shut by centrifugal force.

Variable lift.

Exhaust ports.

Mechanical oil feed.

Engine weights are "fully complete."

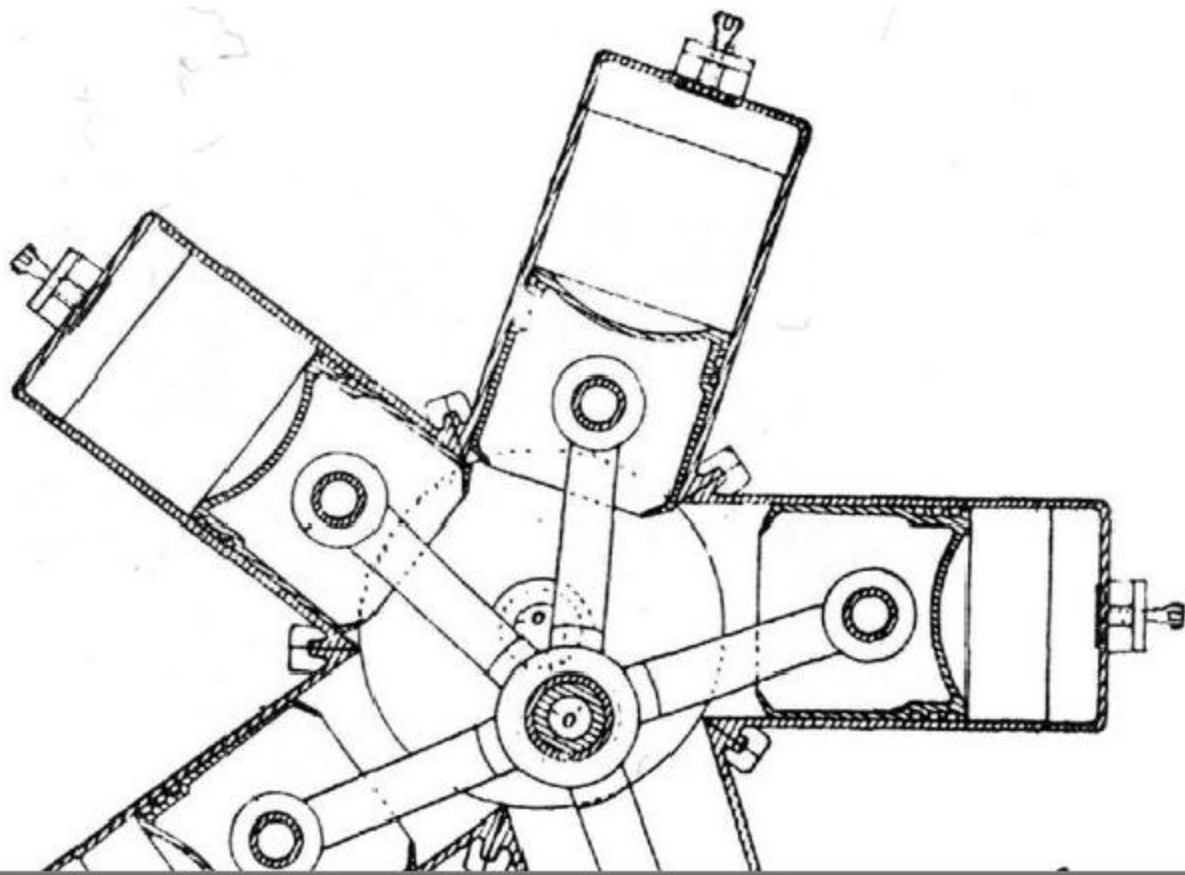

50 h.p., 6 cyl., 113×125 (1230 r.p.m.) 250 lbs.  
100 h.p., 6 cyl., 137×125 275 lbs.  
Aerial Navigation Co. of America, Girard, Kansas.

CALL.

Radial. The 50 is air-cooled, the 100 water-cooled.

50 h.p., 2 cyl., 150×131 185 lbs.  
100 h.p., 4 cyl. 325 lbs.

Horizontal opposed, water-cooled.

Mechanical inlets.  
Magneto ignition (Bosch).  
Special silencer.  
Vanadium iron cylinders.  
Forced lubrication.

*Features.--*

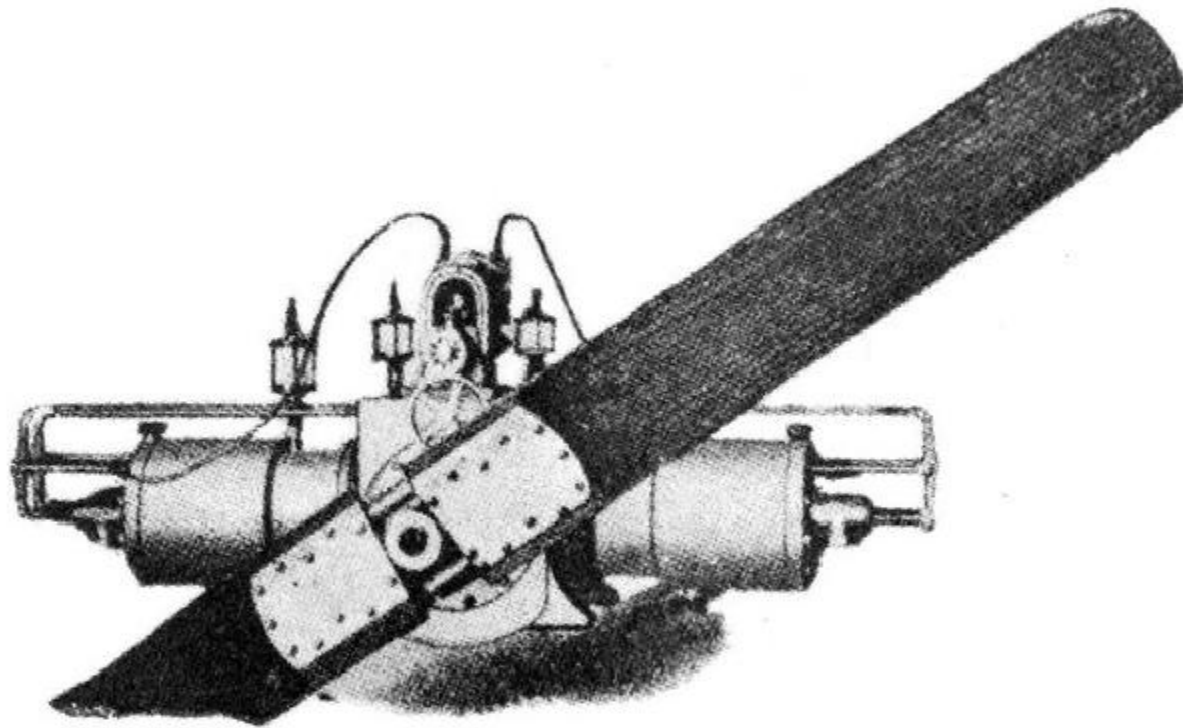

### DETROIT AEROPLANE CO.

40 h.p., 4 cyl., (1100 r.p.m.) ? lbs.  
75 h.p., 8 cyl., 100×100 (1100 r.p.m.) 250 lbs.

also

60 h.p., 6 cyl., (1350 r.p.m.) ? lbs.

40 and 75, V shape, water-cooled (pump).

60, vertical water-cooled (pump).

H.T. magneto (Bosch dual).  
Mechanical inlets.  
Splash and forced lubrication.

*Features.--*

Single cylinders, copper jackets.

All valves in cylinder heads, actuated by rocking levers from single cam shaft.

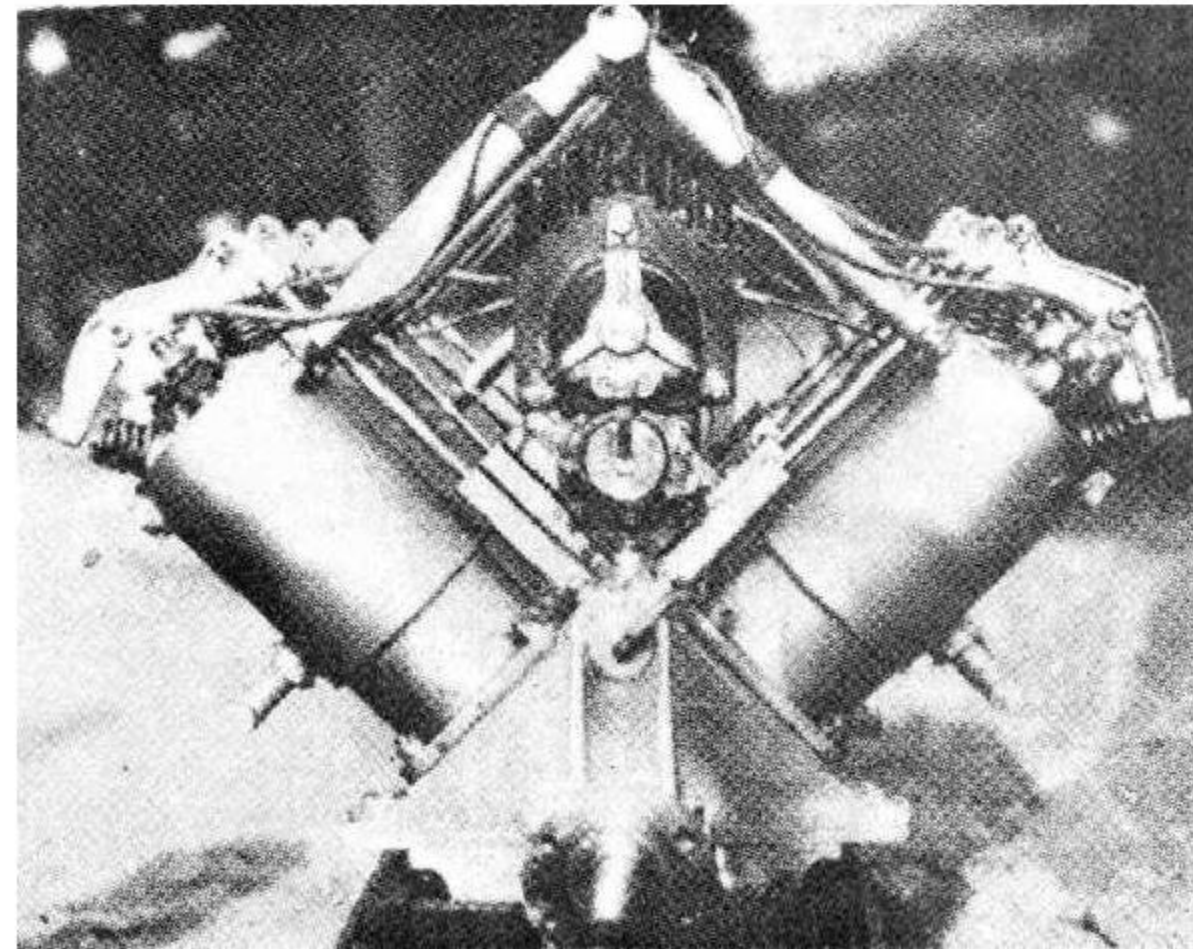



30-40 h.p., 2 cyl., 127×127 (1200 r.p.m.) 110 lbs.

2 cycle horizontal, air-cooled.

H.T. magneto.

Automatic inlets.

Splash lubrication.

*Features.--*

All valves in cylinder heads operated by a single cam.

Valves easily detached.

Very large valves.

Schebler carburetter.

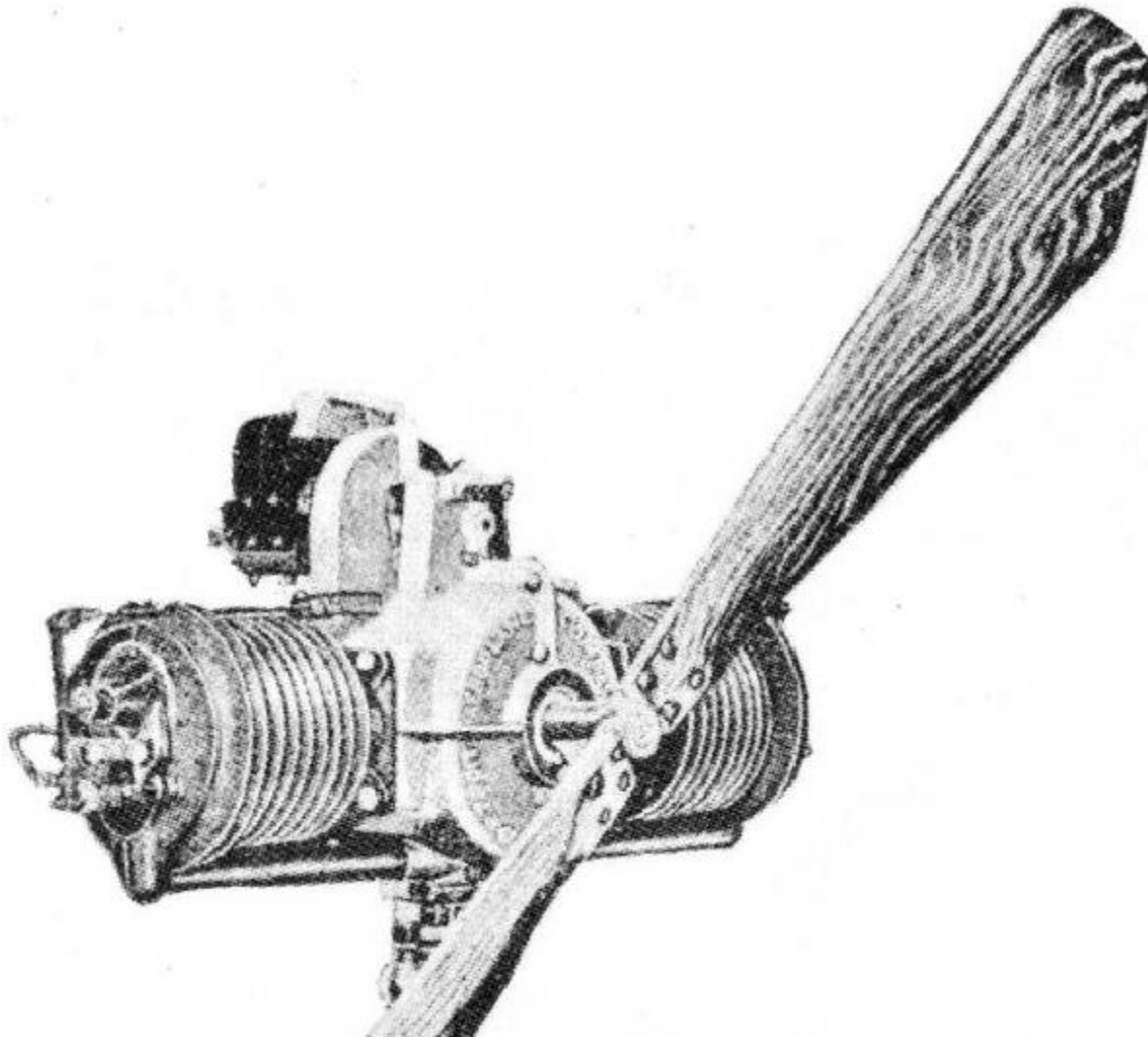

**HALL-SCOTT.**

40 h.p., 4 cyl., 123×114 198 lbs.  
Hall-Scott Motor Car Co., San Francisco, Cal.  
60 h.p., 6 cyl., 123×114 257 lbs.

Vertical, water-cooled. Valveless. Oil in gas.

*Features.--*Extra large bearings.

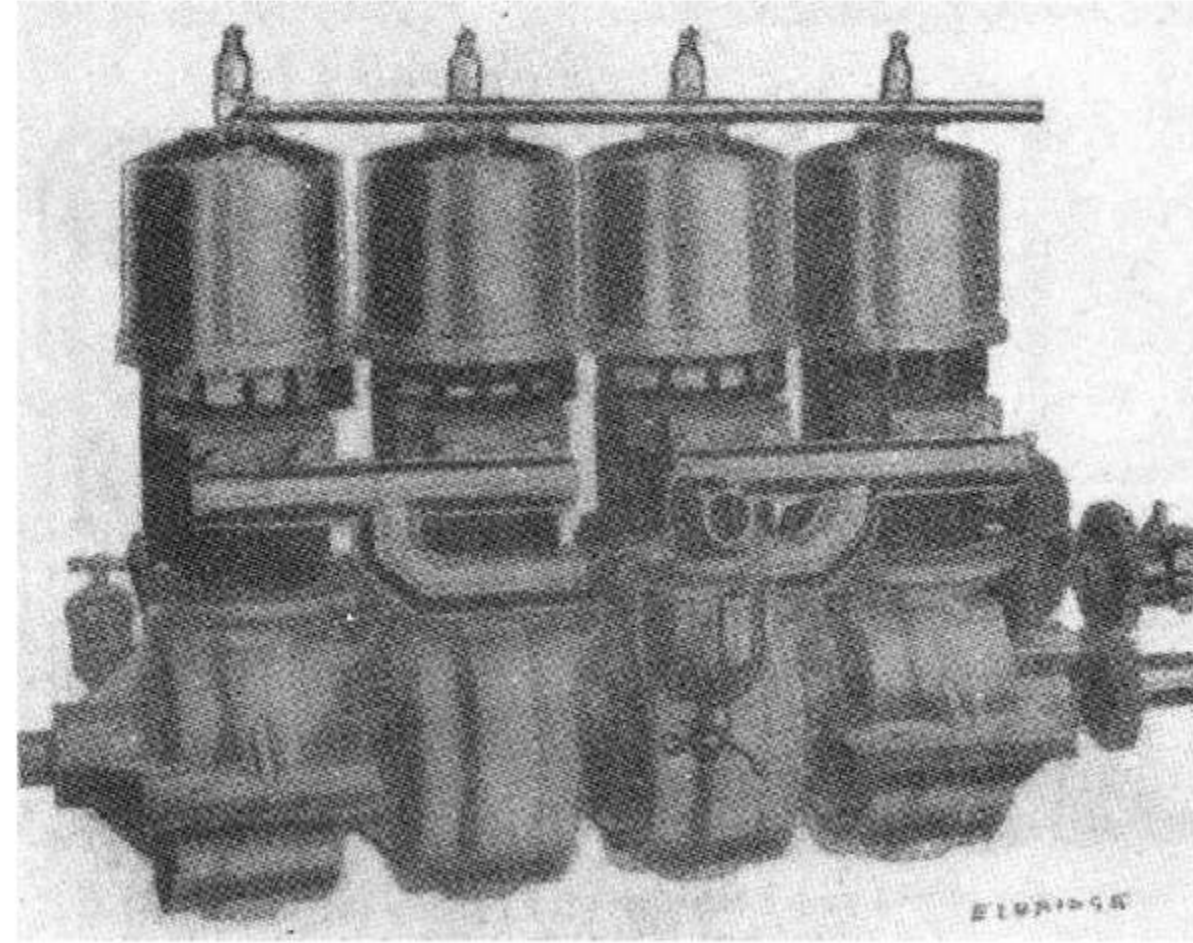

30 h.p., 4 cyl., 100×100 142 lbs.  
 40 h.p., 4 cyl., 100×125 150 lbs.  
 60 h.p., 8 cyl., 100×100 235 lbs.  
 80 h.p., 8 cyl., 100×125 270 lbs.  
 100 h.p. ? lbs.

First two are vertical, the others  
 V type, water-cooled (pump).

H.T. magneto (Bosch).

Mechanical inlets.

Pump lubrication.

Cast-iron cylinders.

All valves overhead.

Copper jacketed.

Special Stromberg carburetter.

Special radiators.

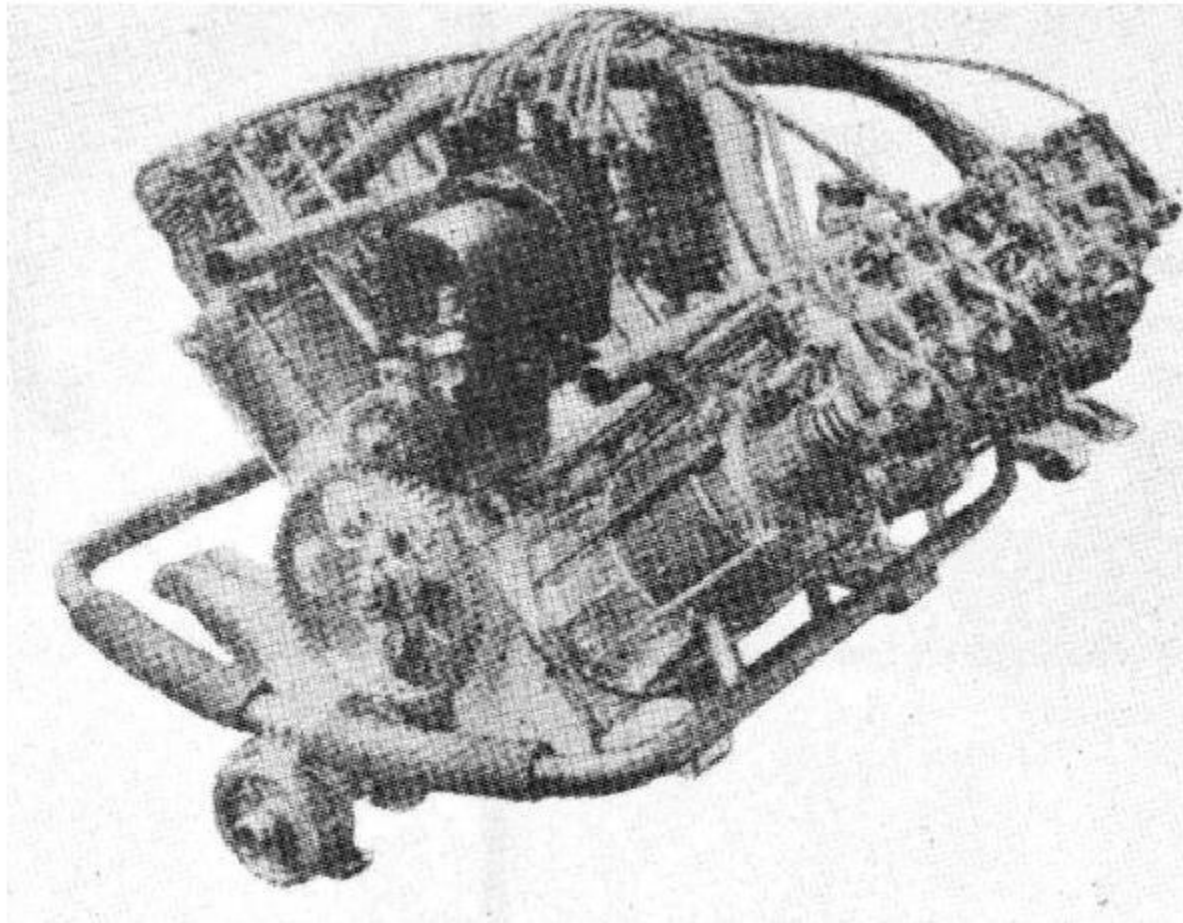

**KIRKHAM.**  
 1912 models.  
 C. Kirkham, Savona, N.Y.

35 h.p., D 4 cyl., 100×113 ? lbs.

45 h.p., E 6 cyl., 105×120 (1400 r.p.m.) 180 lbs.

65 h.p., 6 cyl., 105×120 (1300 r.p.m.) 235 lbs.

75 h.p., 6 cyl., × (1300 r.p.m.) 255 lbs. 1913 models:

110 h.p., 8 cyl., 105×120 (1200 r.p.m.) 310 lbs.

16 h.p., G 2 cyl. lbs.

35 h.p., I 4 cyl. lbs.

55 h.p., H 6 cyl. lbs.

75 h.p., J 8 cyl. lbs.

Forced lubrication.

Vertical, air-cooled.

Features.--

H.T. magneto.

Mechanical inlets.

Pump lubrication.

Features.--

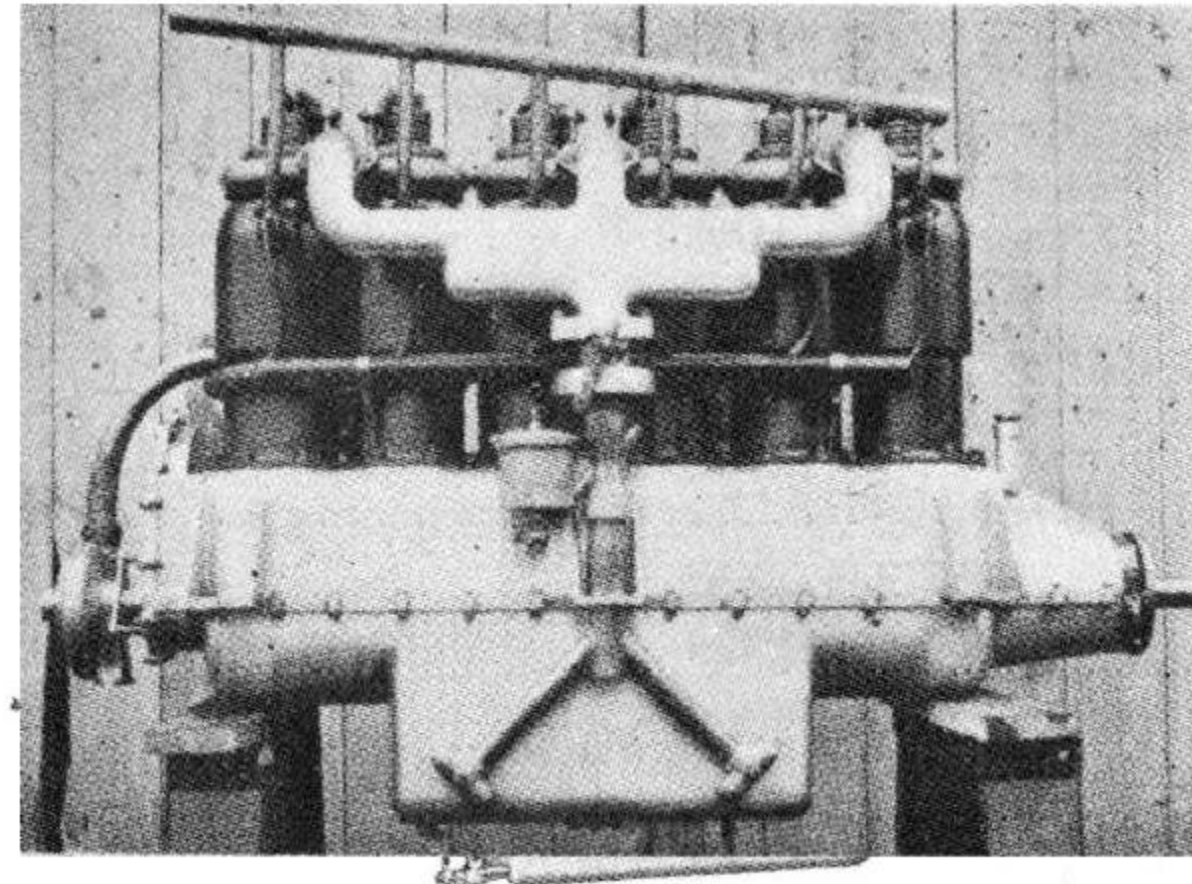

**ROBERTS.**

Roberts Motor Co., Sandusky, Ohio.

50 h.p., 4 cyl., 113×125 165 lbs.  
75 h.p., 6 cyl., 113×125 (1100 r.p.m.) 240 lbs.

Vertical, 2 cycle, water-cooled (pump).

H.T. magneto.  
Rotary inlets.  
Forced lubrication.

*Features.--*

- 2 carburetters.
- Special magneto advance.
- Babbit bearings.
- Very large hollow crank shaft.
- Special metal cylinders (aerolite).
- Special by-pass.
- Rotary inlets.

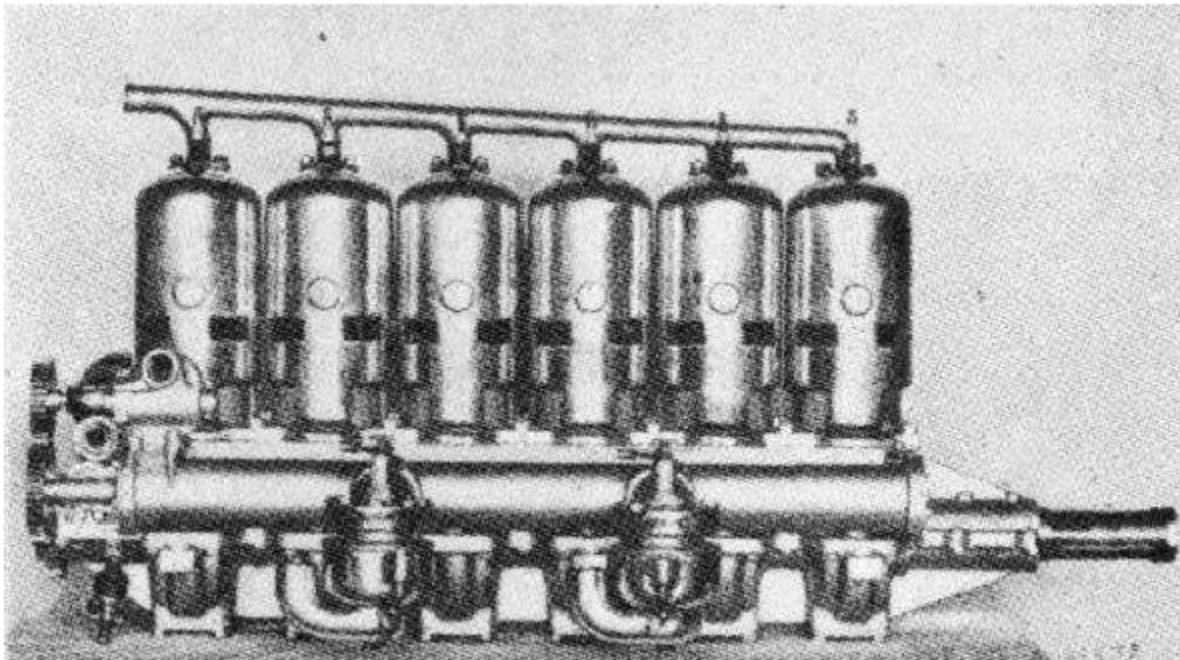

**WELLES & ADAMS.**  
Wells & Adams, Bath, N.Y.

40 h.p., 4 cyl., 113×113 (1300 r.p.m.) 200 lbs.  
60 h.p., 6 cyl., 113×113 ( r.p.m.) 285 lbs.  
Vertical, water-cooled (pump).

H.T. magneto (Mea).  
H.T. magneto.  
Mechanical inlets.  
Mechanical inlets (overhead).  
Pressure feed lubrication.  
Forced lubrication.

*Features.--*  
*Features.--*

- Semi-steel cylinders (jackets cast with them).
- Single cylinders (large brass jackets).
- Single cylinders.
- Double plugs.
- Single cam shaft.
- No valve cages.
- No overhead valves.
- Chrome nickel crank shaft, on 5 bearings.
- Exhaust valve lifters.

Note: Nickel steel hollow crank shaft (5 bearings in the 4 cyl., 7 in the 6 cyl.)

There are a good many other U.S. engines of little or no account. The majority of these are merely more or less accurate copies of well-known European engines, and none of them have any vogue.

**WRIGHT.**  
The Wright Co., Dayton, Ohio.

## Part D.

## **AERIAL "WHO'S WHO," DIRECTORY & INDICES.**

**Note.**—So far as possible the directory lists are exhaustive for the entire world. Anyone accidentally omitted is requested to communicate with the Manager, *All the World's Air-craft*, 5, Queen Victoria Street, London, E.C.

### **SUB-HEADS OF THIS SECTION.**

#### "WHO'S WHO" IN AVIATION.

#### **DIRECTORY:**

CARBURETTORS.

FABRICS.

GARMENTS FOR AVIATION.

HANGAR AND SHED BUILDERS.

INSURANCE.

LUBRICANTS.

MAGNETOS.

MISCELLANEOUS ACCESSORIES.

PACKERS AND SHIPPERS.

PATENT AGENTS.

PETROL.

PROPELLERS.

RADIATORS.

#### **INDICES:**

ALPHABETICAL AEROPLANES.

ALPHABETICAL DIRIGIBLE TYPES.

## AERIAL WHO'S WHO.

ADER (Clement), Chateau de Ribonnet, Beaumont-sur-Leze (Haute-Garonne, France). Born 1841. Officer Leg. d'Hon. Experimented from 1892. His *Avion* flew 300 metres at Satory, 12th October, 1897. This was the first flight ever made by a power machine in Europe. One of his early machines is in the *Arts et Metiers* Museum, Paris.

ALEXANDER (H. I. H. Grand Duke), Michailovitch of Russia, Xenia Palace, St. Petersburg. Born 1866. Admiral of the Russian Navy. Prime mover in anything having to do with aviation in Russia.

ALEXANDER (Patrick Y.), 2 Whitehall Court, London, S.W. Donor of the £1000 Patrick Alexander prize for British Aerial engines. Founder and supporter of various aerial clubs and societies.

ANDRE (Ing. A.), 82 Rue d'Amsterdam, Paris. Editor *Revue Francaise de Construction Automobile et Aeronautique*. Writer on aviation. Experimenter.

ARBUTHNOT (C. B.) (Major General H. T.) Chairman of the Aerial League of the British Empire.

ARCHDEACON (Ernest), 77 Rue de Prony, Paris. Born 1863. Chev. Legion d'honneur. Vice-President *Ligue Nat. Aeriennne*. Barrister. From 1884 made balloon ascents. In 1904 made glider experiments with Gabriel Voisin. Giver of the Archdeacon Cup, won by Santos Dumont, 29th October, 1906. Also part giver with Deutsch of the Deutsch-Archdeacon prize, for a Kilometre flight, closed circuit, won by Henry Farman, 13th January, 1908.

ARNOUX (Réne), 45 Rue du Ranelagh, Paris. Born 1858. Vice-President Tech. Com. A.C.F. Designer of the electric motor of the *Tissandier* dirigible, 1882. Member Soc. Civil Eng. and Soc. Internat. Elec. Contributor to *Omnia*, etc. Inventor of the *Arnoux* biplane.

ATTWOOD (Harry). Well-known American aviator. In August, 1911, covered 1,435 miles in eight days.

AUFFM-ORDT. (Swiss). 2 Avenue Hoche, Paris. Pioneer Aviator.

AVERY, American pioneer aviator, associated with Herring, Chanute, and others.

BACON (*late Rev.*), British prominent aeronaut and lecturer.

BACON (Miss), daughter of the above. Aeronaut and lecturer.

BADEN-POWELL (Major, B.), F.R.A.S., F.R. Met. Soc., late Scots Guards. 32 Prince's Gate, London, S.W. Inventor of the Baden-Powell Box Kite. President of the Aeronautical Society from 1902 to 1909. Early experimenter and investigator with aeroplanes. Lecturer. Editor of *Aeronautics*.

BALDWIN (Capt. Thomas S.), 78 Maddison Square, New York. Well known U.S. Aeronaut of many years standing. Invented the *Baldwin* dirigible.

BALSAN (Jacques), 52 Quai Debilly, Paris. Born 1868. Aeronaut from 1905. Made an altitude record of 8,558 metres. In 1906 went by balloon, Paris to England. Vice-President *Aero Club de France*.

BANNERMAN (Major Sir Alexander, Bart.) In command of the British Army Air Battalion, 1911.

BARBER. British. Aeronautical Syndicate, 1909-12. *Valkyrie* type, etc., etc.

BARNWELL. British. Instructor 1912, Vicker's School.

BARRA. Well known French aviator.

BASENACH. German. Associated with Major Gross in producing the *M* type German dirigibles.

BARTON (Dr.) Built the first British dirigible in 1904. Capacity, 235,000 c.f.

BATHIAT (Georges). Frenchman. After only one hour's tuition at the Hanriot School, secured his certificate at Rheims, October, 1910. Brother of the Bathiat who flew a *Breguet*.

BAUMANN (Otto), Berlin. Second German to fly.

BAUMANN. French. Instructor at the Ewen School in 1912.

BEACHEY (Lincoln). American subject. In August, 1911, reached 11,578 feet (3,527 m.)—world's record to that date. Flew Niagara, 27th June, 1911, in a *Curtiss*.

BEATTY (George W.) American aviator. At the Chicago meet, August, 1911, he made the world's passenger flight duration trip in 3 hours, 42 minutes, 22 seconds. Also made American records for 2 man altitude 3080 feet and 3 man duration on a *Wright*.

BECKE (Captain). British Army. In December, 1912, made a (to that date) record flight—Flamborough to Plymouth, and later back again—4½ hours out; 2 hours back, excluding landings en route.

BEESE (Nellie). First German lady to get her pilot certificate, which she did on a *Rumpler*.

BELL (Dr. Alexander Graham Bell). Canadian. One of the founders of the Aerial Exp. Assoc. in U.S.A. Began experiments 1894. Inventor of the Tetratedal, etc.

BENDALL. British. Instructor Bristol School at Brooklands, 1912.

BERGET (Alphonse). French subject. Professor Inst. Oceanographique. Past President Soc. Francaise de Nav. Ae. Author of *La Conquete de L'Air*.

BERNARD. French. Tester for *Farmans* 1912-13.

BERRIMAN (A. E.) British. 44, St. Martin's Lane, London, W.C. Technical editor of *Flight*. Author of *Principles of Flight*, etc., etc.

BERSON (Prof. Arthur), Hauptstrasse 9, Lehlendorp, Germany. Born 1859. Austrian. Well-known author on meteorological and similar subjects affecting aviation.

BESANCON (Georges), 35 Rue Francois I., Paris. Born 1866. Chev. Leg. d'Hon. Editor of *L'Aerophile*. Secretary Ae. C.F. Experimented with balloons from 1886 onward.

BESSONNEAU (J. B. Lieut. de reserve), 29 rue de Louvre, Paris. French. Born 1880. Pioneer aviation helper. Produced special steel cables of high resistance; also the well known Besson-neau *hangars demontables*. Organised the first town-to-town flights, 1910; also first Grand Prix, 1912.

BEZOLD (Professor Wilhelm Von), Director of the Meteorological Institute, Berlin, etc. Author of several works on aeronautics, etc.

BISS (Gerald), British, 1, Melina Place, Grove End Road, London, N.W. Automobile correspondent of the *Standard*. Aviation expert.

BLANCHARD. Frenchman. 1753-1809. First man to cross the English Channel in a balloon (1781).

BLAND (Lillian E., Miss), Carnmoney, Belfast, Ireland. First woman aviator to design and build her own machine, *The Mayfly*. Has since ceased.

BLERIOT (Louis), 56 Boulevard Maillot, Paris. Chev. Legion d'Honneur. Inventor of the *Bleriot* monoplane. Pioneer. Experimented from 1906. Has had more falls than any other aviators. First man to fly the Channel, which he did in *Bleriot XI.*, 25th July, 1909. Member, Com. d'Aviation of the Ae. C.F.

BIELOVUCIC. Peruvian. Flew the Alps, 1912. Well known aviator.

BISS (Gerald). 1, Melina Place, Grove End Road, London, N.W. Well-known writer on automobile and aviation.

BOCKLIN. Swiss. 1827-1901. In 1850 became interested in aviation. In 1881 built gliders and a model aeroplane. Triplane, 1881. Biplanes, 1882-1887. In 1888 a monoplane with electric motor.

BOLOTOFF (Prince), Reigate Priory, Reigate, England. Russian subject. Pioneer aviator.

BOOM (J. A.) Editor of the *De Luchtvaart*, Ged. Aude gracht 144, Haarlem.

BORGNIS (Achille), 48 Rue d'Université, Paris. Early experimenter and inventor. Vice-President of the Com. d'Aviation Aeronautiques Club de France. Member Ae. C.F. (See aviators.)

BOOTHBY (Lieut. F. L. M.) British Navy. Served on board the *Hermione* when she was mother ship for aviation and aeronautics. Holds certificates for both aeroplanes and dirigibles.

BOSQUET (Chev. du), 8 Place de la Concorde, Paris. Chev. de l'Ordre de Leopold. Sec. Commission auto-aérienne.

BOUTTIEAUX (Col.) In command French military aviation, 1911-13.

BRACKE (Albert), 11 Chemin de Saint-Denis, Casteau-Mons, Belgium. Engineer. Editor *L'Aero Mecanique*. Inventor of the *Bracke* and *Misson* monoplane. Author on aerial matters.

BREGUET (Louis Charles), 31 Rue Morel, Donai (Nord), France. Born 1880. Began experimenting June, 1906, and in July, 1908, his gyroplane flew 20 yards at a height of 14 feet. President de la Section du Nord de la Ligue Nat. Aérienne.

BRERETON (J.). British. Instructor at British Deperdussin School, 1912.

BREWER (W.). Author of a standard technical work, *The Art of Aviation*. Formerly manager of Grahame-White & Co. Writer on aerial matters.

BRINDLEY (Oscar). American citizen. In August, 1911, he made 11,726 feet, at Chicago. These figures were afterwards stated to be incorrect, so the record was not allowed.

BROOKINS, U.S.A. Up to August, 1910, held world's height record, 6,338 feet (1,922 m.), made in a *Wright* at Atlantic City, U.S.A. Badly injured in an accident, August, 1910.

BUIST (A. Massac). Well-known British writer on aviation subjects. Technical contributor to *Morning Post*, *Country Life*, etc., etc.

BURGEAT (Captain). The first French Officer after Captain Ferber to take up flying. He purchased *Antoinette VI.*—the first *Antoinette* sold to the public.

BUSTEED (Harry). Australian. *Bristol* pilot in the British Military Competition, 1912.

BUTLER (Frank Hedges). F.R.G.S., 155 Regent Street, London, W. Founder of the R. Ae. C. Crossed the Channel in a Balloon 1905. Member Ae. C. F.

BUTTENSTEDT (Carl). 95a, Friedrichshaven Str, Berlin. Born 1845. Author of aviation works and early experimenter over many years. Designer of aeroplanes, etc.

CAILLETET (Louis Paul), 75 Boulevard S. Michel, Paris. Officer Leg. d'Hon. Doctor. President Ae. C. F.

CALDERARA (Lieut.). Italian Navy. Sent to France to study aviation in 1908. Has made many good flights ever since. In 1912-13 produced a naval hydro-aeroplane of his own design.

CAPAZZA (Louis). Frenchman. Born 1862. Head of the Clement-Bayard Works.

CAPPER (Col.). Formerly in command of British Army aviation headquarters, Farnborough, 1909-10.

CASSINONE (Alexander), Nordpolstr. 2, Vienna. Leading Figure in Austrian aeronautical circles.

CASTAGNIERIS (Capt. Guido), 70 via della Muratte, Rome. Founder and secretary leading Italian aero clubs, etc.

CASTILLON DE SAINT-VICTOR (Comte G. de), 74 Avenue Marceau, Paris. Born 1870. Aeronaut since 1898. Did a trip, Paris to Sweden. Treasurer Ae. C. F., 1911.

CATERS (Baron de), Berchem-les-Anvers, Belgium. Born 1875. Motorist of renown in the early days. Early aviator pioneer.

CATTANEO. Italian. Well-known aviator since 1910.

CARDEN (Capt.). Experimental officer, appointed 1911, to British Army Air Battalion.

CAUMONT (*late* Lieut.). French aviator. Killed in a *Nieuport* monoplane, December 30th, 1910.

CAYLEY (George, Sir). Experimented about a hundred years ago with models and man-carrying gliders. Also wrote on Aviation, and is known as "the Father of Aviation."

CHANDLER (Capt. C. de F.) Commanding Signal Aviation School, U.S.A.

CHANUTE (Octave), U.S.A. Frequently alluded to as "the father of aviation." In company with Herring he joined Langley in 1905. He did much work with gliders. He propounded the theory that little was to be learned from studying birds. Discovered that the greatest lift was obtained from a plane flat in front and arched from the side. Died November, 1910. Aged 78.

CHATLEY (Professor H.), B.Sc, Imperial Eng. Col. Tientsin, China. Britisher. Author of *The Force of the Wind* (Griffin & Co.), and an authority on aviation matters in general.

CHAVEZ (Georges). Peruvian aviator, resident in France. Maker of many records. First aviator to fly the Alps, 22nd September, 1910. Fatally injured on that occasion.

CHEREAU. Frenchman. London manager of the Bleriot Co. and Bleriot School at Hendon.

CHOENDEL (*late*). German aviator, who made an altitude record of 1680 metres with a passenger. Killed on alighting.

CLEMENT (Gustave Adolphus), 33 Quai Michelet, Levallois-Perret (Seine), France. Born 1855. Officer Leg. d'Hon. Creator of the *Clement-Bayard* dirigibles, etc.

COCKBURN (Geo. B.), Gloucester, England. One of the first Englishmen to take up aviation.

CODY. American; naturalised British, 1909. Inventor of the Cody kite. Employed by the British War Office for aviation work, 1905-1909. Inventor of Cody biplanes. Won Michelin prize 1910 and 1911. One of the best-known British aviators. In August 1912, made a biplane speed record of 72.4 m.p.h. Constructor.

COLLOMB. Frenchman. Early experimenter with flappers, etc.

COLMORE (Cyril). British. Ae.C. Pilot 15. Flying partner with the late Cecil Grace. Now given up flying.

COLSMAN (Alfred), Friedrichshaven, Germany. Director of the Zeppelin Co., etc.

CONNEAU (Lieut.) French Navy. Winner of the *Daily Mail* £10,000 prize, 1911, with a *Bleriot*. Winner of the Paris to Rome and the Circuit of Europe races, 1911. Flies under the name of "Beaumont."

CORNU (Paul), 24 Rue de la Gare, Lisieux, France. Pioneer experimenter with helicopters. In 1908 one of his inventions rose 16 inches.

CROCCO (Lieut.) Italian. Had a good deal to do with the designing of the *Ricaldoni* dirigible.

CROOKSHANK (Major C. de W.), R.E. Prominent supporter of aviation. Member of the R. Ae. C. Committee, 1910-11.

CURTISS (Glen. H.), Hammondsport, N.Y., U.S.A. Won the Gordon Bennett in 1909 on the *Curtiss*. Formerly a member of the Aerial Experiment Association, out of which the *Curtiss* was evolved. Is Ae. C.F. Pilot 2. Head of the Curtiss Aeroplane Co.

DAHLBECK (Lieut.). First Swedish naval aviator. Trained in England.

DAVELNY. Commandant French Navy. Appointed 1911, to take command of French naval aviation.

DAUCOURT. Frenchman. First pilot to fly from Paris to Berlin, 16th April, 1913. Average speed 100 k.p.h. Time 12 hours, 32 minutes, including two stops.

DE BAEDAR (F.), 7 Rue Rameau, Paris. Editor *Revue Sportive de l'Aviation et de l'Automobile*.

DE DION (Marquis), 104 Avenue des Champs Elysées, Paris. Born 1856. Principal founder and Hon. President Ae. C. F.

DE HAVILAND (G.) British aviator. Designer of a biplane and a motor purchased by the War Office, in December, 1910. He was subsequently engaged by the Government for work on Salisbury Plain. In August, 1912, made the British altitude record to date of 9,500 feet with a passenger.

DELAGRANGE (the late Leon). Born 1872. French sculptor. Took up aviation early in 1907. He purchased *Voisin No. I*, which made its first trials 28th February, 1907. Subsequently engaged in experiments with Archdeacon. In 1908 bought a *Voisin No. III*. Later on got a *Bleriot*. Killed 4th January, 1910, at Croix d'Hins, Bordeaux, in a *Bleriot*. Was Ae. C. F. pilot 3.

DEMANEST (Rene). French. 25, rue d'Orleans, Neuilly sur Seine. Began flying an *Antoinette* in 1909. Won the Ae. C. F. prize.

DEPERDUSSIN. (See machines).

DEPREZ (Marcel). Frenchman. Writer on Aerial subjects.

DESBLEDS (L. Bein). Lecturer on Aeronautical Engineering, Polytechnic, London.

DEUTSCH (Henri de la Meurth), 4 Place des Etats-Unis, Paris. Officer Leg. d'Hon. Founder member of the Ae. C.F. Donor of the prize of 100,000 francs won by Santos Dumont, 19th October, 1901. Owner of the dirigible *Ville de Paris*. Vice-Pres. Legue Nat. Aérienne. Donor in part of the Deutsch Archdeacon prize. Offered 1909 to found a Technical Institute of Aviation, Paris University.

DICKSON (Captain). Ex-British Army officer. The first British aviator to distinguish himself at an International flying meet.

DOUTRE. French lawyer, interested in aviation. Invented a stabilising device in which Maurice Farman was interested.

DREXEL (A.) Scotland. American citizen. Made world's record at Lanark, 12th August, 1910, in a *Bleriot*, 6,750 feet (2,057 m.), beating previous record of Brookins.

DRIVER. British aviator. Flew in first aerial post, 1911.

DRZEWIECKI (Stefan), 62 Rue Boileau, Paris. Russian. Born 1844. Chev. Leg. d'Hon. In 1885 investigated aviation in connection with bird flight. Well known otherwise as an inventor of submarines, torpedo tubes, etc.

DU CROS (Harvey), M.P., 14 Regent Street, London, S.W. Born 1876. Takes considerable interest in aviation. Member of the Parliamentary Committee thereon.

DUFAUX (Armand). Swiss. He and his brother Henry were interested in aviation in 1903, and in 1904 built an helicopter. In 1909 the first Swiss aeroplane built by them appeared.

DUNNE (Lieut.), Eastchurch, Sheppey, Kent, England. Ex-British Army officer. Engaged by British War Office to carry out heavier than air experiments immediately after the aeroplane had been demonstrated a possibility. (See *Dunne* in part I.)

DUPUY DE LOME. Frenchman. Made a hand-propelled dirigible in 1870-72.

DÜRR (Ludwig). German. Born 1878. Chief engineer Zeppelin works.

DUTRIEU (Mdlle. Hélène). Belgian. Second woman to take up aviation.

EFIMOFF (Michael). Russian. Made his first appearance in France early in 1910. (Ae. C. F. pilot 31). Distinguished himself on *H. Farman's* and *Sommers*. On his return to Russia he was made chief instructor of the special school of the Volunteer Aerial Association.

ELLEHAMMER (J. C. H.), Istedgade 119, Copenhagen. Commenced aviation studies in 1905. On 12th Sept., 1906, he made a flight—the first in Europe since Ader.

ELLYSON (Lieut. T. G.) U.S. Navy. In company with Lieut. Towers made the first flights ever made in a hydro-aeroplane.

ELY (Eugene B.) American. Was the first to fly successfully off a warship, which he did in a *Curtiss* biplane on January 19th, 1911, from the U.S. cruiser *Pennsylvania*. Killed 1911.

ENGLEHARDT (Kapitan). Prominent figure in German aeronautical and aviation circles. Writer on aerial subjects. Began flying in 1910, in which year he won several prizes. Killed 1911.

EQUIVELLY (Marquis d'), 2 Place Wagram, Paris. Pioneer aviator, with a queer multiplane, 1907.

ERBSLOCH (the late Oscar). Well known aeronaut. Inventor of a German dirigible, the *R. M. W. G.*, afterwards named after him. He was killed in it with four others, July, 1910.

ESDAILE. British. Pioneered aviation displays in India, 1912.

ESNAULT-PELTERIE (Robert), 149 Rue de Silly, Billancourt (Seine), France. Early experimenter with aeroplanes. Flew the first *R.E.P.*, October, 1907. Designer of the *R.E.P.* engine.

ESPITALIER (Georges), 25 Rue St. Petersburg, Paris. Associated with the late Col. Renard in early dirigible experiments. Author of many aeronautical works.

ETRICH (Igo), Rotunde, Vienna II. Pioneer aviator with Wels. Designer of the *Etrich* monoplane—the first Austrian machine to fly.

EVANS (William Evans), 1428, Charlotte Street, Kansas City, Mo. Purchased a biplane built by Dr. William Greene, who has since given up aeroplane building. Evans made a number of exhibitions in the middle West, but had given up flying by summer of 1911.

EWEN (W. H.) British. Head of the School for British *Caudron*.

"F. A. I." Federation of the leading Aero Clubs of all countries, for control of International Aviation Meets, Pilot certificates, etc., etc. The bulk of certificates were first obtained in France, but in 1910 they were made obtainable in any country from its own Ae. C., under identical rules. No aviator may compete in any International event without a certificate. Aviation has now more or less outgrown the F.A.I., on account of the virtual disappearance of private aviation events before military interests; but it did excellent service in its time and is still of considerable indirect value.

FARMAN (Henri), 22 Avenue de la Grande Armée, Paris. Born in Paris, 1874, but is of English descent. Chev. Leg. d'Hon. First a racing cyclist, then racing motorist. Took up aviation. Bought *Voison No. II* (known as "*Farman I.*"). On January 13th, 1908, he won the Deutsch-Archdeacon prize for covering a triangular course of one kilometre. In 1909 designed and built his own machine. Won the Michelin cup in 1909, making the record of 4 h. 17 min. 35 2.5s. in the air. Ae. C. F. pilot 5. In 1910, did 8 h. 12 mins. in the air, covering 288¾ m. (463 km.)

FARMAN (Maurice), 3 Rue Villaret de Joyeuse, Paris. Brother of above. Went in for aeronautics and motor racing. Bought *Voisin No. IV* at an early stage of aviation. He fitted this with alterations of his own, and subsequently evolved the *M. Farman* biplane. Ae. C. F. pilot 6.

FAURE (Jacques), 32 Rue Washington, Paris. Born 1873. Has long been prominent in aeronautical circles. Has crossed the Channel five times in gas bag balloons. Owns the *Faure* dirigible. Member of Committee Ae. C. F.

FELIX (Capt.) In 1911 in charge of the Bleriot Military School at Etampes.

FERBER (the *late* Capitane), flew as "De Rue." Born 1862 at Lyon. Commenced experiments with gliders in 1899 on Lillieuthal lines. In 1903 he built a power-driven machine. He taught Gabriel Voisin how to fly gliders. In 1908 was very active and flew several machines. Killed in a *Voisin*, 22nd September, 1909.

FERNANDEZ (the *late*). A Spanish tailor, resident in Paris, killed in 1909 in a machine of his own design.

FISHER (E. U. B.) First flew on a *Hanriot*, early in 1911. August, 1911, engaged as pilot by Messrs. Vickers.

FOKKER (Antony), Haarlem, Holland. Born in Java, 1890. Designed a monoplane in 1911 with special stabilising device. He flew this at Johannisthal. Subsequently started a company.

FOURNY. French. On September 11th, 1912, broke all previous distance and duration records by flying, non-stop, 13 hours, 22 minutes in *M. Farman*. Renault motor. Distance 1,017 km. (631 miles) at Etampes, France.

FRISBIE (J. J.) American aviator. Killed in a *Curtiss* at Norton, Kan., having been driven to fly in unsuitable weather by the jeers of a hostile crowd.

FÜRSTENBERG (Prince). Austrian. President of the Centre Aeronautical Committee, formed in June, 1912.

GALANSCHIKOFF (Mdlle.) Russian. On November 22nd at Johannisthal, made world's altitude record for lady fliers with 2,400 meters.

GARROS. French aviator. Came in second in Paris to Rome and the Circuit of Europe races, 1911. Up to November, 1911, held world's height record (13,000 feet). Made in a *Bleriot*.

GASNIER (René), 1 Rue Scribe, Paris. Winner of many prizes in balloon events. French champion for the 1907 Gordon-Bennett. On Committee of Ae. C. F. Hon. President Ae. C. d' Ouest. Inventor of an aeroplane, 1908.

GAST (Madame C. Crespin du), 12 Rue Levoux, Paris. Well-known in aeronautical circles.

GASTAMBIDE (Robert), 27 Boulevard de Courcelles, Paris. Born 1882. Civil engineer. Took great interest in aviation at the start. Designed the *Gastambide-Mengin* from which *Antoinettes* were evolved. This was the first monoplane to carry a passenger (September, 1908.)

GELEYNS (C.) Editor of the *Avia*, Wynbrugstreet 13, Rotterdam.

GERRARD (Lieut.), R.M.L.I. British. August 17th, 1911, made world's passenger record to date, 4 hours, 13 minutes, on *Short No. 34*.

GIFFARD (H.) Britisher, resident in France. In 1850 built the first practical dirigible. It had a steam motor. In 1852 it made a controlled speed of about 5 m.p.h.

GILBERT. French. On March 28th, 1913, flew from Lyons to Villacoublay in 3 hours, 10 minutes, a world's record to date from town to town non-stop.

GILL (Howard). U.S.A. aviator. In October, 1911, flew for 4 hours 16 minutes 35 seconds in a *Wright*. American record to that date.

GILMOUR (Graham). British. Pilot Ae. C.F., April, 1910. In 1911, flying a *Bristol*: with which many of his flights have been directly or indirectly of a highly sensational nature. These have included a flight alleged to be over London (reported to R. Ae. C.—case dismissed), flying low over Henley Regatta (certificate suspended, with subsequent litigation). Won second prize in the Brooklands-Brighton Race, May, 1911. Killed February, 1912.

GIBERT. French aviator who made records, 1911.

GLAZEBROOK (Dr. R. T.), C.B., F.R.S. Director of the British National Physical Laboratory.

GLIDDEN (Charles J.) The well-known American motorist. Founder of many of the U.S.A. Ae. clubs.

GODARD (Louis), 170 Rue Legendre, Paris. Builder of the *America* Wellman Arctic Airship; inventor of the Godard Kite-Balloon; designer and builder of the *La Belgique*, etc., etc.

GORDON-BENNETT (James), 104 Avenue des Champs Elysees, Paris. American citizen. Owner of the *New York Herald*. Giver of the Gordon-Bennet aviation Prize. Previous to this he had instituted a similar event for motor cars, and few, if any, have done so much to advance the International sporting side of automobilism.

GOUPY (Ambrose), 59 Avenue Marceau, Paris. An early pioneer in aviation experiments—had the first triplane built for him by *Voisins*. Now a well known constructor.

GRACE (*late* Cecil). Naturalised British subject, ex-Chilian. Lost at sea while competing for the Baron de Forest prize, December, 1910.

GRADE (H.), Magdeburg, Germany. First man to fly in Germany. He did this on a Grade triplane early in 1909. Now a well known German constructor.

GRAHAME-WHITE (Claude), 1 Albemarle Street, Piccadilly, London. Pilot 30 Ae. C. F. on a *H. Farman*. Attempted to win the *Daily Mail* £10,000 London-Manchester prize, 1910. Gordon Bennett, 1911. Now constructor.

GREENE (Dr. W.), Treasurer, Aeronautic Society, U.S.A. Has done a great deal to advance aviation in the U.S.A. Designer of the *Greene* biplane—a machine which in no way infringed the Wright patents.

GRESWELL. British aviator. Flew in first aerial post, 1911.

GREY (Chas. G.), 166 Piccadilly, London, W. Editor of the *Aeroplane*. Well-known writer on aerial matters, formerly as "Aero-Amateur," later under his own name. By 1912, had come to occupy a unique position of his own by an uncompromising statement of facts without regard to other circumstances.

GROSS (Major). In command of the German war dirigibles. Designer of the *M* type. (*Gross*).

GRUBB (Capt. A. H. W.) D.S.O., R.E. Prominent supporter of aviation. Member of R. Ae. C. Committee, 1910-11.



GUILLEMEAU (R.), 82 Rue d'Amsterdam, Paris. Editor *Revue Francaise, de Const. Autble et Aeronautique*.

HAENLEIN (Paul). German, 1835-1905. Early experimenter with dirigibles. Inventor of the "semi-rigid" system.

HAMEL (Gustav). British. Well-known aviator. Winner of Brooklands-Brighton Race, May, 1911. Flew the first British aerial mail, 1911. In April, 1913, on behalf of the *London Standard*, made a non-stop flight with a passenger London to Cologne in a *Bleriot*. Many other famous flights.

HAMMOND (J. J.) Australian. Pilot 258, Ae. C. F., on a *Sanchis Besa*, 4th October, 1910. In 1911, visited Australia with a *Bristol*, when he made many sensational flights.

HARGRAVE (Lawrence), Sydney, N.S.W., Australia. A pioneer in aviation, 1890-95. Experimenter with and inventor of box kites.

HARKNESS (Harry). American aviator. Has made various records.

HARMON, (Clifford B.) One of the best-known U.S.A. amateur aviators. Made U.S.A. time record (2h. 3m.), 2nd July, 1910.

HARRISON (Eric). Australian subject. Instructor of the Bristol school at Lark Hill, Salisbury Plain, 1912.

HARRISON (Lieut. L. C. R.) British R. F. C. Killed 28th April, 1913, in the famous *Cody* which won the British Military Aeroplane competition.

HAULT (Adhemar de la), 214 Rue Royale, Brussels. Editor of *La Conquête de l'air*. Well-known aviation pioneer. Interested in Ornithopters.

HAWKER (H. G.) Australian subject. On October 24th made British duration record to date—8 hours 23 mins. in *Sopwith* biplane. Awarded the Michelin Cup, 1912.

HEKING (R.) Frenchman. In September, 1909, carried out experiments with a biplane glider of 7 m. span and 25 m<sup>2</sup>. surface. He rose to a height of 25 m., and is stated to have remained stationary for 5 minutes. Not confirmed, however.

HELEN. French aviator. Has appeared in various competitions since early in 1911.

HENDERSON (Brig. Gen.) British Army. First general to obtain British R. Ae. C. aviator certificate. Flying under the name of "Davidson" he obtained his certificate on a *Bristol*, at Brooklands, after seven days' training.

HENRY, Prince of Prussia. Well known for practical interest in motoring and aviation. Has driven his own car in races, and is a certificated aerial pilot for Germany.

HENSON. Died 1842. Projected a steam-driven monoplane early in the XIX century.

HERRING (A. M.), Freeport, Long Island, U.S.A. Started the study of aviation 1894. With Langley, 1895. With Chanute, 1896. Joined Ae. Exp. Assoc. and associated with Curtiss in the *Herring-Curtiss*. Subsequently (1910) with Burgess in the *Herring-Burgess*.

HERVE (Henri), 1 Rue Hautefeuille, Paris. Well-known authority on matters aeronautical. Author, etc.

HEWLETT (Mrs. Maurice) ("Madame Franck"). First lady aviator to obtain a British R. Ae. C. certificate.

HILDEBRAND (Kapitan Alfred), 10 Martin-Lutherstrasse, Berlin W. 30. Retired from German Army. A very well-known aeronaut. Owner of a Baldwin dirigible. Author of many works on aeronautics and aviation—the best known German writer on these subjects.

HINTERSTOISSER (Hauptmann Franz), Luisenstrasse 35, Vienna V. Commanding Austro-Hungarian Aeronautical service. 1911-12.

HIRTH (Helmuth). German. Made German passenger altitude record to date, at Johannistal, September-October, 1911. Height 2475 metres. Many other records. The best known of all German aviators.

HOFFMAN (Joseph). German. Built a steam-driven aeroplane in 1906.

HOLDEN (Col. H. C. L.) R.A.F.R.S. Prominent supporter of aviation. Member of the R. Ae. C. Committee, 1910-11.

HOWARD-FLANDERS. See British Aeroplanes, Part A.

HOWARD-WRIGHT. British. Early designer (see Part B). In January, 1913, became manager of S. White & Co., of Cowes.

HOUDINI (Harry). British. The famous "Handcuff King" flew a *Voisin* so long ago as November 2nd, 1909. He took it to Australia and won the first aeroplane flight prize there. He is the first to have taken out a "third party" insurance, which he did with the Albingia-Versicherungs-Aktien-gesellschaft, Hamburg, Germany, on November 29th, 1909. The policy was for 150,000 marks.

HUBERT. French aviator. Flew in the first British aerial post and was badly injured.

HUCKS (B. B.) British aviator. Has made several fine exhibition flights on a *Blackburn*. First man to make the double journey across the Bristol Channel, also to carry out wireless telephone experiments with aeroplane.

HUNTINGDON (Prof. A. K.), 14 Buckingham St., Charing Cross, London, W.C. Born 1856. Balloon expert, 1906-1908. Connected with the *Dunne* machines. Member of the R. Ae. C. Committee, 1910-11.

HURLBERT (Dr. Dane), Vermont, Lucerne, Switzerland. U.S.A. citizen. Experimenter in original types of aeroplanes, 1909-11

ILLNER. First man to fly in Austria, which he did on an *Etrich*.

ISSATIER. French private soldier who obtained three weeks' leave and secured his flying certificate at Betheny after fourteen days, in a *Deperdussin*.

ISENDAHL (Walther). German. Holsteinstrasse 21, Berlin-Wilmersdorf. Leading authority on aerial and boat motors.

JANE (Fred T.), The Hill, Bedhampton, Hants, England. Naval author, founder and editor of *All the World's Air-craft*.

JANNUS (Antony). American. Well-known aviator.

JATHO (Karl), Stader Chausse 22, Hanover, Germany. Born 1873. Pioneer aviator from 1893. Has built various machines—none very satisfactory.

JEANNIN (Emil), Berlin. Prominent German aviator.

JEFFERIES (Dr. John). 1760-1820 *about*. American. Accompanied Blanchard in the first balloon voyage across the English Channel, 1784.

JENKINS (F. Conway). In May, 1911, obtained his certificate (74) after only four flights on a *Roe* biplane.

JOHNSTONE (St. Croix). American aviator. 27th July, 1911, beat American duration records in a flight of 4 hours, 1 minute, 54 seconds. Distance 176 miles. Killed 1911.

JONES (Ernest L.), 250 West 54 Street, New York. Editor of *Aeronautics* (U.S.A.)

JOSEF FERDINAND (Grand Duke of Austria). Enthusiastic aeronaut and moving spirit in aviatory matters in Austria.

JOYNSON-HICKS. British M.P. who has specialised in endeavouring to advance aviation.

JULLIOT (Henri), 3 Rue de Flandre, Paris. Born 1855. Chev. Leg. d'Hon. Technical director of the *Lebaudy* works. Originator of the *Lebaudy* type of dirigibles. Designer of *Lebaudy* aeroplane. Member of Committee Ae. C. F.

KAPFERER (Henry), 26 Rue de Clichy, Paris. Chev. Leg. d'Hon. Director of the *Astra* Cie, and the Cie Gen. Transaerienne. Part designer of the Clement-Bayard dirigibles. Took an early interest in the aeroplane movement, and had a biplane built to his own design by Voisins in 1907. Also had an early monoplane about the same date or a little later. On Committee Ae. C. F.

KASSNER (Carl), Wilhelmstr. 10, Berlin. Professor, German writer on technical aviation matters.

KENNEDY (Rankin), British authority on aviation subjects.

KENNEDY. St. Petersburg. British subject. Engineer who has studied aviation for many years. In 1911, was an honorary aerial adviser to the Russian Government on matters aerial.

KINDELAN (Captain), Guadalajara, Spain. Born 1879. Interested in balloons since 1906. Designer of the Spanish military airship *Torres Quevedos*.

KNIGHT. British. Instructor 1912, Vickers School.

KOENIG. German aviator. Won the 1st prize given by the Berliner *Zeitung am Mittag*. 1,182½ kilos.

KRAUSS. Well-known German aviation engineer. Author of many articles.

KRESS (Wilhelm), Waaggasse 13, Vienna. Born 1836. Flew a model ornithopter in 1888. Author.

KRIEGER (Hans). German. Formerly chauffeur to the Kaiser. Built a monoplane of his own design, and on September 5th, 1911, obtained his certificate on it.

LAFFONT (*late* A.) Killed in an *Antoinette*, December 28th, 1910.

LAHM (Frank), Washington D.C., U.S.A. Well-known aeronaut.

LAMBERT (Albert B.) President of Ae. C. of St. Louis, U.S.A. Flies a *Wright*.

LAMBERT (Count Charles), 74 Rue Charles-Lafitte, Neuilly-sur-seine, Paris. Russian subject. Born 1865. Interested in aviation 1893 onward. First pupil of Wilbur Wright.

LAMMLIN. German. Killed at Strasburg, May 23rd, 1911.

LANA (Francisco), (1631-1687), (Italian). Jesuit who projected flying machines.

LANCHESTER. Author of well-known aerial classic.

LANE (Howard), 50, Parliament Street, Westminster, London, S.W. British citizen. Mechanical and Chemical Engineer. Born 1852 at Warwick. Government Contractor; Birmingham City Councillor, 1895-1900. Honours, South Kensington, 1873. Inventions, the Seamless Steel Gas Cylinder, 1882; Multiple Stage Gas Compressor, 1884; Roller method of Skin Balloon Construction, 1887; Regenerative Hydrogen Producing Plant, 1903; Turbine Aero-Motor, 1909, etc., etc.

LANGLEY (Samuel Pierpont). Born 1834. Died 1906. American pioneer from 1887. Commenced work in 1893 with Dr. Graham Bell, and later, Herring and Chanute. In May, 1896, he flew a large steam-driven model tandem monoplane—the *Langley* type. Author of *Experiments in Aero Dynamics* and other aerial classics.

LANZ (Karl), Lachnerstrasse 18, Mannheim, Germany. Wealthy patron of aviation in Germany. Giver of the £2000 Lanz prize won by Grade. Financed the *Schütte* dirigible.

LAROCHE (Madame la Baronne Raymonde de). The first lady aviator. Pilot Ae. C. F. 36. Purchased a *Voisin* in the summer of 1909 and entered for International events. Badly injured in an accident at Reims, July, 1910. In 1913, took up flying again.

LATHAM (Hubert), 7 Rue Rembrandt, Paris. Of English descent one side. Pilot 9 Ae. C. F. Director of the *Antoinette Cie*. Attempted to fly the Channel, 1909. (1) in *Antoinette IV*. (2) in *Antoinette VII*. (3) in August, 1910. Maker of many records. Killed by a buffalo, 1912.

LA VAULX (Comte Henri de), 2 Rue Gaston de St. Paul, Paris. Born 1870. Chev. Leg. d'Hon. Vice-President Ae. C. F., and one of its promoters. Founder and Vice-Pres. of the F.A.I. Took up aeronautics in 1900, since when he had made over 250 ascents. Record holder for "gas bags." Owner of a *Zodiac* dirigible in 1909-10.

LEBAUDY (Robert), 12 Rue de Lubeck, Paris. Sugar refiner. Member Ae. C. F. Founder of the *Lebaudy Dirigible Cie*.

LE BLANC (Alfred), 17 Rue Lakanal, Paris. Born 1869. Aeronaut in 1904. Winner of the *Circuit d'Est*, Aug., 1910.

LE BLON (*late*). Frenchman. Born 1875. Killed in a *Bleriot* at S. Sebastien, 2nd April, 1910.

LEFÈBVRE (Eugene). French aviator. Killed on a *Wright*, 7th September, 1909, at Juvissey.

LEGAGNEUX. In December, 1910, made a flight of nearly 6 hours, at Pau, (322 mile—53 m.p.h.) average, in a *Bleriot*.

LESSEPS (Comte Jacques de), 11 Avenue Montaigne, Paris. Well-known aviator in the early days.

LEVAVASSEUR. Known in France as "Père Levavasseur." Chief engineer of the Antoinette Works and *deus ex machina* of the type. He severed his connection early in 1910, but rejoined in June, 1910, and remained as long as the company existed.

LEVE (Pierre), 17 Rue Cassette, Paris. Editor of *La Revue Aérienne*, official organ of *La Ligue Nat. Aérienne*.

LILIEUTHAL (Gustav), 5 Marthastrasse, Gross-Lichterfelde, Germany. Brother of the late Otto Lilieuthal, whose work he has carried on. Author.

LILIEUTHAL (Otto, the *late*). German subject. Began his interest in aviation when 15 years old. In 1889 published his *Bird Flight as a Basis of the Flying Art*, the result of 25 years observation of sea-gulls and storks. In 1891 he made glider flights. In 1895 he produced a biplane glider. On 12th Aug., 1896, he was killed while experimenting. Lilieuthal was the fountain head of modern aviation.

LINKE (Dr. Franz), Kettenhofweg 181, Frankfurt, Germany, Scientist. Born 1878. Author of *Moderne Luftschiffahrt* and other works.

LIORE (F.), 4 bis Rue de Corneille, Levallois-Perret, France. Early pioneer with the *Witzig-Liore-Duthileuil*. Since then evolved a monoplane.

LÔME (Dupuy de). See DUPUY DE LÔME.

LORIDAN. In July, 1910, in a *H. Farman* racer broke the existing altitude record by making 3,280 m. (10,758ft). Did 702 km., July, 1911.

MALONE (Lieut. Cecil J. L'Estrange). R.N. Navy Wing of British R. F. C. Assistant to director of Flying at Admiralty, end of 1912.

MAHIEU. In September, 1911, made the world's passenger record of 2460 metres (7981 feet) in a *Voisin*, at Issy. Duration of flight 3½ hours.

MANNING (H.) British. Aeroplane designer.

MAREY (Professor). Inventor of the Whirling table, 1870.

MARIE (Capitaine). French Army. On staff of Inspector General of Aeronautics.

MARIE (Pierre). Alsatian. Real name was Bournique. He made his name on a *R.E.P.'s*. In May, 1911, he was trying a 100 h.p. *Deperdussin* when the machine capsized and fell. He was taken to hospital and died a few hours later. His passenger, Lieut. Dupuis, was burned to death.

MARS ("Bud"). Well-known American aviator. Has more than once been reported killed; but always appears again.

MARTIN (Glen L.) Santa Ana, California, U.S.A. Flying *Curtiss* types. Obtained a considerable reputation, and local amateur record at Los Angeles meet, end of 1910.

MASSAC BUIST. (See BUIST).

MATSIEVITCH (Kapitan). Russian Army. Was Instructor of the Military Aviation School at Sevastopol. Killed at Sevastopol, 1911.

MAXIM (Sir Hiram), Baldwyn's Park, Kent. Inventor of the Maxim gun, etc. American by birth, naturalised British subject. Began experiments with propellers, etc., in 1889. In 1890 to

1893 he experimented with a full-sized aeroplane, steam propelled. Abandoned the experiments after spending £20,000 on them. Resumed work 1909, without success. Author of *Artificial and Natural Flight*.

McCLEAN. British aviator. Towards the end of 1910, he loaned two *Short* biplanes to Eastchurch flying ground for the training of naval officer in aviation, and himself acted as instructor. These were the first machines used by the British naval officers, consequently Mr. McClean may be regarded as the founder of the British Naval Aeroplane Division. Member of the R. Ae. C. Committee.

MENGIN (L.), 2 Rue Debrousse, Paris. Born 1881. Early experimenter. Flew in 1908 in the *Gastambide-Mengin*, from which the *Antoinette* was evolved. Director of the late *Antoinette Cie*.

MERRIMAN. British. Expert Bristol flyer at Brooklands, etc., 1912. Instructor.

MESSNER (Haupt. E.), Claridenstr. 36, Zurich. In command Swiss military aviation section, 1911-12.

MICHELIN (A. J.), 105 Boulevard Perière, Paris. Born 1853. Chev. Leg. d'Hon. Director of the well-known tyre manufacturers. Donor of the Michelin prize for aviation. Founder member Ae. C. F.

MOEDEBECK (Hermann W. L.) Born 1857. Died 1910. German author on aerial matters.

MOEDEBECK (Lieut. Col.). German subject. Author of *Fliegen de Menschen* (Salle), a very useful work on aviation. Also of a *Pocket Book of Aeronautics*, etc.

MOINEAU. Frenchman. In August, 1911, with two passengers made a record on a *Breguet*, of reaching 900 metres in twenty minutes at Douai.

MOISANT (Miss Matilda). Sister of the late J. M. Moisant. Second American lady to obtain certificate. Used a *Moisant*.

MOISANT (John). Architect. American citizen, resident in Paris. Invented two monoplanes. In Aug., 1910, flew the Channel with a passenger in a *Bleriot*. This was the first cross-Channel passenger trip. Killed 1911.

MONTAGU (Lord), of Beaulieu. Editor of *The Car Illustrated*. Prominent in arousing British interest in aviation.

MONTGOLFIER (Joseph Michael and Jacques Etienne). Frenchmen, who about the year 1780 invented hot air balloons. In 1783, one such, of 35 feet diameter, rose to a height of about 1,500 feet.

MONTGOMERY (John Professor), U.S.A. citizen. Began experiments with gliders in 1884, which he continued till his death by accident with one, on 31st October, 1911, at Evergreen, Santa Clare, California.

MOORE BRABAZON (J. T. C.), 29 Chesham St., London, S.W. Born 1884. Originally sporting motorist; winner Circuit des Ardennes, 1907. Took up aviation at an early stage. Bought an early *Voisin* which he named *Bird of Passage*. This machine was later sold to A. George, who had a smash in it, and sold it later to Grace. Moore Brabazon was the first Britisher to fly. Pilot I, R. Ae C.

MOORHOUSE (W. B. R.), Portholme Aerodrome, Huntingdon. British. Has done a good deal of cross country flying, 1911. Part inventor of the *Radley-Moorhouse* (R. M.) monoplane, 1911.

MORANE (Leon). Frenchman. Well-known *Bleriot* pilot. Subsequently built the *Morane* monoplane. Very badly injured in an accident, Autumn, 1910.

MOREAU. French amateur. Inventor of a special stabilised aeroplane.

MORIS (Colonel). Commanding Italian air battalion, 1911-13.

NEMETHY (Emil), Arad, Hungary. Born 1867. Built his first effort, a helicopter, in 1899. Has experimented ever since, but without much success. Inventor of the *Aviette*.

NEUMANN. Germany. Author of various very reliable works on dirigibles.

NICKEL (Hugo Ludwig), Kahlenbergerstrasse 97, Vienna. Born 1867. Aerial author and journalist.

NIMFÜHR (Dr. Raimund), Lerchengasse 15, Vienna. Born 1874. Experimentalist 1900 onward. Author.

NORTHCLIFFE (Alfred Charles Harmsworth) Lord. British subject. Founder and proprietor of the "Daily Mail." Donor of many important aviation prizes, including the £10,000 London-to-Manchester prize.

OERTZ (Max), Holzdamm 40, Hamburg, Germany. Interested in gliders. Connected with German North Pole Dirigible Expedition. Designer of various aeroplanes.

OGILVIE (A.) Represented Great Britain in both the 1910 and 1911 Gordon Bennetts. Took fourth place in 1911. Average speed, 51 miles per hour. Flew a *Wright*. In December, 1910, flew for nearly 4 hours on a *Wright* over the Camber sands; distance being 139¾ miles. Associated with the Wright Brothers experiments at Kitty Hawk, October, 1911.

O'GORMAN (Mervyn). Well-known authority on aviation matters, and Superintendent of the Royal Aircraft Factory.

OSMONT. Frenchman. Formerly racing cyclist. Did some fine flights at Chalons in 1910. In February, 1911, appointed chief aviation instructor to the Spanish Army.

OTTO (Fried), Hohenstaufurstrasse 35, Berlin. W. 30. Aerial journalist, etc.

OVINGTON (Earle). U.S.A. aviator. Carried first U.S.A. aerial post, Sept 1911. Winner of many prizes in America.

OXLEY. Instructor to the Blackburn School, at Filey, 1911.

PAINE (Capt. G. M.) M.V.O., R.N. Commandant of the British Central Flying School at Upavon, Salisbury Plain. Appointed early in 1912.

PARKE (Lieut. Wilfred, R. N.) Started flying in 1910, and made a large number of meritorious performances. Killed in a monoplane at Wembley, December 15th, 1912.

PARSEVAL (Major Von), late German Army. Inventor of the *Parseval* type dirigibles and the *Parseval* monoplane. Leading figure in all aerial matters in Germany. (See Part A.)

PATERSON (Compton). British aviator. Liverpool Motor House, Ltd., Liverpool. Designed a successful machine in 1909. Also flies *Farmans*. Designed new machine 1911.

PATIALA (Maharajah of). In December, 1910, purchased a *Bleriot* and a *Voisin*. Member of the R. Ae. C.

PAGNY. French. Designer of *Hanriots*, 1913.

PAULHAN (Louis). Frenchman. Born 1883. Served afloat as a boy. Later served with the late Col. Renard; also with the late Captain Ferber. In 1907 was with Surcouf. In his spare time he made models. In 1909 he won a *Voisin* biplane, given as prize for the best model in France, and rapidly came to the front. In 1910 he won the *Daily Mail* £10,000 prize for the London to Manchester flight. Numerous other prizes have been won by him. Took up construction in 1911 without much success till in 1912 he took over French, etc., agency for *Curtiss* hydros.

PEQUET (H.) Frenchman. Certificated June, 1910. Flew a *Humber-Sommer* in India, where he conveyed the first officially recognised aerial post at Allahabad.

PERRIN (H.) British. Secretary of the R. Aero Club.

PERRY (Ida), Metropol Theater, Berlin. German actress, who has gone in for aviation.

PFITZNER (*late* Lieut. Alexander L.) Hungarian. Born 1875. Served in the Austro-Hungarian Artillery. Leaving the Army he went to the U.S.A. and became connected with the Herring-Curtiss work, designing the novel Pfitzner monoplane. He met many mishaps with this, which depressed him. He returned to Hungary early in 1910, but meeting no success there came back to America. Drowned in Marblehead Harbour, 12th July, 1910.

PHILLIPS (Horatio F.), Wealdstone, Harrow. Pioneer experimenter. Discoverer of the "dipping front edge," patented by him 1884 and 1891. ("Philips' entry.") Leading authority on aviation subjects.

PICKLES (Sydney). Australian. Chief pilot at the Ewen school at Hendon, 1912.

PICHAN (Court). Early French experimenter. Flew a flapper model 1889.

PICOLLO (*late* Jules). Brazilian aviator. Killed December 28th, 1910.

PIERRE (Petit). Frenchman. The *late* secretary of Bleriot School at Hendon. Assassinated at Hendon, August, 1911, by a Swiss pupil named Hanot, who went insane at not learning to fly so quickly as he had expected.

PILCHER (*late* Percy S.) Born 1866. British naval engineer. Commenced glider experiments, 1895, on Lillieuthal lines. Designed a power machine in 1899, but was killed in glider experiments before it was completed.

PIXTON (H.) British R. Ae. C. pilot 50. Qualified at Brooklands, January, 1911, on a triplane. Has since done some very fine flights on an *Avro*, taking various prizes.

PISCHOFF (Alfred de), 12 Rue Amiral de Joinville, Paris. In conjunction with Koechlin was a pioneer of French aviation. In December, 1907, he flew a kilometre on a biplane. His earliest machine was practically a large box kite with a motor fitted. In 1910 produced a monoplane of his own design. He is an Austrian resident in France.

POPPER (Josef). Austrian. Concerned with aviation, etc., ever since 1872.

POLLOCK (C. F.) Prominent supporter of aviation. Member of the R. Ae. C. Committee, 1910-11.

PONNIER. Frenchman. Director of the Hanriot Company.

PRANDTL (Dr. Ludwig). Prinz Albertstrasse 20, Göttinger, Germany. Born 1875. Leading figure in German aerial circles. Connected with the *Parseval* design.

PREVOST (M.) French. Created world's record on December 2nd, 1911, by reaching a height of 9,800 feet at Rheims.

PRIER (Pierre). Made London-Paris in 3 hours, 56 minutes, 12th April, 1911. Designer to the *Bristol Co.*, 1911.

QUEROZ (*the late*). Brazilian. Killed at S. Paulo, June, 1911, in a monoplane of his own design.

QUIMBY (Miss Harriet). Mineola, U.S.A. First American lady to qualify for aviator certificate, 1st August, 1911. Used a *Moisant*. Killed 1912.

QUOIKKA (Haupt. Emanuel), Margarethenstrasse 16, Vienna. Aeronaut from 1904. Now aviator and writer on subject.

RADLEY (James). Well-known British aviator, flying a *Bleriot*. Patented a special wing. Represented Great Britain in the 1910 Gordon Bennett. At Lanark, 1910, broke the world's then

speed record, and did 75 miles per hour. Pilot R. Ae. C. 12, June 14th, 1910. August, 1911, flew the Channel in 22 minutes; Calais to Folkestone. Subsequently embarked on construction.

RAYNHAM (F. R.) British subject. Flew 7 hours, 30 mins. competing for the Michelin Cup. Used an *Avro* fitted with a 60 horse Green.

REISSNER (Dr. Ing. Hans), Lutticherstrasse 166, Aachen. Born 1874. Professor on matters aerial.

RELTICH. French. Cyclist who succeeded in getting an avietter to fly one metre, October, 1912. Won the Dubos prize.

RENARD (*late* Colonel). In association with Krebs built a dirigible in 1884, with electric motor. Killed.

RENARD (Commandant Paul), 41 Rue Madame, Paris. Born 1854. Officer Leg. d'Hon. Brother of late Col. Renard, with whom he worked. Vice-President, *Ligue Nat. Aérienne*. Professor *Ecole Sup. d'Aéronautique*. Has written a good deal on aerial subjects.

RENAUX. Did 12 hours 12 minutes on a *M. Farman*, 7th August, 1911. (690 k.m.) Won the Quentin Bauchart Prize, 1911.

RENAUX. French aviator. Winner of the Grand Prix Michelin, March, 1911, Paris, to top of the Puy de Dome. Machine, *Maurice Farman*.

RICHET. French patron of early aviation experiments, 1896. Tatin built a large model machine for him in those days, which after a 150 yard flight fell into the sea and was lost.

RIDGE (Theodore). Assistant Superintendent of the Army Aircraft Factory. Killed on August 21st, 1911.

ROBINSON (Hugh). Well-known U.S.A. aviator.

ROBL (*late* Thaddeus). German aviator. Killed on a *Farman*, 1910, through attempting to fly in unpropitious weather in order to allay the complaints of sightseers. Has been designated the "first martyr of aviation"—not without some cause.

RODGERS (C. P.) U.S.A. aviator. *Wright*. In September-October, 1911, he flew across America, distance 4,321 miles. He started to win the Hirst prize of £10,000, but having taken longer than 30 days was disqualified.

ROE (A. V.) Clifton St., Miles Platting, Manchester. Was the first man to fly in England, and also the first to fly an all-British machine. Is a persistent experimenter on original lines. Has flown with as little as 9 h.p. in one of his triplanes. Now builds mono. and biplanes (*Avro*).

ROEHRIG (B. F.) U.S.A. aviator. Obtained wide reputation with *Curtiss* types on Pacific Coast.

ROGER, 8 Rue Grange-Batelière, Paris. Founder and editor of *Revue de l'Aviation*.

ROGUES (General). French Army. Inspector General Military Aeronautics, 1911.

ROLLS (*late* Hon. C.) Well-known British sportsman, motorist, and aviator. First Englishman to order an aeroplane—a *Wright*. Flew the Channel both ways early in 1910 (first record). Killed at Bournemouth, July, 1910, in a *Wright*.

RUCK (Major-General), C.B., R.E. Chairman of the Aeronautical Society of Great Britain.

RUSSIJAN. Austrian aviator. Killed January 9th, 1911.

SALMET (Henri). French. Born 1878. Made British height record, 8,070 feet, November, 1911. Made record London-Paris flight, March, 1912. Time: 3 hours, 14 minutes.

SAMPSON (Lieut.) British Navy. On August 17th, 1911, made British flight duration record to date, 4 hours 58½ minutes, at Eastchurch on a *Short 38*. Now Acting-Commander. Employed by Naval Wing, R.F.C.

SAMUELSON (Arnold), Hamburg Waterworks, Germany. Born 1837. Writer on aerial matters.

SANTOS-DUMONT (Alberto), 150 Avenue des Champs-Elysees, Paris. Brazilian, of French descent. Born 1873. Officer Leg. d'Hon. Took up ballooning at an early age. He was the first to use a petrol motor in a balloon. In 1900 the fifth dirigible constructed by him crossed the Seine. On Oct. 19th, 1901, in No. 6, he circled the Eiffel Tower and won the 100,000 franc Deutsch prize. In 1906 he became interested in heavier than air machines, and began on a helicopter. Abandoning this he built a box kite type of aeroplane, and on October 23rd, 1906, won the Archdeacon prize for a heavier than air flight of not less than 25 metres. Thereafter, comparatively little was heard of him, except that he was experimenting with the *Demoiselle*, till in 1909 he made a record on this type—the designs of which he presented to the world. Has not been prominent since.

SCHABSKY (Athanasius Ivanovitch). Russian. Builder of the *Outchebny* type dirigible.

SCHIERE, J. Aeronautical engineer. Stephonsonstraat 41, The Hague, Holland. Librarian Dutch Ae. C.

SCHÜTTE (Prof. Johann), Jäschkenthal 47b, Danzig-Langfuhr, Danzig, Germany. Born 1873. Designer of the *Schütte* dirigible.

SCHWANN (Commander Oliver). British Navy. Navy Air Dept., 1912-13. In 1911, conducted a number of hydro-aeroplane experiments.

SCRAGG (Geo. H.), American citizen, 19-21, Great Queen Street, Kingsway, London, W.C. European correspondent of American *Aeronautics*.

SELLERS (M.B.) (See U.S. aeroplanes)

SELLS (Chas. de Grave), La Colombara, Cornigliano-Ligure, Italy. British. A leading authority on all matters having to do with engineering. Also a writer on these subjects. Authority on matters having to do with aviation in Italy.

SHAFFER (Cleve T.) American citizen. West Coast correspondent to *Aeronautics* (U.S.A.) Writer on aerial subjects generally.

SIMON (Rene). August 18th, 1911, tied with Sopwith for the world's Climbing speed at Chicago; 500 metres in 3' 35".

SMITH (H. White). British. Secretary to the Bristol Co.

SOMMER (Roger) Mouzon, Ardennes, France. Born 1877. Early interested in aviation. In 1908 built a machine of his own design. This was a failure. He then bought one of the first *Farman's*, on which he rapidly achieved success. Towards the end of 1909 he produced the *Sommer* biplane.

SOPWITH (T.) British. Won the Baron de Forest prize on a *Howard Wright*, 1910. Also won many other prizes in England and America. 19th August, 1911, tied with Simon, world's climbing speed—500 metres in 3' 35"—at Chicago. Now a constructor.

SPENCER (Stanley). Early British dirigible builder (1902). Died 1913.

SPOONER (Stanley), 41 St. Martin's Lane, W.C. Editor of *Flight*. Prominent supporter of aviation. Member of R. Ae. C. Committee.

STEIN (Lieut.) German aviator. Killed at Doerlitz, February 6th, 1911.

STRINGFELLOW. British. A very early experimenter. In 1868 he evolved a triplane model.

SUETER (Capt. R. N.) British. In command of British Navy dirigible section, 1911. Admiralty Air Dept., 1912-13.

SURCOUF (Edward Louis), 33 Boulevard Lannes, Paris. Born 1862. Chev. Leg. d'Hon. Secretary Com. Sport Ae. C. F. Sec. Com. Aerienne Mixte. Director of the *Astra* Société. Constructor of the majority of French dirigibles.

SWANN (Rev. Sydney), The Vicarage, Crosby Ravensworth, Westmoreland, England. First clerical aviator. Ceased.

SYKES (Major F. H.) Officer Commandant in Charge of Records, Royal Flying Corps, Military Wing.

TABUTEAU. French aviator. Winner of the Michelin Trophy.

TADDEOLI. Swiss. First Swiss to obtain an aviator's certificate, which he did on a *Dufaux*, October, 1910. Badly injured at Lausanne, June, 1911, during exhibition flights. 1912, built a hydro-aeroplane.

TATIN (Victor), 14 Rue de la Folie-Reynault, Paris. Chev. Leg. d'Hon. Born 1843. Commenced heavier than air experiments so long ago as 1879, when he made an aeroplane driven by compressed air. Designed the *Ville de Paris*. Had a good deal to do with the *Bleriot* in its early days. In 1909 designed the *Clement-Bayard* monoplane. Associated with Paulhan in 1911. Writes on all aerial subjects.

TAYLOR (Vincent P.) Australian subject. Well-known aeronaut, using the *nom de plume* of Capt. Penfold. In 1912 went in for aeroplaning, using a *Bristol*.

TISSANDIER (Gaston). French Pioneer aeronaut. Made an electrically-propelled dirigible in 1881. Born 1843. Died 1899.

TISSANDIER (Paul), 17 Avenue Victor Hugo, Paris. Son of Gaston Tissandier. Born 1881. Instructor of aviation. Taught many of the best known aviators.

TURNBULL (W. R.) American Engineer. In the year 1906 commenced to experiment with hydro-aeroplanes; and may be regarded as the originator of all experiments in this direction. The French *Gabardine* of much later date did not differ materially from his early models, while the more recent *Fabre* and the successful *Curtiss Triad* embodied similar ideas.

TURNER (Charles E.) Authority on aviation matters, special aerial correspondent of the *Observer*, etc.

TURNER (Lewis W. F.) British. Chief pilot of the Ewen School, 1912.

TWINING (S. Frisco). Cal. U.S.A. Experimenter with flappers, man propelled, from 1910 onward.

USBORNE (Lieut. Neville F.), R.N. First British naval officer detailed for aerial work. Was appointed to *Clement-Bayard II* in 1909, and subsequently to the first Naval Dirigible. 1912, Naval Wing, R.F.C.

VANNIMAN (Melvin). Built the gondola of the first *Wellman* airship, and intimately concerned with *Wellman II*. Also designed a triplane 1908. Designed *Akron*, 1911. Killed 1911.

VEDRINES. French. Second in the *Daily Mail* £10,000 prize, 1911, in a *Morane*. Won Paris-Madrid, 1911. One of the best known aviators. Began life as a mechanic.

VIVALDI (*late* Lieut.) Italian naval officer. Killed in a *M. Farman*, August, 1910.

VOISIN (Charles), 34 Quai du Point du Tour, Billancourt (Seine), France. Born 1882. Director of *Voisin Freres*. Flew the *Delagrangé I*. in 1906. Induced H. Farman to be interested in aviation.

VOISIN (Gabriel). Brother of above. Born 1880. Chev. Leg. d'Hon. Director of *Voisin Freres*. Commenced to study aviation in 1902 with Archdeacon. Experimented with gliders. Founded *Voisin Freres* in 1903. Designer of the *Voisin* biplane. Killed 1912 in a motor accident.

VUIA. French pioneer, who with a machine somewhat like a *Demoiselle*, flew 6 yards in 1906 and 60 yards in 1907.

WALDEN (Dr.). U.S. citizen. Badly hurt, 1910, in a machine of his own design, but not killed as reported. (See U.S. aeroplanes.)

WALSH (C.F.) American aviator. Winner of various trophies on a *Curtiss*.

WARCHOLOWSKY. Austrian aviator. On October 30th, 1911, made world's record to date by flying 45 minutes with three passengers.

WEILLER (Lazare), 36 Rue de la Bienfaisance, Paris. Officer Leg. d'Hon. Head of the syndicate which in 1908 was responsible for Wilbur Wright coming to France.

WEISS (José). British subject. Pioneer experimenter in aviation. The starting stage used by him for early glider experiments is still to be seen near Arundel Castle, Sussex. Much of our knowledge as to the distribution of weights is due to him.

WELLMAN. An American who hoped to reach the North Pole by dirigible. His first ship came to grief at Spitzbergen. In Oct., he attempted a cross-Atlantic voyage, but failed. (See Vanniman).

WEYMANN (C). American. Won the 1911 Gordon Bennett on a *Nieuport*. Average speed, 78 miles per hour.

WHEELER (R.F.) British Navy. As naval cadet at the age of 15 he obtained his pilot certificate at the Bristol School.

WHITE (Sir George, Bart. LL.D. J.P.) Founder and Chairman of the British and Colonial Aeroplane Co., Ltd. President of the Bristol and West of England Ae. C.

WIDMER. Austrian aviator. In October, 1911, made a flight over the Adriatic, Venice to Trieste.

WILLOWS (E.T.) Cardiff, Wales. British Airship pilot 4. Inventor of the *Willows* airship. Patentee swivelling propellers. Started a dirigible school, 1913.

WISEMAN (Fred T.) American aviator. Flies his own type machine. Has made sensational flights delivering newspapers at farmhouses, April, 1911, also letters.

WRIGHT (Howard). See HOWARD WRIGHT.

WRIGHTS (the) (Orville and Wilbur), 7 Hawthorn Street, Dayton, Ohio, U.S.A. Chevs. Leg. d'Hon. In 1896 the Brothers Wright began to study aerial flight. In 1900 they were making glides. In 1903 they first fitted a motor, and on December 17th of that year made a power flight of about 250 yards. Reports of this were received with incredulity, and right up to July, 1908, when Wilbur Wright appeared in France, many people still regarded the Wrights as a myth. Wilbur Wright easily beat the French machines in circling, etc. He won the Michelin Cup, being up 2 h. 20 m. 23-1/3 sec. Distance 76½ miles official record. Actual, estimated at 93 miles. The exploits of Wilbur Wright put aviation on quite a new footing. Since 1908 the *Wright* type has been surpassed by others; but to the Wrights will always belong the credit of having made a decided step in the science. Wilbur died of typhoid, 1911.

WYNMALEN (Henri). Dutch. Reached 9,121 feet in a *Farman* in 1910, and was then compelled to descend because after 8,000 feet blood oozed from his finger nails and lips. Ae.C.F. pilot 208, 27th August, 1910. Has made many famous flights.

ZENS (Ernest), 3 Rue la Boétie, Paris. Born 1878. Pioneer aviator. On committee of Ae. C. F. First passenger in an aeroplane (carried by Wilbur Wright, 6th September, 1908). Built a monoplane, 1912.

ZEPPELIN (Count). The first Zeppelin dirigible was tried in 1900 on Lake Constance. It made a small speed against a 12-16 m.p.h. wind. It also circled. The experiments exhausted the Count's resources until 1905. Details of this and later *Zeppelins* will be found on the German dirigible pages in Part A.

## CARBURETTERS.

### AUSTRIAN-HUNGARIAN.

DENES FRIEDMANN, 11 Mitterbergasse, Vienna, XVIII.

### BELGIAN.

DASSE (G.), 49 Rue David, Verviers  
FAGARD (J.) & Cie, 7 Rue Bouille, Liege, (*Sthénos*).

### BRITISH.

BROWN & BARLOW, Ltd., 16 Loveday Street, Birmingham  
BURGESS (W. H. M.), 40 Glasshouse Street, London, W. (*White & Poppe*).  
CARBURATION, Ltd., 85 Fleet Street, London, E.C.  
CLAUDEL-HOBSON, 29 Vauxhall Bridge Rd., London, S.W.  
DAVIS PARAFFIN CARBURETTER Co., London  
FENESTRE, CADISCHE & Co., 17 Harp Lane, London, E.C.  
MOSELEY MOTOR WORKS, Birmingham  
SCOTT, ROBINSON, 3 Great Winchester St., London, E.C.  
TRIER & MARTIN, Ltd., Trinity Works, New Church Road, Camberwell, London, S.E. (*T.M.*)  
WAILES (George) & Co., 386-8, Euston Road, London, N.W. (*S.U.*)  
**WHITE & POPPE, Ltd.**, Lockhurst Lane, Coventry  
WOODNUTT & Co., St. Helens, I.W.

### FRENCH.

AMOUDRUZ, 24 Rue d'Armaillé, Paris. (Carburateurs "R.V." et "l'Économé").  
ASTER (Société de Construction Mécaniques (L')), 74, Rue de la Victoire, Paris  
AUFIERE (Ch.), 95 Rue de Flandre, Paris  
BARIQUAND & MARRE (Société), 127 de Oberkampf, Paris  
BELLAN ET FRANTZ, 137 Avenue de Villiers, Paris. ("Le Va-Partout.")  
BOURRIENNE, 18 Impasse Amelot, Paris  
BREUZIN (Ed.) FILS, 26-28 Rue Morand, Paris  
BRIEST, 119 Rue de Rennes, Nantes  
BROUSSET (F.), 5 Rue Leprince, Nogent-sur-Marne. ("Normal" & "Lion").  
CAILLETTE ET NARÇON, 29 Rue de la Plaine, Paris  
CHARRON, Ltd., 7 Rue Ampère, Puteaux  
CLAUDEL (Henri), 41 Rue des Arts, Levallois-Perret  
CLERC & QUANTIN, 21 Rue Tandou, Paris  
COTTIN & DESGOUTTES, Place de Bachut, Lyon  
EMMEL (A.), 278 Boulevard Raspail, Paris  
EVENS, NOLO & Cie, 150, Avenue St-Ouen, Paris  
FILTZ (J.), 13 Avenue du Roule, Neuilly-sur-Seine

GAUTREAU Frères, Dourdan  
GOUBERT, 15 Rue du Pont, Arles  
GRIANOLI (États. L.), 26 Boulevard Magenta, Paris  
GROUVELLE (J.) H. ARGUEMBOURG & Cie, 71 Rue du Moulin-Vert, Paris. ("G. A.")  
HARDING (H. J.), 7 bis, Rue du Débarcadere, Paris. (*J.A.P.*)  
JANVIER (V.), 44 Rue d'Alésia, Paris. ("*Véji.*")  
JANGEY (P.) et Cie, 26 bis, Rue Saint-Didier, Paris  
JOLY FRÈRES, 244 Rue Marcadet, Paris  
JULLIAN FRÈRES & HERAULT, Beziers  
LAURENT FRÈRES, Plandher-Les-Mines  
LONGUEMARE (F. & G.) FRERES, 12 Rue du Buisson-St-Louis, Paris  
MARTHA (L.), 24 Rue du Champ-Les-Mines, Paris  
MENEVEAU & Cie, 15 Rue des Trois-Bornes, Paris  
MERIOT (L.), 22 bis, Rue de Taillandiers, Paris  
PANHARD-LEVASSOR (Etablissements), 19 Avenue d'Ivry, Paris  
PASCAUD, 144 Boulevard Magenta, Paris  
PILAIN (Soc.), 17 Chemin de Monplaisir à Grange-Rouge, Lyon  
POUDEROUX (L.), 9 Rue Waldeck-Rousseau, Paris  
PROGRESSA (Soc.), 3 Passage Moitrier, Levallois-Perret  
SCHMITZ (J.) & Cie, 17 Rue Saussier-Leroy, Paris  
STORR & Cie, 17 Rue Saussier-Leroy, Paris  
STROMBERG MOTOR DEVICES MANUFACTURING Co., 1253 Michigan Avenue, Chicago, U.S.A.  
TOLLET & Cie, 7 Rue de la Charité, Lyon  
VAURS, 38 Rue Brunel, Paris  
VAUTRIAN (L.), 35 Rue Brunel, Paris. ("*Claudet.*")  
VITU (P.), Villa Aline, Rue des Soupirs, Epinal  
WAGNER, 7 Galeme de la Madeleine, Paris  
ZENITH (Soc. du Carburateur) 55 Chemin Feuillat, Lyon-Monplaisir 2 Rue Denis-Poission, Plancher-les-Mines

### GERMAN.

DULONG, 11 Lingstrasse, Berlin  
ESCHER (B.), Sächsische Werkzeug Maschinenfabrik, Chemnitz  
"IDEAL" METALLWARENFABRIK, Opladen (*Ideal A.G.*)  
NEUE VERGASER GESELLSCHAFT, 63 Urbanstrasse, Berlin

### SWISS.

WAGNER (Soc. d'Ind., Suisse d'Outillage), Bate

### U.S.A.

BECKLY RALSDON. 178 Lake Street, Chicago  
BREEZE CARBURETTER Co., 276 Halsey Street, Newark, N.Y.



BUFFALO CARBURATOR Co., 887 Main Street, Buffalo, New York  
BYRNE, KINGSTONE & Co., Kokomo, Ind.  
GOLDBERG MOTOR CAR DEVICES MFG. Co., 1253 Michigan Avenue, Chicago  
HEITGER CARBURETTER Co., 205 West South Street, Indianapolis  
HOLLEY Bros. Co., 661 Beaubien Street, Detroit, Mich.  
KALAMAZOO CARBURETTER Co., Kalamazoo, Mich.  
MARVEL MANUFACTURING Co., 410 S. Meridion Street, Indianapolis  
MYERS (A. J.), 244 West 49th Street, New York. (*G. & A.*)  
SPEED CHANGING PULLEY Co., 758 Washington St., Indianapolis. (*Speed*).  
STROMBERG MOTOR DEVICES MANUFACTURING Co., 1253 Michigan Avenue, Chicago, London, D.E. (*T.M.*)  
WESTERN MOTOR Co., Logansport, Ind.  
WHEELER & SCHEBLER, Indianapolis

## FABRICS FOR AEROPLANES AND DIRIGIBLES.

AUSTRIAN-HUNGARIAN.

METZELER & Cie, 6 Konigstrasse (Gummihof), Vienna VI.

BELGIAN.

DUPT (A. D.), 11 Avenue de Keyser, Antwerp  
ENGLEBERT FILS & Cie, 29 Rue des Venues, Liege

BRITISH.

ACCORDION BOAT Co., 32 Tufton St., Westminster, London, S.W.

"AEROPLATTE." (See Rogers Bros.)

AUTOMOBILE & AERIAL SUPPLY Co., Norwich Union Buildings, Piccadilly, London, W.

AVON INDIA RUBBER Co., Ltd., Melksham, Wilts

BENETFINK & Co., Ltd., Cheapside, London, E.C.

BENEY (R.) & Co., 7 Carlisle St., Oxford St., London, W.

CLARKE (T. W. K.) & Co., Kingston-on-Thames

**CONTINENTAL TYRE & RUBBER Co., (GREAT BRITAIN) Ltd.**, 102 Clerkenwell Road, London, E.C.

DUNLOP RUBBER Co., Ltd., Manor Mills, Aston, Birmingham

FRANKENBURG & Sons, Ltd., Salford, Lancashire

"HARTS," 21 Liverpool Street, E.C.

HUTCHINSON AERO CLOTHS, 70 Basinghall Street, London, E.C.

IOCO PROOFING Co., Ltd., 50, Fraser Street, Bridgeton, Glasgow

IMPERIAL TYRE & RUBBER Co., Brook St., Holborn, London, W.C.

**JONES (Bros., Ltd.)**, 12 York Street, Manchester.

MCLEAN, MCLEAN & Co., 79½ Gracechurch St., London, E.C.

NEW MOTOR & GENERAL RUBBER Co., Ltd., 374 Euston Road, London, W.C.

NORTH BRITISH RUBBER Co., Ltd.:—

1 Long Acre, London, W.C.

Castle Mills, Edinburgh

PEGAMOID (NEW) Ltd., 144 Queen Victoria Street, London, E.C.

ROE (A. V.) & Co., Brownsfield Mills, Manchester

**ROGERS (Bros.)**, 1 Mitre Court, Milk Street, London, E.C. ("*Aviator*" *Ramie*), (*Aeroplatte*).

SPENCER (C. G.) & Sons, 56a, Highbury Grove, London, N.

DANISH.

CONTINENTAL CAOUTOUCHOUC & GUTTA PERCHA Co., 28 Amaliegade, Copenhagen

DUTCH.

CONTINENTAL CAOUTOUCOUC & GUTTA PERCHA Co., 1077 Prinsengracht, Amsterdam

FRENCH.

ALBERTI (L.) (*Harburg-Wien*), 12 Rue d'Enghien, Paris

**BARBET-MASSIN**, Popelin & Cie., 5-7 Rue St. Fiacre, Paris

**BESSONNEAU**, 21 Rue Louis Gain, Angers

CAOUTOUCOUC Manufacture (Soc. du.), 86 Rue Notre Dame-de-Nazareth, Paris

CONTINENTAL CAOUTOUCOUC & GUTTER PERCHA Co., 144 Avenue Malakoff, Paris

DEVILLE (J.), 42 Rue des Jeuneurs, Paris

FALCONNET-PERODEAND (États.), 4 Place Carnot, Choisy-le-Roi (Seine).

GODARD (Louis) (Etabl. Aeronautiques de Paris), 170 Rue Legendre, Paris

HUTCHINGSON (Etablts.) 60, Rue Saint-Lazare, Paris

METZELER & Cie, 1 Rue Villaret-de-Joyeuse, Paris

MICHELIN & Cie, Clermont-Ferrand, Puy de Dôme

OPPENHEIMER NEVEU, 28 Rue Bergere, Paris

PETER (Louis), 107 Rue de Courcelles, Paris

RUSSIAN-AMERICAN INDIA RUBBER Co., 47 Rue St. Ferdinand, Paris

SULFIMATE (Service du), 200 Boulevard Victor Hugo, Clichy (Seine).

TELEPHONES (Soc. Indle. Des), 25 Rue de Quatre Septembre, Paris

TORRILHON (Soc. An. des Anciens Etab. J. B.), Chamalières Puy de Dôme

**VALDENNAIRE (H.)** Adenet & Cie., 21 Rue des Jeuneurs, Paris

GERMAN.

CLOUTH (Franz) (Rheinische Gummiwaarenfabrik, Cologne-Nippes)

CONTINENTAL CAOUTOUCOUC & GUTTA PERCHA Co., 100 Fahrenwalderstrasse, Hamburg

MICHELIN & Cie, Frankenalle 4, Frankfort

RIEDINGER (August), Augsburg, Bavaria

SCHUCKERT & Co. (Elektrizitats A.G.), Nuremburg

ITALIAN.

CONTINENTAL CAOUTOUCOUC & GUTTA PERCHA Co., 36 Via Bersaglio, Milan

MICHELIN & Cie:—

117 Via Livorno, gia via Schina, Turin

14 via Toro, Milan

RUSSIAN.

CONTINENTAL CAOUTOUCOUC & GUTTA PERCHA Co., 11 Boiscbaja Dmitrovka

RUSSIAN-AMERICAN INDIA RUBBER Co., Tregolnik, 138, Canal Abovdny, St. Petersburg

SPANISH.

CONTINENTAL CAOUTOUCOUC & GUTTA PERCHA Co., 5 Calle Fernando el Santo, Madrid

MICHELIN & Cie, 21-23 Calle Sagasta, Madrid

SWEDISH.

CONTINENTAL CAOUTOUCOUC & GUTTA PERCHA Co., Riddoregatan 15, Stockholm

SWISS.

CONTINENTAL CAOUTOUCOUC & GUTTA PERCHA Co., 9 Lowenstrasse, Zurich

U.S.A.

BALDWIN (Captain Thos. S.), Box 78 Madison Square, New York

CONOVER (C. E.) & Co. (*Naiad*), 101 Franklin Street, New York

CONTINENTAL CAOUTOUCOUC & GUTTER PERCHA Co, Muskegon, Mich.

FRENCH AMERICAN BALLOON Co., 4460 Chouteau Avenue, St. Louis

GOODYEAR TIRE & RUBBER Co., Akron, Ohio

MICHELIN & Cie, Milltown (N. T.).

"NAIAD," 101 Franklin Street, New York

STEVENS (Aeronaut Leo), Box 181, Madison Square, New York

## GARMENTS FOR AVIATION.

### AUSTRIAN.

BAUR (R.), 4 Rudolfstrasse, Innsbruck  
GOLDMAN & SALATSCH, 20 Graben, Vienna I.  
MAKOVSKY & Co., 9 Baumannstrasse, Vienna

### BELGIAN.

DEPART (Au), 8 Boulevard Anspach, Brussels  
GAUSSET (F.), 5 Rue du Jardin Botanique, Liege  
HOEBER & Cie, 48 Chemin de Hall, Forest-les-Brus  
REEKIE (A.), 17 Rue Royale, Brussels

### BRITISH.

AEROPLANE SUPPLY Co., Ltd., 111 Piccadilly, London, W.  
BAKER & Co., Ltd., 137 Tottenham Court Road, London, W.C.  
**BURBERYS** 30-33 Haymarket, London, S.W. Basingstoke  
DUNHILL (A.), Ltd., 359 Euston Road, London, N.W.  
GAMAGE (A. W.), Ltd., 126 Holborn, London, E.C.  
HARROD'S STORES, Ltd., Brompton Road, London, S.W.  
JOHNSTON (G.) & Co., 110 Cannon Street, London, E.C.  
NICOLL (H. J.) & Co., Ltd., 114 Regent Street, London, W.  
NORTH BRITISH RUBBER Co., Ltd., Castle Mills, Edinburgh  
PENTON (E.) & Son, 11 Mortimer Street, London, W.  
PIGGOTT (J.), Ltd., 117 Cheapside, London, E.C.  
**ROGERS (Bros.)**, 1 Mitre Court, Milk Street, London, E.C. (*Mascot vests*), (*Aeromac*)  
SAMUEL (Bros.), Ltd., 65 Ludgate Hill, London, E.C.  
SMEE (E.), 403 Oxford Street, London, E.C.

### FRENCH.

ABERDEEN, 1 Rue Auber, Paris  
ARNOUX, 63 Boulevard Malesherbes, Paris  
AUDOUARD, 3 Rue du Commandant, Rivière, Paris  
AUX MARINS, 7 Avenue de la Grande-Armée, Paris  
BARBAN, 67 Rue Rambuteau, Paris  
BAZAR de L'Hotel de Ville, 54 Rue de Rivoli, Paris  
BELLE FERNIERE (La), Rue Saint-Pierre, Caon  
BELLE JARDINIÈRE (La), 2 Rue du Pont-Neuf, Paris  
BERNARD, 153 Rue du Faubourg, Saint-Honoré, Paris  
BINET (E.), 6 Boulevard Diderot, Paris  
BLUET, 154 Boulevard Haussmann, Paris

BOILLAU (M.), 5 Rue d'Tory, Lyon  
BOINET (G.) & Cie, Saint-Quentin  
BON MARCHE (Le), Rue de Sèvres, Paris  
BONNET (G.), 4 Rue de la Bastille, Paris  
BONNIOL, 10 Rue Turbigo, Paris  
BOROWSKY, 32 Rue d'Argout, Paris  
BOURSIN, 61 Rue la Boétie, Paris  
BRUNSCHWIG (Ch.), 39 Rue des Bourdounais, Paris  
BURBERYS, 10 Boulevard Malesherbes, Paris  
BUSSEY (Geo. C.) & Cie, 25 Rue Tronchet, Paris  
BUSVINE & Cie, 4 Rue Marbeuf, Paris  
CAOUTOUCOUC MANUFACTURE (Société du), 86 Rue Notre Dame de-Nazareth, Paris  
CARNAVAL de VENISE (Au), 5 Boulevard de la Madeleine, Paris  
CHAMANSKI & BLOCH, 6 Place des Victoires, Paris  
CHOCQUENET (V.), 31 Rue des Jeûneurs, Paris  
CHOTIN (G.), 34 Rue des Archives, Paris  
CIRET (F.) & Cie, 140 Rue Rivoli, Paris  
COOK & Cie, 23 Rue Auber, Paris  
CRABETTE, 54 Faubourg Saint-Honoré, Paris  
DAMERVAL (A.), 9 Rue Réamur, Paris  
DAROLLES-VINCENT, 22 Rue de Faubourg-du-Temple, Paris  
DAY, 162 Rue du Faubourg-Saint-Martin, Paris  
DEITZ (E.), 56 Rue d'Aboukir, Paris  
DENIAU & Cie, 86 *bis*, Rue de Rome, Paris  
DEWACHTER, 53 Boulevard Voltaire, Paris  
DUGAS, Freres, 10 Boulevard Sébastopol, Paris  
DUROT & LERY, 25 Rue des Trois-Cailloux, Amiens  
DUBESSY (J.), Villefranche  
DUBREUIL & PARMENTIER, 34 Rue Montorquail, Paris  
EGGER & Cie, 2 Rue de la Vrillière, Paris  
ESDERS (Maison Henri), 115 Rue Montmartre, Paris  
FASHIONABLE HOUSE, 16 Boulevard Montmartre, Paris  
FELDSTEIN, 91 Rue des Marais, Paris  
FRAENKEL (H.), 28 Rue du Quatre-Septembre, Paris  
GALERIES LAFAYETTE, 40 Boulevard Haussmann, Paris  
GRANDE MAISON (A La), 7 Rue Croix-des-Petits-Champs, Paris  
HALIMBOURG-AKAR (Etablissements), 1 Places des Victoires, Paris  
HENRY-TREILLE, Marcigny  
HIGH-LIFE, 112 Rue de Richelieu, Paris  
HUTCHINSON (Etablissements), 60 Rue Saint-Lazare, Paris  
KRIEGCK & Co., 23 Rue Royale, Paris  
LACHASSAGNE (E.), Saint-Etienne  
LAMBLIN (A.), 15 Rue Tiquetonne, Paris  
LAMARTINE, 24 Rue des Bons-Enfants, Paris

LECONGE & WILLMANN, 2 Rue du Renard, Paris

LEON, 21 Rue Daunou, Paris

LOUVRE (Grande Magazines du), 164 Rue de Rivoli, Paris

LYON (Grand Bazaar de), 31 Rue de la République, Lyon

MAGNANT & Cie, 117 Rue Réaumur

MAGNE (A.), Moulins, France

MANBY, *les* 19 Rue Auber, Paris

MARCHAL (M.), 30 Rue le Peletier, Paris

MARECHAL (A.), Nevers

MAX-AUSPITZ, 374 Rue Saint-Honoré, Paris

MICHEL JACKSON (A.), 92 Rue Richelieu, Paris

MICHEL JACKSON (E.), Halluin

MENAGERE (À la), 20 Boulevard Bonne-Nouvelle, Paris

METTEZ (Maison), 5 Place de l'Hotel de Ville, Paris

MOLAY (Jacques), 181 Rue du Temple, Paris

MATHAN (G.), 27 Rue Saint-Sabin, Paris

NICOLLE, 29 Rue Tronchet, Paris

OLD ENGLAND

12 Boulevard des Capucines, Paris

114 Via Nazionale, Milan, Italy

OLIVIERI & Co., 101 Rue Claude-Decaen, Paris

PAGUIN (J.) BERTHOLLE & Cie, 43 Boulevard des Capucines, Paris

PARIS-TAILLEUR, 3 Rue du Louvre, Paris

PAYEN (Maison G.), 7 Rue de la République, Lyon

PETIT MATELOT (Au), 41 quai d'Anjou, Paris

PFEIFFR-BRUNET, 17 Rue de l'Ancienne-Comedie, Paris

PRINTEMPS (Magasins du), 70 Boulevard Haussmann, Paris

RAGEUNEAU, 25 Avenue de la Grande-Armée

RÉAUMUR (A.), 82 Rue Réaumur, Paris

REVILLON, Freres, 77 Rue de Rivoli, Paris

RIBBY, 16 Boulevard Poissonnière, Paris

RICOUR, 26 Rue du Bouloi, Paris

RODDY, 2 Boulevard des Italiens, Paris

ROFFY, 2 bis, Rue du Bouloi, Paris

ROUSSEAU, 61 Passage du Havre, Paris

ROYAL TAYLOR, 41 Avenue de Wagram, Paris

RUSSIAN AMERICAN INDIA RUBBER Co., 47 Rue Saint Ferdinand, Paris

SAINT, Freres, 34 Rue du Louvre, Paris

SAMARITAINE, Rue du Pont-Neuf, Paris

SEYNOHA (F.), 249 Rue Saint-Honoré, Paris

"SIEG," 19 Avenue de la Grande-Armée, Paris

SORIN & MARZETTIER, 2 Rue Haudaudine, Nantes, Paris

SPORT (The), 17 Boulevard Montmartre, Paris

STEINMETZ, Freres, 16 Rue Cambronne, Paris

STROM (D. SCHNEIDER & Cie)

16 Rue de la Chaussee-d'Antin, Paris

33 Avenue de la Gare, Nice

TELEPHONE (Société Industrielle des), 25 Rue du Quartre Septembre, Paris

THIERY & SIGRAND, 18 Boulevard Sébastopol, Paris

TORRILHON (J. B.), Chamalieres

TROIS-QUARTIERS (Aux), 17 Boulevard de la Madeleine, Paris

TUNMER (A.) & Co., 27 Rue du Quartre-Septembre, Paris

VELOCE-CLUB (Au), 21 Avenue de la Grande-Armée, Paris

VINCENE, 148 Rue du Temple, Paris

VOLLANT (A.), 34 Boulevard Sébastopol, Paris

WEST END TAILORS, 10 Rue Auber, Paris

WILLIAMS & Cie, 1 Rue Caumartin, Paris

#### GERMAN.

ANWANDER (A.), 22 Sonnenstrasse, Munich

HERTZOG (R.), 15 Breiterstrasse, Berlin

#### ITALIAN.

MARTINY (Manufacture), 5 Via Pietro Micca, Turin

SANGUINETTI (Frat), 8 Corso Vittorie Emanuele, Milan

#### SPANISH

SANCHA (M.), 12 Calle de la Cruz, Madrid

#### SWISS.

GEISTDORFER & Co., 4 Paradeplatz, Zurich

#### U.S.A.

SCANDINAVIAN FUR & LEATHER Co., 16 West 33rd Street, New York

## HANGAR AND SHED BUILDERS.

#### BRITISH.

AEROPLANE SUPPLY Co., Ltd., 111 Piccadilly, London, W.

HARBROW (W.), South Bermondsey Station, London, S.E.

HARRISON, SMITH Buildings, Ltd., Vauxhall Works, Dollinan Street, Birmingham.

HUMPHREYS Ltd., Knightsbridge, London, W.

MORTON, FRANCIS & Co., Ltd., Hamilton Ironworks, Garston, Liverpool.

**PIGGOTT, Bros. & Co., Ltd.**, 220, 222, 224, Bishopsgate, London, E.C.

SMITH (F.) & Co., Carpenters Road, Stratford, London, E.

WIRE-WOVE ROOFING Co. & PORTABLE BUILDINGS Co., 108 Queen Victoria St., London, E.C.

#### FRENCH.

#### BESSONNEAU

29 Rue du Louvre, Paris

21 Rue Louis Gain, Angers

COMPAGNIE AERIENNE, 63, Avenue des Champs, Elysees, Paris

CONSTRUCTIONS DEMONTABLES (Compagnie des), 54 Rue Lafayette, Paris

CONSTRUCTIONS ECONOMIQUES (Société de), 11 Avenue de l'Opera, Paris

DUBOIS et Cie, 7 Rue Saint-Amand, Paris

LAPEYRERE (L.), 44 Rue de l'Eglise, Paris

OFFICE d'AVIATION, 3 Avenue de l'Opera, Paris

RUBEROID (Societe du), 82 Boulevard Beaumarchais, Paris

SAINTE-BEUVE (A.), 196 Quai Jemmapes, Paris

#### GERMAN.

MULLER (A.), 27 Fritcherstrasse, Berlin-Charlottenburg

## HYDROGEN SUPPLIES.

### BRITISH.

BRITISH HYDROGEN Co. (Lane's System), 49-50 Parliament Street, London, S.W.

BRITISH OXYGEN Co., Ltd.:—

Elverton St., Westminster, London, S.W.

Saltley Works, Birmingham

Great Marlborough St., Manchester

Boyd St., Newcastle-on-Tyne

Rosehill Works, Polmadis, Glasgow

**KNOWLES' OXYGEN Co., Ltd.**, Wolverhampton.

WOLF (J.), 15 Seething Lane, London, E.C.

### FRENCH.

ELECTROLYSE FRANCAISE (L'), 4 Rue des Ecluses, Saint Martin, Paris

HYDROGÈNE pour l'Aerostation et l'Industrie (Soc. Francaise de l') (Lane's System), Boulevard Sénart, St. Cloud (Seine et Soise).

HYDROXGENE PUR (L')

22 Rue de Douai, Paris

Marais de Lomme, Lille (Nord)

OXYDRIQUE FRANCAISE (L'), 2 Rue Nouvelle, Paris

## INSURANCE (AVIATION).

### BELGIAN.

MONET (Alfred), 3 Avenue de Cortambert, Bruxelles, Belgium

### BRITISH.

AEROPLANE SUPPLY Co., Ltd., 111 Piccadilly, London, W.

**BRAY, GIBB & Co., Ltd.**, 14 Sherborne Lane, King William Street, London, E.C.

**CAR & GENERAL INSURANCE CORPORATION, Ltd.**, 1 Queen Victoria Street, London, E.C.

DOLAMORE (W. T.), AVIATION INSURANCE BROKER, 199 Piccadilly, W.

FORBES (M. W.) & Co., 15 Queen Street, London, E.C.

GLASGOW ASSURANCE CORPORATION, Ltd., 10 Queen Street, Cheapside, London, E.C.

GOLD (Guy), 1 Cornhill, London, E.C.

KINLOCH (D. A.), 13 Leadenhall Street, London, E.C.

PLANCHE, HEARN & Co., 12 Newgate Street, London, E.C.

WHITE CROSS INSURANCE ASSOC., 1 Cornhill, London, E.C.

### FRENCH.

ASSURANCE SPECIALES d'AUTOMOBILES (Les) 20 Rue Taitbout (Seine), Paris

BANDU DE CHANTPIE (Ch.), 8 Rue Blanche, Paris (Seine)

CAPRON & HAREL, 10 Rue Viollet-le-Duc, Paris

CASANIVA ET GRIBAUMONT, 50 Boulevard Maesherbes, Paris

CAUBERT ET GARNIA (E.), 5 Rue Moreau, Paris

FASTINGER (L.), 8 Rue du Sentier, Paris

HANCIAN (G.), Omnium des Assurance Terrestries, 59 Rue de Chateaudun

HURET (G.), 56 Rue d'Amsterdam, Paris

LAURIERS (Des) et DUMONT, 43 Rue Lafitte, Paris

LAW-CAR, 42 Rue Pergotese, Paris

LE CHARTIR ET DARDONVILLE, 12 Avenue Moatespan, Paris

LEFEVRE (P.), 7 Rue Villaret-de-Joyeuse, Paris

LLOYD (Continental), 17 Rue Druout, Paris

MULLER & DESPIERRES (G.), 26 Rue Etienne-Marcel, France

NICOLLEAU (Auguste), 36 Rue de la Chapelle, Paris

PIEFR (G.), 92 Boulevard Richard-Lenoir, Paris

STEVENS (Pierre), 26 Rue Bergere, Paris

TERRIER (V.), Courtier d'Assurances, 81 Boulevard Sébastopol, Paris

TROLLET (H.), 131 Rue de Rome, Paris

## LUBRICANTS.

### AUSTRIAN.

GERSON BOEHN & ROSENTHAL, 20 Donaueschingenstrasse, Vienna XX.

### BELGIAN.

BENZO-BELGE (la), 11 Boulevard du Régent, Brussels

GUELETTE & Cie, Hug. (*Diamond-Running Oil.*)

### BRITISH.

ADAMS BRITISH OIL Co., Ltd., Plough Bridge, Deptford, London, S.E.

**ANGLO-AMERICAN OIL CO., Ltd.**, 22 Billiter Street, London, E.C.

ANGLO-BOSPHORUS OIL Co., Ltd., Bristol

BOWRING PETROLEUM Co., Ltd., Finsbury Court, London, E.C.

BRITISH MONOGRAM OIL Co., Ltd., 177 The Vale, Acton, London, W.

BUTTERWORTHS, Ltd., 5 Roscoe Chambers, Liverpool

BRITISH PETROLEUM Co., Ltd., 22 Fenchurch Street, London, E.C.

CARLESS, CAPEL & LEONARD, Hope Chemical Works, Hackney Wick, London, N.E.

COUNTY CHEMICAL Co., Ltd., Chemico Works, Bradford Street, Birmingham

DICK & Co., Ltd., 33 Eastcheap, London, E.C.

ENGLEBERT & Co., 119 Finsbury Pavement, London, E.C.

GRINDLEY & Co., Ltd., Poplar, London, E.

KAYE (J.) & Sons, Ltd., 93 High Holborn, London, W.C.

MONOVO Co., Mono Works, Stewart's Road, London, S.W.

O'BRIEN (H.F.) & Co., Broadheath Oil Works, Manchester

PETROLEUM Co., Ltd. (The British), 22 Fenchurch Street, London, E.C.

PRICE'S PATENT CANDLE Co., Ltd., Belmont Works, Battersea, London, S.W.

ROSE (Sir W. & Co.), 66 Upper Thames Street, London, E.C.

STERN-SONNEBORN (A. G.), Royal London House, Finsbury Square, London, E.C.

VACUUM OIL Co., Ltd., Caxton House, Westminster, London, S.W.

WAKEFIELD (C. C.) & Co., 27 Cannon Street, London, E.C.

WHITE, 47 Curtain Road, London, E.C.

WILCOX & Co., Ltd., 23 Southwark Street, London, S.E.

### DANISH.

BEAUVALL (de) Saxlund, 18 Kobmagergade, Copenhagen

MEYER & HENCKEL, 60 Kobmagergade, Copenhagen

### FRENCH.

ACKER, 7 Rue de Bac, Ivry Port (*Auto Victoire.*)

ANDRÉE (A.) Fils (Societe Anonyme), 8 Rue de la Tour-des-Dames, Paris (*Volgaline & Spidoléine.*)

AMELIN & RENAUD, 37 Rue Jean-Jacques-Rousseau, Paris

AMERICAN OIL Co., 42 Rue Lepeletier, Paris

BADIN, 3 Rue de la Mare, Paris

BAILLY, 8 Rue de la Michodiére, Paris

BANTEGNIE & NEVU, 10 Rue Bateau, Aubervilliers

BARBAT (C.), Charenton

BAUD, 24 Rue Saint-Roch, Paris

BAUDOUIN, 32 Quai Saint-Vincent, Lyon

BEDFORD PETROLEUM Co., 67 Boulevard Hausmann, Paris

BÉSANCON (E.), Saint-Denis

BONIFACE, Frères, Sotteville-L-Rouen

BONNEVILLE, ROUILLY & Cie, 27 Rue du Landy, Saint-Denis

BORREL & Fils, 58 Rue de Vincennes, Bagnolet

BOUCHON & BERTRAND, 17 Rue des Bateliers, Clichy

BOUGAULT & Cie, 32 Boulevard Ornano, Paris

BOURGEOIS-OUDRY, 18 Rue de la Paix, Vincennes

BUISINE & Cie, 35 Rue de Viarmes, Paris

BURCKHARDT, 18 Rue Poliveau, Paris (*Auto-Gazoline.*) (*Auto-Moto.*)

CABANNE-NIROUET, 124 Route de Joinville, Champigny-s-Marne

CALISCH-ORESTE, 4 Avenue du Cog, Paris

CAMUS, 5 *bis*, Rue des Rosiers, Paris

CAPET, 61 Rue de la Verrerie, Paris

CATHALIFAUD, 120 Boulevard Magenta, Paris

CAUËT, 18 Boulevard Pagel, Saint-Denis

CAYEUX, Place de Marche-aux-Herbes, Compiègne

CHAILLY, 15 Rue Catulienne, Saint-Denis

CHATELET, 30 Rue de Fontenay, Nogent-sur-Marne

CHAUDIN & Cie, 132 Faubourg, Saint-Denis, Paris

CHEMET, 143 Route de Versailles, Boulogne

CHEMIN (A.), 10 Rue Gresset, Amiens (*Lubrifa.*)

CHICHIGNAUD Au CORNILLON, Saint-Denis

CHOUILLOU, 14 Rue Duphot, Paris

CLAUDY, 92 Rue Neuve-des-Charpennes, Lyon

COLMET & Cie, 70 Rue de Rivoli, Paris

COLUMBRIA (Soc. des Prod. & Pub.), 48 Rue de Paris, Saint-Denis

COSTADAU, 13 Rue Vendome, Lyon (*Golden Oil.*)

DANIEL, 4. Rue Villedo, Paris.

DÉGREMONT, 21 Rue Gudot-de Mauroi, Paris (*Lion.*)

DEGUEANT, Avenue Lagache, Villemonble

DELAGE, Quai d'Issy, 37 Issy-les-Moulineaux

DELETTREZ, 7 Rue Gide, Levallois-Perret (*G.D.*)

DELIGNY, 3 Rue de Buisson-Saint, Louis, Paris

DESCROIX (P.) & LESAGE, 18 Rue de Normande Asnières  
DESSALLE, 39 Rue de Paradis, Paris  
DEUTSCHE (Les Fils de), 50 Rue de Châteaudun, Paris (A.D.) (*Jupiter.*) (*Viscositas.*)  
DION BOUTON (De), 36 Quai National, Puteaux  
DOMONT, 36 Boulevard Ornano, Paris  
DROUOT, 172 Faubourg Saint-Martin, Paris  
FAUCHER, 106 Boulevard Sebastopol, Paris  
FEIGEL, 14 Rae Barbette, Paris  
FERRANDON, 164 Avenue de Valmy, Paris  
FERRON, 59 Boulevard Saint-Denis, Courbevoie  
FIRBACH, 16 Rue Violet, Paris  
FLOQUET, 36 Rue de la Haie-Cog., Paris  
FOURNIER, Frères, 12 Rue Castérès, Clichy  
FRANCO-RUSSE, Cie, 10 Rue Thimonier, Paris (*Newoléine.*)  
GAGNEPIAN, GONNOT & Cie, 109 Rue Victor-Hugo, Levallois-Perret  
GALENA OIL Co., Paris  
GAMARD & LAFLÈCHE, 8 Rue de Thorigny, Paris  
GARDAIR, 71 Rue de Vaugirard, Paris  
GAUBERT, 40 Avenue de la Grande-Armée, Paris  
GÉNÉRAL INDUSTRIELLE (La), 5 Boulevard Voltaire, Paris  
GEORGIER (A.), 8 Route de Flandre, Bourget  
GIRARD, 102 Rue du Gazometre, Montreuil (*La Becanine*)  
GONNOT, 33 Boulevard de la Chapelle, Paris  
GUILLAUD & VALLAT, 36 Chemin, Saint-Matthieu, Lyon  
GUILLET-PUSARD, Fils et Cie, 4 Rue Pocard, Levallois-Perret (*Royal Oil.*)  
GUYENOT (J.), 1 Rue du Printemps, Paris (*Motoléine.*)  
HACHARD, 43 Boulevard, Richard-Lenoir, Paris  
HAMELIN, 65 Rue Rivay, Levallois-Perret  
HAMELLE, 21 Quai de Valmy, Paris (*Valvoline.*)  
HARMIGNIES, 105 Rue de Paris, Ivry Port  
HERZEMBERG, 60 Rue Saint-Mandé, Saint-Ouen  
HUILES & GRAISSES INDUSTRIELLES DE, 18 Rue Gambetta, Nice (*Omnia.*)  
HUILES-VITESSE (Soc. An. des.), Rue des Minimes, Courbevoie  
INDUSTRIELLE GENERALE (L'), 27 Rue la Bruyère, Paris  
LACARRIÈRE & GRAVELIN, 11 Rue de Neuilly, Clichy (*La Preferee.*)  
LAGET, 181 Rue Lafayette, Paris  
LAMPE, Freres, 32 Rue Saint-Lazarre, Paris  
LA SELVE & BOURGEON, 54 Chemin des Cures, Lyon (*Auto Oil*)  
LAVOIX, Le Bourget  
LEBRASSEUR & Cie, 155 Rue de Paris, Saint-Denis  
LEBRASSEUR, 11 Rue de la Vega, Paris  
LECLERC (C.), 33 Rue Auger, Pantin  
LENOIR, 24 Rue Michelet, Pantin  
LENORMAND, 18 Avenue Saint-Germain, Puteaux

LÉONHARD, 14 Rue Coypel, Paris  
L'HERITIER & Cie, 86 Rue de Paris, Saint-Denis  
LILLE & BONNIÈRES, 10 Rue des Pyramides, Paris  
LUBIN, 47 Rue du Liéat, Ivry-Port  
LUBRICATING Oil Co., Route de Sartrouville, Pecg.  
LYNDALI & Cie, 80 Rue Taitbout, Paris  
MACKAY, 2 Cité Trévis, Paris  
MAILLET, 9 Rue Alfred Condre, Abbeville  
MALICET & BLIN, 103 Avenue de la Republique, Aubervilliers (*Mab.*)  
MANÇEAU, 60 Rue de Flanders, Pantin  
MARÉCHAL, 75 Avenue du Chemin-de-Fer, Le Vestinet  
MARTIN (V.), 50 Boulevard de Strasbourg, Paris  
MARVILLE & Cie, Rueil  
MAUPRÉ, 112 Rue de la Chapelle, Paris  
MICHEL, 15 Rue Ferragus, Aubervilliers  
MORIN, 48 Rue de l'Aqueduc, Paris  
NANTERRE, 18 Rue Gambetta, Nice (*Omnia.*)  
NASSOY & RIBAUD, 78 Rue Charles-Nodier, Pantin (*Colzarine*)  
NICKMILDER, 82 Rue Daquerre, Paris  
NOBLET, 1 Rue Pastuer, Ivry-Port  
NORTZ, 29 Boulevard Sébastopol, Paris  
OLEO, 30 Rue Perrier, Levallois-Perret (*Oleomoto*)  
OLEONNAPHTES (Société Anonyme), 164 Avenue de Paris, Saint-Denis  
OLÉONNAPHTES ÉMULSIONNES (Société Anonyme), 3 Avenue Victor-Hugo  
ORANGE & Cie, 432 Avenue de Paris, Saint-Denis  
PELON, 76 Avenue de la Republique, Paris  
PENNSYLVANIA OIL Co., 39 Rue Sainte-Cécile, Marseilles  
PETROLES OIL Co., 2 Rue Fongate, Marseilles (*Onctua.*)  
PEUGEOT, Freres, 71 Avenue de la Grande-Armée, Paris Valentigney  
PIETRATERRA (A.), 10 Rue des Augustins, Argenteuil  
POURCHEIROUX, 41 Rue Saint-Ferdinand, Paris  
POULET & TAYART, 108 Avenue de la Republique, Aubervilliers  
PRADERE & Cie, 16 Rue du 14-Juillet, Pre-Saint-Gervais (*Virginia*)  
QUERVEL, 35 Rue du Port, Aubervilliers (*Kervoline*)  
RASTIT (H.), 38 Rue Bicolos, Marseilles  
RECORD, 27 Quai Gailleton, Lyon  
REGNIER, Fils & RODDE, 11 Rue Etienne-Dolet, Paris  
RENAUD-LEVEQUE & Cie, 37 Rue Jean-Jacques-Rousseau, Paris  
RENAULT (V.), 145 Avenue, Parmentier, Paris  
REVAUX, 63 Boulevard Thiers, Amiens  
RICBOURG, 19 Quai aux Fleurs, Paris  
RINCK, Fils, 66 Rue de Rivoli, Paris  
ROBERT, 25 Rue Drouot, Paris  
RONDEL, 101 Rue Marceau, Montreuil



RONDEL (Ch.), 57 Rue de Saint-Mandé, Montreuil  
SAUTET, Freres, 99 Route d'Orléans, Montrouge  
SIMONET (L.), 45 Rue Gambetta, Nancy  
SIMON-ROCHE, 17 bis, Avenue du Mans, Tours (*Auto Sims*)  
SIVAN, 8 Place de l'Evêsché Marques, Fréjus (*Record, Aeroline, Motord*)  
STANDARD OIL Works, 69 Rue d'Hauteville, Paris  
STORACE (B.), 15 Rue de Paris, Nice  
SYLVESTER (E.), 6 Rue Nationale, Rouen (*W.S.*)  
TESSE, 15 Rue de Surène, Paris  
TORRE & Cie, 112 bis, Rue de Paris, Vincennes  
TOURNEL, 18 Avenue d'Italie, Paris  
TRABET (L.), 1 Rue Amelot, Paris (*Trabeoline*)  
VACUUM OIL Co., Ltd., 34 Rue de Louvre, Paris  
VILLENEUVE (A.), 1 Boulevard Saint-Jacques, Paris  
WALLACH & Cie, 60 Avenue de la Republique, Aubervilliers  
WALLET, 12 Rue Rennequin, Paris  
WILSNER (G.), 29 Rue de Neuilly, Clichy  
ZEMMER, 91 Rue Petit, Paris

#### GERMAN.

DEPAUW & Cie, 6 Rue de la Linère, Brussels  
DEUTSCHE LVERKE, 1 Prinz-Louis, Ferdinandstrasse, Berlin  
PETROLEUM RAFFINERIE, Breme (*Veloscol*)  
SPILCKE, 94 Chausseestrasse, Berlin  
STERN-SONNEBORN (A. G.), 21 Ritterstrasse, Berlin S. 42  
SÜDDEUTSCHE OELWERKE, Fribourg-en-Brisgau  
VALVOLINE OIL Co., 7 Hobzbrücke, Hambourg  
VOGT & Cie, Görlitz (*Vostol*)

#### ITALIAN.

ARNOLDI & Cie, 37 Via Paolo do Cannobio, Milan  
CECCARELLI, TEDESCHI & Cie, Corso XXII., Marso, 34, Milan (*Teuff*)  
CORLIÈ RE, 8 Via Santa-Azata, Boulogne  
FOLTZER (E.), Rivarolo-Lugure, Genes  
KOCH (O.), 50 Via Abbadesse, Milan  
MIRAGOLI & PETSATORI, 67 Foro Bonaparte, Milan  
OLEUM, Galleria Nazionale, Turin  
PETROLIO, 76 Piazza Cinque Lampade, Genes  
REINACH & Cie, 90 Via Lario, Milan (*Oleoblitz*)  
VOLPATO & Cie, 11 Via Santa-Maria-Fulcornia, Milan

#### ROUMANIAN.

TRAJON, Bucharest, Roumania

#### RUSSIAN.

CHABANIAN (R.), Batoum-Bakou  
KAISER (R.), Baku  
MALLARD, Caucase, Batoum  
NOBEL, Freres, St. Petersburg  
PITOEFF & Cie, Tiflis  
SCHIBAEFF & Cie, Bakau  
TER AKOPOFF, 3 Place Isaac, St. Petersburg

#### SPANISH.

FONTAGUD, 6 Fuentes, Madrid  
OLEON Co., 13 Asalto, Saragossa  
USERA (De), 47 Legdnitos, Madrid  
VACUUM OIL Co., 598 Cortes, Barcelona

#### SWISS.

GRISARD (G.), 302 Route de Greuzach, Bâle  
HALLER, 8 Splugenstrasse, Zurich  
HEUMANN (A.) & Cie, Winterthur  
HUILES MINERALES, Route de Frontenex, Geneva  
LAMBERCIER (J.) & Cie, Geneva  
LUMINA (S. A.), Geneva-Vollandes  
MOEBIUS (H.) & Fils, Bâle  
OMNIA (Maison), Chêne-Bourg, Geneva  
SCHMID, 133 Murtenstrasse, Berne

#### U.S.A.

DIXON (J.) CRUCIBLE Co., Jersey-City, New York, (*Graphite*)  
KEYSTONE LUBRICATING Co., Philadelphia  
WHITE & BAGLEY Co., Worcester (*Oilzum*)

## MAGNETOS.

### AUSTRIAN.

DENES & DRIEDMAN, 11 Mitterbergasse, Vienna XVIII.  
ERBEN (S.) & ARNOLD FRIEDMANN, 14 Stubenring, Vienna I.

### BELGIAN.

BOSCH MAGNETOS, 121 Rue de l'Instruction, Brussels  
PERNSTEIN (Ateliers), 8 Rue Laporte, Liege-Nord

### BRITISH.

#### BOSCH MAGNETOS

40-42 Newman Street, London, W.C.

28 Store Street, Tottenham Court Road, London, W.C.

BRITISH TELLIER Co., 10 Coburg Place, Hyde Park, London, W.

**EISEMANN MAGNETO Co.**, 43 Berners Street, London, W.

FULLER (J. C.) & Son, Woodland Works, Wick Lane, Bow, London, E.

**MEA MAGNETO Co.**, Gresse Buildings, Stephen Street, Tottenham Court Road, London, W.

NILMELIOR (Société d'Electricité), 36-37 Alfred Place, Tottenham Court Road, London, W.C.

RICHES (G. T.) & Co., 19 Store Street, Tottenham Court Road, London, W.C.

SIMMS MAGNETO Co., Ltd., Welbeck Works, Kilburn, London, N.W.

VAN RADEN & Co., Ltd., Great Heath, Coventry.

### DUTCH.

BOSCH MAGNETOS, Willem Van Rijn, Keizergracht 181, Amsterdam

### FRENCH.

BARDON (L.), 61 Boulevard National, Clichy

BAUDOT ET PAZ, 22 Avenue de la Grande-Armée, Paris (*Simms.*)

BOIN, 33 Rue du Four, Paris

#### BOSCH MAGNETOS

Depôt 295 Avenue de Saxe, Lyon

17 Rue Theophile-Gautier

BREGUET (Maison), 19 Rue Didot, Paris

DEBEAUVE, 68 Rue de Sevres, Paris (*Vestale*)

**EISEMANN & Co.**, Lavalette & Cie., 175 Avenue le Choisy, Paris

EXTRA. (*See Giffard.*)

GIANOLI, 28 Boulevard Magenta, Paris

GIBAUD, 309 Rue de Faubourg, Saint-Antoine, Paris

GIFFARD, 283 Rue des Pyrénées, Paris (*L'Extra*)

GIRARDEAU (A.), 7 Rue Scribe, Paris

GUENET, 5 Rue Montmorency, Paris

GUILLOU, 41 Rue de Bagneux, Montrouge

HENRIQUE, 54 Quai de Courbevois, Courbevois

HERDTLE & BRUNEAU, 93 Rue Pelleport, Paris

HOMMEN (H.), 38 Rue de Turenne, Saint-Etienne

HYDRA (Société de le Magneto), 11 Rue Charcot, Neuilly-sur-Seine

ILIYNE-Berline, 8 Rue des Dunes, Paris

INVICTA (Société) (Hamille et Cie), 5 Rue Deves, Neuilly-sur-Seine

JUSTON & Cie, 62 Rue du Chemin-Vert, Paris

**MEA MAGNETO**, Feld-Dengen, 157 av. Malakoff, Paris

MONTBARBON (Société), 147 bis, Rue de Villiers, Neuilly-sur-Seine (*S.A.M.*)

NIEUPORT (Société Anonyme des Appareils Electriques), 9 Rue de Seine, Suresnes

NILMELIOR (Société), 49 Rue Lacordaire, Paris

SIMMS MAGNETO Co., Ltd., 12 Rue de Courcelles, Levallois-Perret

STUART & STICHTER, 18 Avenue des Ternes, Paris (*Splitdorf*)

UNTERBERG & HELME, 166 Rue Lafayette, Paris (*U.H.*)

### GERMAN.

BERGMANN'S INDUSTRIEWERKE, Gaggneau (*G.m.b.H.*)

BOSCH MAGNETOS, 11 Hopperlastrasse, Stuggart

**EISEMANN & CO.**, 61 Rosenbergstrasse, Stuttgart

FIELDER (W.), Eisenach (*Ruthardt*)

HAENDLER (A.), 52 Heidestrasse, Berlin

**MEA** (*G.m.b.H.*), Stuttgart

RAPID ACCUMULATOREN & MOTOREN WERKE, 149 Hauptstrasse, Schoneberg-Berlin

RUTHARDT & Co., 77 Olachstrasse, Stuttgart

SCHOELLER (A.), Frankfort

TAUNUS ZUNDERFABRIK (*G.m.b.H.*), Frankfort

UNTERBERG & HELME, Durlach, Baden

WECKERLEIN & STOCKER, 7 Wodanstrasse, Nuremberg (*Moris*)

### ITALIAN.

BOSCH MAGNETOS, 18 Via San Vittore, Milan

**EISEMANN & Co.**, Ditta Secondo Pratti, 32 Carlo-Alberto, Milan

LUCINI (Enrico), 3 Via Petrarca, Milan

### SWEDISH.

BOSCH MAGNETOS, Fritz Egnall, Norra Bantorget 29, Stockholm

### SWISS.

KESSERLING (F.) & Cie, Schaffhouse

KOMET, 95 Brunastrasse, Zurich

U.S.A.

BOSCH MAGNETOS:—

160 West St., 56th Street, New York.

223 & 225 West 46th Street, New York.

1253 Michigan Avenue, Chicago

357 Van Ness Avenue, San Francisco

DAYTON ELECTRIC MANUFACTURING Co., 98 St. Clair Street, Dayton, Ohio

DOW MANUFACTURING Co., Braintree

FAWN RIVER MFTG. Co., Constantine, M.

FISCH (Geo. L.), 1451 Michigan Avenue, Chicago

HEINZE ELECTRIC Co., Lowell, Mass.

HOLTZER, CABOT ELECTRIC Co., Boston (H.C.)

K.W. IGNITION Co., 30 Power Avenue, Cleveland, Ohio

MEA MAGNETOS, Marburg Bros., Inc., U.S. Rubber Buildings, New York. Also Detroit and Chicago.

MOTSINGER DEVICE MFTG. Co., Pendleton, Ind.

PITTSFIELD SPARK OIL Co., Dayton

REMY ELECTRIC Co., Anderson, Ind.

SPLITDORF Co.

261-265 Walton Avenue, New York.

138th Street, New York.

## MISCELLANEOUS ACCESSORIES.

### BELGIUM.

WANSON (Maurice), 10 Rue Jean Stas, Brussels

### BRITISH.

AEROS, Ltd., 139 St. James's Street, Piccadilly, London.

AEROPLANE SUPPLY Co., Ltd., 111 Piccadilly, London, W.

BRITISH AMERICAN Co., 300-33 Widdrington Road, Coventry

BRITANNIA ENGINEERING Co. (1910), Ltd., Britannia Works, Colchester

BRITISH EMALLITE Co., Ltd., 30 Regent Street, London, S.W.

BRITISH INSULATED & HELSBY CABLES, Ltd., Warrington

BRITISH LOW ACCESSORIES Co., Ltd., 15 Great St. Helen's, London, E.C.

BONN (J.) & Co., Ltd., 97 New Oxford Street, London, W.C.

BOWDEN PATENTS, Ltd., Baldwin Gardens, London, W.C.

BROOKS (J.B.) & Co., Ltd., Criterion Works, Birmingham

BROWN (Bros.), Ltd., Birmingham

BRAMPTON (Bros.), Ltd., Birmingham

**BURBERRYS**, The Haymarket, London, S.W. (*Aviation Garments*)

CENTRAL NOVELTY Co., 99 Snow Hill, Birmingham

CHATER, LEA, Ltd., 114 Golden Lane, London, E.C.

CLARK (T. W. R.) & Co., Crown Works, High Street, Kingston-on-Thames

**COAN (Robt. W.)**, 219 Goswell Road, London, E.C. (*Aluminium Castings.*)

COWEY ENGINEERING Co., Ltd., 1 Albemarle Street, London, W.

CRAMPTON & Co., 73 Queen Victoria Street, London, E.C.

**CROSLEY, LOCKWOOD & SON**, 7 Stationer's Hall Court, London, E.C. (*Publishers*)

DING, SAYERS & Co., Elm Gardens, Mitcham, Surrey

DOBBIE McINNES, Ltd., Glasgow, N.B.

DRESSER & GARLE, Regent House, Regent Street, London, W.

**DRUMMOND BROS., Ltd.**, Ryde's Hill, Guildford

**EISEMANN MAGNETO Co.**, 43 Berners Street, London, W.

ESSEX ACCUMULATOR Co., 499 Grove Green Road, Leytonstone, London, N.E.

EVANS (Geo.) & Co., 94 Albany Street, Regent's Park, London, N.W.

FLATHER (W. T.), Ltd., Standard Steel Works, Sheffield

FRASER BEGG & Co., Ilford.

FONTEYN & Sons, 76 Newman Street, London, W.

FOULIS (Wilfred), Ltd., Sunbury News, Belford Road, Edinburgh

GENERAL AVIATION CONTRACTORS, Ltd., 30 Regent Street, London, S.W.

**GEOGRAPHIA DESIGNING & PUBLISHING Co., Ltd.**, 33 Strand, London, E.C. (*Maps, etc.*)

HAIM (N. S.), 69 Mark Lane, London, E.C.

HANDLEY PAGE, Ltd., 72 Victoria Street, London, S.W.

HARRIS & SAMUEL, 10 Dean Street, Oxford Street, London, W.  
**HASLER TELEGRAPH WORKS**, 26 Victoria Street, London, S.W. (*Indicators*)  
HELLEKEN, Ltd., 133 Upper Thames Street, London, E.C.  
HILL (ROWLAND) & Sons, Ltd., Albion Foundry, Coventry  
HOBSON (H. H.), Ltd., 29 Vauxhall Bridge Road, London, S.W.  
HORA (E. & H.), Ltd., 36-38, Peckham Road, London, S.E.  
**HOYT METAL Co. OF GT. BRITAIN, Ltd.**, 26 Billiter Street, London, E.C.  
HUNTSMAN (B.), Attercliffe, Sheffield  
HURLIN (J.) & Son, 191 Cambridge Road, London, E.  
JENNINGS, GUILDING & Co., 60 Southgate Street, Gloucester  
**JONES Bros., Ltd.**, 12 York Street, Manchester (*Fabrics, etc.*)  
KALKER (E.) & Co., Much Park Street, Coventry  
KEMPSHALL TYRE Co., 1 Trafalgar Buildings, London, W.C.  
KIRKBY BANKS SCREW Co., Ltd., Meadow Lane, Leeds  
LAMPLOUGH & Sons, Ltd., Albion Works, Cumberland Park, London, N.W.  
**MALLINSON (Wm.) & Sons**, 130-138 Hackney Road, London, N.E.  
MARSH (Bros.) & Co., Ltd., Ponds Steel Works, Sheffield  
MARKT & Co., 6 City Road, London, E.C.  
**MEA MAGNETO Co.**, Gresse Buildings, Stephen Street, Tottenham Court Road, London, W.  
MELHUISE (R.), Ltd., 50 Fetter Lane, London, E.C.  
MELLIN (F.) & Co., Salisbury Road, Kilburn, London  
M. P. G. Co., 98 Tollington Park, London, N.  
MOGUL TYRE Co., Ltd., 15 Carlton House, Regent Street, London, W.  
MOTOR ACCESSORIES Co., 55 Great Marlborough Street, London, W.  
MOTOR AVIATION Co., Ltd., 628 Martin's Lane, London, W.C.  
NOBLES & HOARE, Ltd., Cornwall Road, Stamford Street, London, S.E.  
NORTH BRITISH RUBBER Co., Ltd., Castle Mills, Edinburgh  
**OWEN (Joseph) & Sons, Ltd.**, 199a Borough High Street, London, S.E. (*Aeroplane Woods*)  
PALMER (L. N.), 9a Trevelyan Road, Tooting, London, S.W.  
PALMER TYRE Co., Ltd., Shaftesbury Avenue, London, W.C.  
**PIGGOTT Bros. & Co., Ltd.**, 220, 222, 224, Bishopsgate, London, E.C.  
POLDI STEEL Works, Napier Street, Sheffield  
RANDALL (J. H.) & Co., Green Street Works, Paddington Green, London, W.  
REASON MFTG. Co., Ltd., Lewes Road, Brighton  
RENOLD (Hans), Ltd., Progress Works, Brook Street, Manchester  
ROE (A.V.), Gt. Ancoats Street, Manchester  
**ROGERS Bros.**, 33 Aldermanbury, London, E.C. (*Fabrics, etc.*)  
ROLLETT (H.) & Co., "Avia Works," Coldbath Square, Rosebery Avenue, London, E.C.  
ROSS, COURTNEY & Co., Ltd., Ashbrook Road, Upper Holloway, London, N.  
RUBERY, OWEN & Co., Darlaston, Staffs.  
RUTT (A.) 85 Cannon Road, Bromley  
SCHAFFER & BUDENBERG, Whitworth Street, Manchester  
SEEBOHM & DUCKSTAHL, Ltd., Dannemora Steel Works, Sheffield  
SHORT (Bros.), Eastchurch, Sheppey

SMITH (F.) & Co., Ltd., Wire Manufacturers, Caledonia Works, Halifax  
SNOWDEN & Sons, 427 Norwood Road, London, S.E.  
SPEAR & JACKSON, Ltd., Aetna Works, Sheffield  
SPIRAL TUBE & COMPONENTS Co., Caledonian Street, King's Cross, London, N.  
SPENCER MOULTON (G.) & Co., Ltd., 77-9 Cannon Street, London, E.C.  
STEWART & CLARKE MFTG. Co., 11 Denmark Street, Charing Cross, London, W.  
**THORN & HODDLE ACETYLENE Co., Ltd.**, 151 Victoria Street, London, S.W.  
TIMPERLEY (Chas. B.), 86b Snow Hill, Birmingham  
TORMO MFTG. Co., 67 Bunhill Row, London, E.C.  
UNITED MOTOR INDUSTRIES, Ltd., 45-6 Poland Street, London, W.  
UNIVERSAL AVIATION Co., 166 Piccadilly, London, W.  
VAN DE RADEN & Co., Ltd., Great Heath, Coventry  
**VANDERVELL (C. A.) & Co.**, Warple Way, Acton Vale, London, W.  
VENESTA, Ltd., 20 Eastcheap, London, E.C.  
WARWICK WRIGHT, Ltd., 110 High Street, Manchester Square, London, W.  
WEBSTER & BENNETT, Ltd., Atlas Works, Coventry  
WEST LONDON SCIENTIFIC APPARATUS Co., Ltd., Premier Place, High Street, Putney, London, W.  
WHITELEY EXERCISER Ltd., 35-37 Southwark Bridge Road, London, S.E.  
**WHITEMAN & MOSS**, 8 Moor Street, Cambridge Circus, London, W.C.

#### FRENCH.

ACIERIES DE FIRMINY, Firminy, Loire  
BARDOU, CLERGET & Cie, 12 Boulevard Sebastopol, Paris  
**BESSONEAU**, 29 Rue du Louvre, Paris  
BLOT-GARNIER & CHEVALIER, 9 Rue Beudant, Paris  
BORDE (I.), 99 Boulevard, Haussmann, Paris  
BOREL et Cie, 11 Chemin de Pré-Gaudry, Paris  
CARPENTIER (J.), 20 Rue Delamore, Paris  
CHAPMAN (H.), Rue Laffitte, Paris  
CACATRE, 35 Boulevard Saint-Jacques, Paris  
**DOUTRE (La Ste. An des Appareils d'Aviation)**, 58 Rue Tait bout, Paris  
DUCOMET, 11 Rue d'Abbeville, Paris  
GAUDET (A.), 7 Avenue de Montreuil Fontenay-sous-Bois, Seine  
GIRAUD (Ainé), 49 Rue Greffulhe, Levallois-Perret  
GODARD (Louis), 170 Rue Legendre, Paris  
GOMES (A. C.) & Cie, 63 Boulevard Haussmann, Paris  
GROSSIORD (A.), Saint-Maurice, Seine  
HANNOYER (F.), 69 Avenue Parmentier, Paris  
HUE (E.), 63 Rue des Archives, Paris  
LADIS LEWKOWICZ, Ervauville, Loviet  
LEFEBVRE & Cie, 76 Avenue de la République, Paris  
LEVESQUES, Rue des Haudriettes, Paris  
LUNKEN VALVE Co., 24 Boulevard Voltaire, Paris

MAXANT, 38 Rue Belgrand, Paris  
MAZELLIER ET CARPENTIER, 20 Rue Delambre, Paris  
PAREME (J.), 203 Rue Lafayette, Paris  
PELON, 76 Avenue de la République, Paris  
PELTRET & LAFAGE, 4 Rue des Rigoles, Paris  
PERE (J.), 46 Boulevard Magenta, Paris  
POIRELLE (Vve) & DOURDE, 4 Place Thorigny, Paris  
PROTAIS, 12 Rue Montbrun, Paris  
RICHARD (J.)

25 Rue Melingue, Paris

10 Rue Halevy, Paris

ROEBLING'S (J. A.) & Sons Co., Trenton, New Jersey  
SCHAEFFER & BUDENBERG, 105 Boulevard Richard-Lenoir, Paris  
SEEBOHM & DIECKSTAHL, 4 Rue Sanite-Ann, Paris  
SOCIETE GENERALE D'APPAREILS DE CONTROLE, 105 Rue de la Convention, Paris  
**VALDENAIRE (H.), ADENET & Cie**, 21, rue des Jeûneurs, Paris (*Fabrics*).

GERMAN.

BAMBERG (Carl), Berlin-Friedenau  
BASSE & SELVE, Altena  
BUNGE (B.), Oranienstrasse, 20 Berlin, So. 26  
DEUTCHEN WAFFEN-V-MUNITIONSFABRIKEN, Dorotheenstrasse 43-41, Berlin N.W.  
41  
**EISEMAN MAGNETO Co.**, 61 Rosenbergstrasse, Nuremberg.  
FUESS (R.), Steglitz  
HACKENSCHMIDT (Ch.), 7 Kramergasse, Strasbourg  
**MEA MAGNETO**, S. Union Werke G.m.b.H. Feurbach-Stuttgart  
SPINDLER & HOYER, Goettingue

U.S.A.

BRETZ (J. S.), & Co., Times Buildings, Byrant  
BROWN & Co., 1070 Clinton St., Syracuse, New York  
CALIFORNIA AERO MFTG. & SUPPLY Co., 441-3 Golden Gate Avenue, San Francisco  
CHURCH AEROPLANE Co., Brooklyn, New York  
DELTOUR (J.), Inc., 496th Avenue, New York  
FRASSE (Peter A.) & Co., 408 Commerce Street, Philadelphia  
PEDERSEN MANUFACTURING Co., 636-644, First Avenue, New York  
PENNSYLVANIA RUBBER Co., Jeannette, Pa.  
RUBEL (R. O.), Louisville, Ky.  
RUDOLPH (W. F.), Broad Street, Pa.  
SCOTT, Bros., Cadiz, Ohio  
STUPAR, 9626 Erie Avenue, Chicago  
WEAVER-EBLING AUTOMOBILE Co., 2230 Broadway 79th Street, New York  
WITTEMANN (C. & A.), 17-19 Ocean Terrace, Staten, 1st, New York

WILLIS (E. J.) & Co., 85 Chambers Street, New York  
WILSON & SILSBY, Yacht Sailmakers, Rowe's Wharf, Boston, Mass.

## PACKERS AND SHIPPERS.

### BRITISH.

AEROPLANE SUPPLY Co., Ltd., 111 Piccadilly, London, W.  
CARBURINE. (See Gas Lighting Improvement Co.)  
DRESSER & GARLE, Regent House, Regent Street, London, W.  
MOUNT (J. C.) & Co., 101, Grosvenor Road, London, S.W.

### FRENCH.

BRAVARD, 40 Rue de l'Arbre-Sec Lyon, Rhone  
GERFAUD (C.), 26 Rue du Chateau-d-Eau, Paris  
LANGSTAFF, EHRENBERG & POLLACK, 12 Rue d'Enghien, Paris  
PAYSSE & Cie, 22 Rue Amperé, Paris

### ITALIAN.

AMBROSSETTI (G.), 32 Via Nizza, Turin

### U.S.A.

BRINE (B. S.), Transportation Co.

## PATENT AGENTS (Aerial Specialists).

### BELGIAN.

HAMEL (J.), Liege  
WUNDERLICH & Cie., Brussels.

### BRITISH.

BREWER & SONS, 35 Chancery Lane, London, W.C.  
CHATWIN, HERSCHELL & Co., 253 Grays Inn Road, London, W.C.  
EDWARDS (ARTHUR) & Co., Chancery Lane Station Chambers, Holborn, London, W.C.  
MARKHAM & FRANCE, Dudley House, Southampton  
ROGERS (F. M.) & Co., 21 Finsbury Pavement, London, E.C.  
ROOTS (J. D.) & Co., Thanet House, Temple Bar, London, E.C.  
**STANLEY POPPLEWELL & Co.**, 38 Chancery Lane, London, W.C.  
THOMPSON (W. P.) & Co., 285 High Holborn, London, W.C., and 6 Lord Street, Liverpool  
WITHERS (J. S.) & SPOONER, 323 High Holborn, London, W.C.

### FRENCH.

ARMENGAUD, Paris  
BLETRY (C.), 2 Boulevard de Strasbourg, Paris  
BRANDON FRÈRES, Paris  
DUPONT & ELLUIN, 42 Bd. Bonne-Norwelle, Paris  
JOUVE (Ad), Marseilles  
MESTRAL & HARLÉ, 21 rue de la Rochefoucault, Paris  
PICARD, 97 Rue St. Lazare, Paris.  
WEISMANN & MARX, 90 rue d'Amsterdam, Paris

### GERMAN.

ANSBERT VERREITER, Berlin W. 57  
BEZUGSQUELLEN-AUSKUNFTEI, Berlin.

### ITALIAN.

BARZANO & ZANARDO, via Bagutta 24, Milan

### SPANISH.

BOLIBAR (G.), Barcelona.

### U.S.A.

EVANS (Victor J.) & Co., 724-726, Ninth St. N.W. Washington, D.C.  
OWEN (Richard B.), Dept. 5, Owen Building, Washington, D.C.

## PETROL.

### AUSTRIAN.

LEDERER (W.) (*Galizche Karpathen Petroleum A.G.*), Galicia  
NAPHTE UNGARISCHE, 33 Vaczi-Korut, Budapest, Hungary  
RUSSIAN-AMERICAN OIL Co., 42 Zozsef, Budapest VIII., Hungary

### BELGIAN.

BELGIAN BENZINE Co. (*Motogazolin*), Haren-Nord  
MOTTAY & PISCART (*Motocarline*), Haren-Nord-lez-Brussels

### BRITISH.

ANGLO-AMERICAN OIL Co., Ltd., 36-38 Queen Anne's Gate, Westminster, London, S.W.  
(*Pratt's*)

BOWLEYS & Son, Wellington Works, Battersea, London, S.W.

BOWRING PETROLEUM Co., Ltd., 5, Billiter Avenue, E.C.

BRITISH PETROLEUM Co., 22 Fenchurch Street, London, E.C. (*Shell*)

CARLESS, CAPEL & LEONARD, Hope Chemical Works, Hackney Wick, London, N.E.

GAS LIGHTING IMPROVEMENT Co., Ltd. (*Carburine.*)

7 Bishopsgate Street Without, London, E.C.

Royston Castle, Shore Road, Granton, Edinburgh

PETROLES DE GROSNYI (Russie) (P.G.R.), 101 Leadenhall Street, London, E.C.

### BRITISH COLONIES, etc.

WILSON (J.), 119 Rue Common, Montreal, Canada

### DANISH.

BEAUVAL & SAXLUND, 18 Kobmagergade, Copenhagen

MEYER & HENCKEL, 60 Kobmagergade, Copenhagen

### FRENCH.

DEUTSCH (Les de) (*Moto-Naptha*), 50 Rue de Chateaudun, Paris

FANTO (Cie Des Petroles), 74 Rue St. Lazare, Paris

FENAILLE & DESPEAUX (*Benzo Moteur*), 11 Rue de Conservatoire, Paris

FIRBACK (E.), 16 Rue Violet, Paris

GERFAUD (C.), 26 Rue du Chateau-d-Eau, Paris

GRAMMONT (Raffineries) (*Lesourd*), Tours

GUILLAND & VALLET, 36 Chemin St. Mathieu, Lyon

LANGSTAFF, EHRENBERG & POLLACK, 12 Rue d'Enghien, Paris

LASSAILLY (L.), 12 Rue d'Oney, Vitry, Seine

LILLE, BONNIERES ET COLOMBES (Soc. Anym.) (*Vaporine & Spiritol*), 10 Rue des Pyramides, Paris

NAPHTE CASPIEBBE ET DE LA MER NOIRE (Société), 26 Rue Lafitte, Paris

PETROLES (Cie Generale des) (*Naphtacycle*), 2 Rue Fongate, Marseilles

PETROLES (Cie Industrielle des), 12 Rue Blanc, Paris

PETROLES DE BINAGADI BAKOU (Soc. des), 11 Place des Vosges, Paris

RAFFINERIE DE PETROLE DU DUNQUERQUE (ENERGIE) (*Touriste*), 24 Rue Joubert, Paris

RAFFINERIE DE PETROLE DU NORD, 26 Rue d'Enghien, Paris (*Eoline*).

#### ITALIAN.

ARNOLDIE (G.) & Cie, 37 Via Pavlo da Cannobis, Milan

PETROLI D'ITALIA (Soc.) (*Italia*), 12 Via Andegari, Milan

PETROLIO (Soc. Ital. Americana), 76 Piazza Cinque Lampa, Genoa

#### ROUMANIAN.

AQUILA, Franco-Romana, Bucharest

ETOILE ROUMAINE, Bucharest

#### RUSSIAN.

KAISER (B.), Baku

NANOYAN & Cie, Batum

PITOEFF & Cie, Taflis

SCHIBAEFF & Cie, Baku

TER-AKOPOFF, 3 Place Isaac, St. Petersburg

#### SPANISH.

CATASUS & Co., 1 Colon, Barcelona

DESMARIS FRERES, 8 Rue Claire, Madrid

FOURCADEY PROVOT, 8 Calle de Fernafior, Madrid

VILELLA, Tarragona

#### SWISS.

HUILES MINERALES (SOCIETE SUISSE POUR LE COMMERCE DE), Route de Frontenex, Geneva

#### U.S.A.

ELLIS & Co., 11 Broadway, New York

PETROLEUM OIL TRUST, 27 William Street, New York

PURE OIL Co., 11 William Street, New York

## PROPELLERS.

#### BELGIAN.

WANSON (Maurice), 10 Rue Jean Spas, Brussels

#### BRITISH.

AVRO. (See Roe (A.V.) & Co.)

BENEY (R.) & Co., 7 Carlisle Street, Oxford Street, London, W.

**BLACKBURN (B.)**, Balm Road, Leeds

**BRITISH & COLONIAL AEROPLANE Co., Ltd.**, Bristol

BROWN Bros., Ltd., 22-34 Great Eastern Street, London, E.C.

CLARKE (T. W. K.) & Co., 26 Clarges Street, London, W.

DOVER AVIATION Co., Ltd., Dover (*Normale*)

GENERAL AVIATION CONTRACTORS Ltd., 30 Regent Street, London, S.W. (*Rapid*)

GRAHAME-WHITE (C.) & Co., Ltd., 1 Albemarle Street, Piccadilly, London, W.

HANDLEY PAGE, Ltd., 72 Victoria Street, London, S.W.

HARRIS & SAMUELS, 10 Dean Street, Oxford Street, London, W.

HOLLAND & HOLLAND, 479-483 Oxford Street, London, W.

LUDWIG LOEWE & Co., Ltd., 30-32 Farringdon Road, London, E.C.

MADISON DYNAMO ELECTRIC Co., Littleover, Derby

MACFIE (R.F.) & Co., Norwich Union Chambers, St. James' Street, London, W.

MOTOR ACCESSORIES Co., 55 Great Marlborough Street, London, W.

**PIGGOTT (Bros.) & Co., Ltd.**, 220-222-224 Bishopsgate, London, E.C.

ROE (A. V.) & Co., Brownsfield Mills, Manchester

SMITH & DOREY (G. H. & W. H.), Ltd., 14a Great Marlborough Street, London, W.

SPENCER & SONS (C. G.), 56a, Highbury Grove, London, N.

TWINING AEROPLANE Co., 29b Grosvenor Road, Hanwell, London, W.

WEBB, PEET & Co., Gloucester

W.B.G. (See Wilson, Bros. & Gibson)

WILSON (Bros.) & GIBSON, Twickenham (*W. B. G.*)

WRIGHT (Howard T.) (See Howard Wright)

WOOD (T.B.), Littleover Works, Derby

#### FRENCH.



APPAREILS AÉRIENS (Société de Construction D'), 36 Rue du Bois, Levallois-Perret  
AVIA (Société Générale D'Industrie Aéronautique), 62 Rue de Provence, Paris  
BAUDOT & PAZ, 22 Avenue de la Grande Armée, Paris  
BAUJARD (Claude), 309, Faubourg Sainte-Antoine, Paris (*Eola*)  
BREQUET (Louis), Boulevard Vauban, Douai  
CHAUVIÈRE (L.), 52 Rue Servan, Paris (*Intégrale*)  
CHERVILLE (M.), 6 Place de l'Odéon, Paris.  
DOREY (W.H.), 14 Rue Torricelli, Paris  
DURVILLE (P. N. G.), 38 Rue Jouffroy, Paris.  
EOLA (*See* Baugard)  
ESNAULT-PELTERIE (ETABLISSEMENTS), 149 Rue de Silly, Billancourt (*R.E.P.*)  
GODARD (Louis), 170 Rue Legendre, Paris  
HELICE (E.T.M.), PARIS INGENIEUR, 17 Rue Cassette, Paris  
KAPFERER (M.), 2 Avenue de Messine, Paris (*Aero-propulser*). (*A.P.*)  
KOECHLIN (P.), 45 Rue Denfert-Rochereau, Boulogne, S.  
LABANHIE ET RUTHER, 2 Rue de Seine, Suresnes  
LETORD & NIEPCE, 15 Rue Paira et 23 Terre-Neuve, Mendon (*Dargent*)  
LIORE, 4 *bis*, Rue de Cormeille, Levallois-Perret  
PANHARD & LEVASSOR (Société Des Anciens Établissements), 19 Avenue D'Ivry, Paris  
PASSERAT & RADIQUET (Établissements), 127 Rue Michel-Bigot, Paris (*Progressive*)  
PELLIAT (L.), 15 Grand Rue, Asnières (*Rationnelle*)  
PEYZARET-PARANT, 4 *bis*, Rue Louis-Philippe, Neuilly-sur-Seine, Paris  
RATMANOFF, 9 Rue Eugène-Eichenberger, Piteaux (*Normale*)  
RÉGY FRERES (Les Fils de), 120 et 122 Rue de Javel, Paris  
R. E. P. (*See* Esnault-Pelterie)  
ROSSEL-PEUGOT, Sochaux, près Montbéliard (Doubs) (Société Anonyme des Constructions  
Aériennes)  
TELLIER (CHANTIERS), Juvisy  
THOMAS, 5 Rue des Tanneries, Paris  
VINOGRADOW (MICHEL), 83 Quai d'Issy, Issy-les-Moutisn  
VOISIN, 34 Quai du Point-du-Jour, Billancourt  
VUITTON (LOUIS), 1 Rue Scribe, Paris

GERMAN.

ERSTE-DEUTSCHE AUTOMOBIL-FACHSCHULE, Mainz  
FICHTEL & SACHS, Schweinfurt A.M.  
PARSEVAL, Bitterfield  
SCHLOTTER (G.A.), Dresden-A. 16

U.S.A.

AERIAL PROPELLER Co., White Plains, New York  
AMERICAN PROPELLER Co., Washington, D.C. (*Paragon*)  
BRAUNER (P.) & Co., 335-339 East 102nd Street, New York

CRAFTSMAN PERFECT PROPELLERS, 626 Erie Avenue, Chicago  
DETROIT AERONAUTIC CONSTRUCTION Co., 306 Holcomb Avenue, Detroit, Michigan  
DUQUET (L. G.), 107 W. 36th Street, New York  
GREEN (Rurl. H.), 515 Delta Buildings, Los Angeles, Cal.  
HOLBROOK AERO. SUPPLY Co., Joplin, Mo.  
REQUA-GIBSON, 225 West 49th Street, New York  
STUPAR (M.), 9626 Erie Avenue, Chicago  
WILCOX PROPELLER, Box 181 Madison Square, New York

## RADIATORS.

### BELGIAN.

TOLÉRIE AUTOMOBILE BELGE, 17 Rue des Boyards, Liège

### BRITISH.

ALBANY MANUFACTURING Co., Willesden Junction, London, N.W.  
COVENTRY MOTOR FITTING Co., Far Gasford Street, Coventry  
DOHERTY MOTOR COMPONENTS, Ltd., Coventry  
LAMPLOUGH & Son, Ltd., Willesden Junction, London, N.W. (*Lamplough-Albany*)  
MOTOR RADIATOR MANUFACTURING Co.:—  
    Parkside, Coventry  
    23 Tanner Street, Bermondsey, London, S.E.  
SPIRAL TUBE & COMPONENTS Co., Caledonia Street, King's Cross, London, N.

### FRENCH.

ARQUEMBOURG (Louis), 157 Faubourg, Saint-Denis, Paris  
BANNEVILLE, 119 Rue Saint-Maur, Paris  
BARDOU (E.), 150 Rue Victor-Hugo, Levallois-Perret  
BAUDIER (Ch.), 30-32 Rue Baudin, Levallois-Perret  
BISIAUX, 11 Rue Petit, Paris  
BONFILS, 37 Avenue de Saint-Mandé, Paris  
BRACHTEN ET GALLAY, Bellegarde  
CHAMPESME, 5 Rue La Vieuville, Paris  
CHAROY (G.) Et Cie, 5 Boulevard Voltaire, Paris  
CHAUSSON Frères, 27 Rue Malakoff, Asnieres  
CHIROL & Cie, 53 Rue de Lorraine, Levallois-Perret  
CHOUBERSKY (Société Anonyme des Etablissements), 20 Rue Félicien-David, Paris  
COCHAUX (Emile), Deville  
DARBILLY (J.), 198 Boulevard Pereire, Paris  
DESNOYERS Freres, 116 Boulevard Richard-Lenoir, Paris  
DURAND, GIROUX & Cie, 5 Rue Saint-Marri, Paris  
ELECTRIC ACETYLENE (L.), 52 Rue Balay, Saint-Etienne  
ELOY (Lucien), Rue Louis Soyer, Villemonble  
ENTREPOT METALLURGIGUE (L.), 5 Passage de l'Industrie, Paris  
ESTABLIE Freres et Louis Establie, 11 Quai de Valmy, Paris  
FREES (De), 19 Rue de Recroy, Paris  
FUREST (G.) et Cie, 32 Boulevard Henri-IV., Paris  
GAY ET BOURGOENS, 53 Rue Louis-Blanc, Lyon  
GOUDARD MENNESSON, 119 Rue de Montreuil, Paris  
GRIMMEISEN (Ch. & G.), 5 et 7 Passage Piver, 92 Faubourg du Temple, Paris

GRENIER & MERCIER (SOCIÉTÉ ANONYME DES ETABLISSEMENTS), 8 Avenue de Bouvines, Paris  
GROUVELLE, ARQUEMBOURG ET Cie, Rue du Moulin-Vert, Paris (*Arécal*)  
LAEIS & Cie, 86 Rue de Villiers, Levallois-Perret  
LAMBERT (P.) et Cie  
    109 Rue de Paris, Puteaux  
    36 Rue Vitruve, Paris  
LE BRUN ET LECOMTE, 14 Rue Victor-Hugo, Puteaux  
LIOTARD Freres, 22 Rue de Lorraine, Paris  
LORTHIOY (E.), 9 Avenue du Clos, St. Maur-les-Fosses  
MARCHAL (A.), 9 Rue de l'Hotel-de-Ville, Neuilly-sur-Seine  
MONTBARBON (Société Anonyme), 47 bis, Rue de Villiers, Neuilly-sur-Seine (*Loziano*)  
MONNET & MOYNE, 11 Rue Torricelli, Paris  
MOREUX (G.) & Cie, 24 Rue Fromont, Lyon (*G.M.*)  
OSSANT Freres, 29 Rue Arago, Puteaux  
PRINI ET BERTHAUD, 23 Rue Servan, Paris  
PROUX, Boulevard Pont-Ochard, Poitiers  
RADIATORS ET RÉFRIGÉRATEURS (Société des), 54 Rue de la Chapelle, Saint-Ouen (*Sans Soudure*)  
SCHLEY (A.) Et Cie, 204 Rue Saint-Maur (*Loyal*)  
SERROVAL (De) Et MASSE, 17 Rue David, Lyon  
TOPOLSKI, 53 Boulevard de Belleville, Paris  
VIGNEAUX, 5 Rue Bacon, Paris

### ITALIAN.

ALGOSTINO, BALAGNA, MAGNINO & Cia, 107 Madama Cristina, Turin  
BONO & Co. (Societa Italiana), 54 Corso Porta, Vittoria, Milan  
GALIMBERTI, 20 Via Senato, Milan

### SPANISH.

COROMINAS (Ricardo), 45 Torrente de la Olla, Barcelona

### SWISS.

HENNEBERG & DEY, à la Jonction, Geneve-Frontenex

### U.S.A.

AERIAL NAVIGATION Co., of AMERICA, Girard, Kansas (*Call.*)  
EL ARCO Co., 6 East 31st Street, New York  
KINSEY MFTG. Co., Dayton, Ohio  
LIVINGSTONE RADIATOR Co., 6 East 31st Street, New York  
LONG MFTG. Co., 1430 Michigan Avenue, Chicago  
MAYO RADIATOR Co., New Haven, Con.  
McCORD & Co., 1400 and 1440 Old Colony Buildings, Chicago

MOTOR COMPONENTS MFTG. Co., 119 E. Walnut Street, Des Moines, Iowa  
ROME-TURNEY RADIATOR Co., East 31st Street, New York  
WOLVERINE RADIATOR Co., 124 Sidney Avenue, Detroit, Mich.

## ALPHABETICAL INDEX OF AEROPLANES.

Abbreviations:—Aust=Austro-Hungarian; Bel=Belgian; Brit.=British; Ger.=German;  
Ital.=Italian; Jap.=Japanese; Rou.=Roumanian; Rus.=Russian.

### A

Aeros., Brit., [37](#)  
Aerial Exhibition Co., U.S.A., [207](#)  
Aerial Yacht Co., U.S.A., [207](#)  
Aircraft Factory "B. E." Brit., [37](#)  
Aircraft Manufacturing Co., Brit., [37](#)  
Albatross, Ger., [131](#)  
American Aeroplane Supply House, U.S.A., [207](#)  
Antoni, Ital., [172](#)  
Ask, Swede, [197](#)  
Asteria, Ital., [172](#)  
Aviatik, Ger., [133](#)  
Avro, Brit., [38](#)

### B

Baldwin, U.S.A., [208](#)  
Bayard-Clement, [87](#)  
Behueghe, Bel., [28](#)  
Benoist, U.S.A., [209](#)  
Blackburn, Brit., [40](#)  
Blair Atholl, Brit., [42](#)  
Bleriot, French, [81](#)  
Boland, U.S.A., [209](#)  
Borel, French, [83](#)  
Bracke, A. Bel., [28](#)  
Breguet, French, [84](#)  
Bristol, Brit., [42](#)  
Bronislowski, Rus., [190](#)  
Burgess, U.S.A., [210](#)  
Burgess-Curtis, U.S.A., [211](#)  
Burgess-Wright, U.S.A., [210](#)

### C

Calderara, Ital., [173](#)  
Caproni, Ital., [174](#)

Caudron, French, [66](#)  
Chiribiri, Ital., [174](#)  
Christmas, U.S.A., [212](#)  
Clement Bayard, French, [87](#)  
Cody, Brit., [45](#)  
Cooke, U.S.A., [212](#)  
Coventry Ordnance Co., Brit., [46](#)  
Curtiss, U.S.A., [213](#)

## D

Dahlbeck, Swede., [197](#)  
D'Artois, French, [88](#)  
De Brouckere, Dutch, [28](#)  
De la Hault, Bel., [28](#)  
Deperdussin, French, [89](#)  
Donnet-Leveque, French, [90](#)  
Doutre, French, [91](#)  
Dorner, Ger., [134](#)  
Dunne, Brit., [47](#)  
Dux, Rus., [190](#)

## E

Etrich, Ger., [134](#)  
Etrich, Aust., [18](#)  
Euler, Ger., [135](#)  
Ewen, Brit., [48](#)

## F

Farman, H., French, [92](#)  
Farman, M., French, [92](#)  
Ferguson, Brit., [48](#)  
Fokker, Dutch, [72](#)  
Fokker, Ger., [136](#)  
Friuli, Ital., [175](#)

## G

Gallaudet, U.S.A., [214](#)  
Geltouchow, Rus., [190](#)  
Goedecker, Ger., [138](#)  
Goupy, French, [94](#)  
Grade, Ger., [138](#)

Grahame-White, Brit., [49](#)  
Grandjean, Swiss., [199](#)  
Guidoni, Ital., [175](#)

## H

Handley Page, Brit., [50](#)  
Hanriot, French, [95](#)  
Hansa Taube, Ger., [138](#)  
Hanuschke, Ger., [140](#)  
Harlan, Ger., [139](#)  
Harel, Bel., [28](#)  
Howard-Flanders, Brit., [51](#)

## I

Internat. Ae. Con. Co., U.S.A., [217](#)

## J

Jatho, Ger., [140](#)  
Jeannin, Ger., [141](#)

## K

Kahnt, Ger., [141](#)  
Kennedy, Rus., [190](#)  
Kirkham, U.S.A., [215](#)  
Kondor, Ger., [142](#)  
Kuhlstein, Ger., [142](#)

## L

Lake Flying Co., Brit., [53](#)  
Loening, U.S.A., [215](#)  
Lohner-Daimler, Aust., [19](#)

## M

Mars, Ger., [143](#)  
Martinsyde, Brit., [53](#)  
McCurdy, Canada, [64](#)  
Mercep, Aust., [20](#)  
Monnier-Harper, Dutch, [72](#)  
Morane-Saulnier, French, [96](#)

Moreau, French, [97](#)  
Mrozinski, Ger., [143](#)

## N

Narahara, Jap., [181](#)  
Nieuport, French, [98](#)  
Nyrop, Swede, [197](#)

## O

Oertz, Ger., [144](#)  
Otto, Ger., [144](#)

## P

Paulhan-Curtiss, French, [99](#)  
Pega-Emich, Ger., [145](#)  
Piggott, Brit., [54](#)  
Pippart-Noll, Ger., [145](#)  
Pischoff, French, [99](#)

## R

Radley-England, Brit., [54](#)  
Rep, French, [100](#)  
Rodjestveisky, Rus., [190](#)  
Rumpler, Ger., [146](#)  
Ruth-Rohde, Ger., [147](#)

## S

Sanchez Besa, French, [101](#)  
Savary, French, [102](#)  
Schelies, Ger., [147](#)  
Schultze, Ger., [148](#)  
Sellers, U.S.A., [215](#)  
Short, Brit., [54](#)  
Sigismund, Ger., [148](#)  
Sloan, French, [103](#)  
Sloane, U.S.A., [215](#)  
Sommer, French, [104](#)  
Sopwith, Brit., [57](#)

Taddeoli, Swiss, [199](#)  
Thomas, U.S.A., [216](#)  
Tokogawa, Jap., [181](#)  
Train, French, [105](#)  
Tubavion, French, [105](#)

## T

## U

Union Flugzeugwerke, Ger., [149](#)

## V

Van den Burg, Dutch, [72](#)  
Vickers, Brit., [58](#)  
Vinet, French, [106](#)  
Vlaiclu, Rou., [187](#)  
Voisin, French, [107](#)  
Vreedenburgh, Dutch, [72](#)

## W

Warchalowski, Aust., [21](#)  
Washington Co., U.S.A., [217](#)  
Wetterwald, Swiss, [199](#)  
White, Brit., [59](#)  
Whitehead, Aust., [21](#)  
Williams, Bel., [28](#)  
Wittemann, U.S.A., [217](#)  
Wright, Ger., [150](#)  
Wright, U.S.A., [218-219](#)

## Z

Ziegler, Ger., [150](#)  
Ziegler, Aust., [21](#)  
Zodiac, French, [108](#)

## ALPHABETICAL INDEX OF DIRIGIBLES.

- Adjutant Reau, French, [109 113](#)  
Adjutant Re Vincennot, French, [109 113](#)  
Astra, French, [111](#)  
Astra Torres, British, [60](#)  
Astra Torres, French, [115](#)  
Astra III, Russian, [193](#)  
Astra Transaerien-Ville de Pau-Ville de Lucerne, French, [111](#)  
Astra Ville de Pau, French, [111](#)  
Ausonia, Italian, [179](#)  
Beta, British, [60](#)  
Boemcher II, Austrian, [23](#)  
Capitaine Ferber, French, [109](#)  
Capitan Maréchal, French, [109](#)  
Citta di Milano, Italian, [177](#)  
Clement Bayard VI. French, [109](#)  
Clement Bayard, Russian, [191](#)  
Colonel Renard, French, [109 112](#)  
Commandant Coutelle, French, [109](#)  
Delta, British, [60](#)  
Deutschland, German, [151](#)  
Dupuy-de-Lôme, French, [117](#)  
Eclaireur Conté, French, [109 114](#)  
Epsilon, British, [60](#)  
Ersatz Deutschland, German, [166](#)  
Espana, Spanish, [195](#)  
Fleurus, French, [109](#)  
Forszmann, Russian, [191](#)  
Gamma, British, [60](#)  
Hausa, German, [167](#)  
Italia, Italian, [179](#)  
Jastreb, Russian, [191](#)  
Kommissiony, Russian, [191](#)  
Korting-Wimpassing, Austrian, [24](#)  
La Belgique II & III, Belgian, [29 30](#)  
Lebaudy-Juillot 6, Austrian, [23](#)  
Lebedj, Russian, [191](#)  
Leonardo da Vinci, Italian, [179](#)  
Le Temps, French, [109](#)  
Liberté, French, [109](#)  
Lieut. Chaure, French, [109 113](#)  
L I, German, [151](#)  
L II, German, [151](#)  
Le Temps, French, [122](#)  
Liberte, French, [109](#)  
M I, German, [154](#)  
M II, German, [154](#)  
M III, German, [154](#)  
M IV, German, [155](#)  
Mannsbarth, Austrian, [24](#)  
P I, German, [151](#)  
P II *Ersatz*, German, [151](#)  
P III, German, [151](#)  
P IV, German, [151](#)  
P. L I, German, [151](#)  
P. L 9, German, [151](#)  
P. L XII, German, [151](#)  
P. L 10, German, [151](#)  
Parseval, Austrian, [25](#)  
Parseval, British, [160](#)  
Parseval, German, [157, 158, 159, 160, 161](#)  
Parseval, Italian, [177](#)  
Parseval, Japanese, [182](#)  
Ruthenberg II, III, German, [162](#)  
Sachsen, German, [151](#)  
Schütte-Lanz I & II, German, [163](#)  
S. L I, German, [151](#)  
S. L II, German, [151](#)  
Selle de Beauchamp, French, [109](#)  
Spiess, French, [109](#)  
Stollwerck, German, [151](#)  
Suchard, German, [163](#)  
S. I. II, German, [151](#)  
Suchard, German, [151](#)  
Torres-Quevedo II, Spanish, [195](#)  
Transaerienne II, French, [113](#)  
Usuelli, Italian, [179](#)  
Vanniman, [10d](#)  
Viktoria Luise, German, [166](#)  
Ville de Bruxelles, Belgian, [30](#)  
Ville de Lucerne, French, [111](#)  
Ville de Paris, French, [110](#)  
Willows, British, [60](#)  
Yamada, Japanese, [182](#)  
Z I, German, [151](#)

Z II, German, [151](#)  
Z III, German, [151](#)  
Z IV, German, [151](#)  
Zeppelin, German, [164](#), [165](#) [166](#)  
Zodiac III, French, [120](#)  
Zodiac XII, French, [125](#)

Contractors to the majority of leading governments of the world.  
The Celebrated

Contractors to h. m. war office and admiralty.  
"Bristol"  
Aeroplanes.

LEARN TO FLY

AT THE  
"BRISTOL SCHOOLS"  
AT SALISBURY PLAIN and BROOKLANDS.

TUITION is given on all the latest type "BRISTOL" MACHINES, including:

- 80 H.P. MILITARY MONOPLANES.
- 50 H.P. MILITARY MONOPLANES.
- 50 H.P. SIDE-BY-SIDE SCHOOL MONOPLANES.
- TRACTOR BIPLANES & SCHOOL BIPLANES.

SPECIAL FACILITIES AND REDUCED FEES TO SERVICE OFFICERS.  
WRITE FOR INFORMATION:

THE BRITISH & COLONIAL AEROPLANE Co., Ltd.,  
FILTON, BRISTOL, ENG.

"EMPYREAN" POLICY

INSURING PILOTS OF AEROPLANES AGAINST

FIRE & EXPLOSION.  
THIRD PARTY CLAIMS.

DAMAGE DURING TRANSIT.  
INJURY TO EMPLOYEES.

ACCIDENTAL DAMAGE.  
INJURY TO PILOTS.



CAR & GENERAL  
INSURANCE CORPORATION, LIMITED.

LIQUID ASSETS nearly £200,000.

NET INCOME, £290,000.

HEAD OFFICE:  
1, QUEEN VICTORIA STREET (BANK), LONDON, E.C.

BRANCH OFFICES.

ABERDEEN—245, Union Street  
BEDFORD—17, St. Paul's Square  
BIRMINGHAM—Prince's Chambers, 6 Corporation Street  
BRADFORD—Prudential Buildings, Ivegate  
BRIGHTON—18, Queen's Road  
BRISTOL—West India House, Bristol Bridge  
CARDIFF—1, Bank Buildings (Ground Floor), St. Mary St.  
CROYDON—52, North End  
DUBLIN—33, Dawson Street  
DUNDEE—14, Barrack Street  
EALING—19, The Broadway  
EDINBURGH—87, Shandwick Place  
EXETER—28, Gandy Street  
GLASGOW—163, West George Street  
HANLEY—P.O. Chambers, Crown Bank  
HULL—Walton Chambers, 48 Jameson Street  
IPSWICH—St Mildred's Chambers, Cornhill  
KENT—137-138, High Street, Bromley  
LEEDS—Yorkshire Post Chambers, Albion Street  
LEICESTER—1, Horsefair Street  
LIVERPOOL—2, South John Street (Lord Street Corner)  
LONDON, N.E.—124, High Street, Shoreditch  
LONDON MID.—379, Strand, W.C.  
LONDON S.—222, Great Dover Street, S.E.  
LONDON S.W.—222, Great Dover Street, S.E.  
LONDON W.—1, Albemarle Street, Piccadilly  
MANCHESTER—1, Princess Street, Albert Square  
NEWCASTLE—Pearl Buildings, Northumberland Street  
NORTHAMPTON—Market Square  
NOTTINGHAM—Westminster Buildings, Theatre Square  
PLYMOUTH—90, Old Town Street  
READING—Broadway Buildings, Station Road  
RICHMOND—26, Hill Street  
SHEFFIELD—King's Chambers, Angel St.  
SOUTHAMPTON—Blenheim Chambers, Above Bar (the Junction)

WE ARE THE PIONEERS AND LEADERS IN ALL INSURANCE FACILITIES FOR  
MOTORISTS.

MORE THAN MONEY INDEMNITY.

Our 35 Branch Offices in charge of skilled Salaried Official, our Engineering Staff wholly in the service of the Corporation, our expert Claims Staff everywhere, and the fact that we are the Pioneers and Originators of all the Insurance Facilities now enjoyed by Motorists, enable us to offer something more than money indemnity; we can, and do, protect a motorist in a thousand ways, unobtainable elsewhere, by means of our experience and splendid organisation, and yet we only charge **competitive rates of Premiums.**

ALPHABETICAL LIST OF ADVERTISERS.

	PAGE
Anglo-American Oil Co., Ltd.	<a href="#">xii</a>
Barbet-Massin, Popelin & Cie ( <i>France</i> )	<a href="#">xi</a>
Blackburn Aeroplane Co.	<a href="#">vii</a>
Branger ( <i>France</i> )	<a href="#">xiii</a>
Bray, Gibb & Co., Ltd.	<a href="#">ix</a>
British & Colonial Aeroplane Co., Ltd.	<a href="#">inside front cover</a>
Burberrys'	<a href="#">vii</a>
Car & General Insurance Corporation, Ltd.	<a href="#">ii</a>
Coan, Robert W.	<a href="#">vi</a>
Continental Tyre & Rubber Co., (Gt. Britain) Ltd.	<a href="#">vii</a>
Cox, G.H. & Co., Ltd.	<a href="#">vi</a>
Crosby Lockwood & Son	<a href="#">vi</a>
Doutre, Appareils d'Aviation ( <i>France</i> )	<a href="#">v</a>
Drummond Bros., Ltd.	<a href="#">viii</a>
Eisemann Magneto Co.	<a href="#">xii</a>
Fighting Ships	<a href="#">xiv</a>
"Geographia," Ltd.	<a href="#">vi</a>
Hasler Co., The	<a href="#">viii</a>
Howard-Flanders, L., Ltd.	<a href="#">xi</a>
Hoyt Metal Company of Great Britain, Ltd.	<a href="#">vi</a>
Jones Brothers, Ltd.	<a href="#">xi</a>
Kemp Machine Works (U.S.A.)	<a href="#">xiii</a>
Knowles Oxygen Co., Ltd.	<a href="#">vii</a>
Mallinson, Wm. & Sons, Ltd.	<a href="#">ix</a>
Martin & Handasyde	<a href="#">x</a>
Mea Magneto Co., Ltd.	<a href="#">xiii</a>
Owen, Joseph & Sons, Ltd.	<a href="#">xi</a>
Piggott Bros. & Co., Ltd.	<a href="#">xi</a>
Pratt's Motor Spirit	<a href="#">xii</a>
Rogers Brothers	<a href="#">xi</a> & <a href="#">xiv</a>
Sampson Low, Marston & Co., Ltd.	<a href="#">xiv</a>
Sopwith Aviation Co.	<a href="#">ix</a>
Stanley, Popplewell & Co.	<a href="#">vii</a>
Thorn & Hoddle Acetylene Co., Ltd.	<a href="#">viii</a>
Valdenaire, H., Adenet & Cie ( <i>France</i> ).	<a href="#">xiii</a>



Vandervell, C.A. & Co.  
Vickers, Ltd.  
White & Poppe, Ltd.  
Whiteman & Moss, Ltd.  
Wolseley Tool & Motor Car Co., Ltd.

[viii](#)  
[xv](#)  
[vii](#)  
[viii](#)  
[vi](#)

## CLASSIFIED INDEX OF ADVERTISERS.

	PAGE
Accessories.	
Anglo-American Oil Co., Ltd.	<a href="#">xii</a>
Barbet-Massin, Popelin & Cie ( <i>France</i> )	<a href="#">xi</a>
Coan, Robert W.	<a href="#">vi</a>
Eisemann Magneto Co.	<a href="#">xii</a>
"Geographia," Ltd.	<a href="#">vi</a>
Hasler Co., The	<a href="#">viii</a>
Jones Brothers, Ltd.	<a href="#">xi</a>
Mallinson, Wm. & Sons, Ltd.	<a href="#">ix</a>
Mea Magneto Co., Ltd.	<a href="#">xiii</a>
Owen, Joseph & Sons, Ltd.	<a href="#">xi</a>
Piggott Brothers & Co., Ltd.	<a href="#">xi</a>
Pratt's Motor Spirit	<a href="#">xii</a>
Rogers Brothers	<a href="#">xi</a> & <a href="#">xiv</a>
Valdenaire, H., Adenet & Cie ( <i>France</i> )	<a href="#">xiii</a>
Vandervell, C.A., & Co.	<a href="#">viii</a>
White & Poppe, Ltd.	<a href="#">vii</a>
Whiteman & Moss, Ltd.	<a href="#">viii</a>
Aeroplane Builders.	
Blackburn Aeroplane Co.	<a href="#">vii</a>
British & Colonial Aeroplane Co. Ltd.,	<a href="#">inside front cover</a>
Doutre, Appareils d'Aviation ( <i>France</i> )	<a href="#">v</a>
Howard-Flanders, L., Ltd.	<a href="#">xi</a>
Martin & Handasyde	<a href="#">x</a>
Sopwith Aviation Co.	<a href="#">ix</a>
Vickers, Ltd.	<a href="#">xv</a>
Aluminium.	
Coan, Robert W.	<a href="#">vi</a>
Aviation Garments.	
Burberrys'	<a href="#">vii</a>
Bearings.	
Hoyt Metal Co., Ltd.	<a href="#">vi</a>
Castings.	
Coan, Robert W.	<a href="#">vi</a>
Carburettors.	
White & Poppe, Ltd.	<a href="#">vii</a>

Dynamos.	
Eisemann Magneto Co.	<a href="#">xii</a>
Electric Lighting.	
Vandervell, C.A., & Co.	<a href="#">viii</a>
Engines.	
Kemp Machine Works (U.S.A.)	<a href="#">xiii</a>
Wolseley Tool & Motor Car Co., Ltd.	<a href="#">vi</a>
Fabrics.	
Barbet-Massin, Poplin & Cie ( <i>France</i> )	<a href="#">xi</a>
Continental Tyre & Rubber Co. (Gt. Britain) Ltd.	<a href="#">vii</a>
Jones Brothers, Ltd.	<a href="#">xi</a>
Rogers Brothers	<a href="#">xi</a> & <a href="#">xiv</a>
Valdenaire, H., Adenet & Cie ( <i>France</i> )	<a href="#">xiii</a>
Flying Schools.	
Blackburn Aeroplane Co.	<a href="#">vii</a>
British & Colonial Aeroplane Co. Ltd., Doutre, Appareils d'Aviation ( <i>France</i> )	<a href="#">inside front cover</a>
Howard-Flanders, L., Ltd.	<a href="#">v</a>
Martin & Handasyde	<a href="#">x</a>
Sopwith Aviation Co.	<a href="#">ix</a>
Vickers, Ltd.	<a href="#">xv</a>
Garage.	
Cox, G.H. & Co., Ltd.	<a href="#">vi</a>
Hangar and Shed Builders.	
Piggott Bros. & Co., Ltd.	<a href="#">xi</a>
Hardwoods.	
Mallinson, William & Sons	<a href="#">ix</a>
Owen, Joseph & Sons, Ltd.	<a href="#">xi</a>
Hydrogen.	
Knowles Oxygen Co.	<a href="#">vii</a>
Indicators.	
Hasler Co., The	<a href="#">viii</a>
Insurance.	
Bray, Gibb & Co., Ltd.	<a href="#">ix</a>
Car & General Insurance Corporation, Ltd.	<a href="#">ii</a>
Life Saving Vests.	
Rogers Brothers	<a href="#">xi</a> & <a href="#">xiv</a>
Machine Tools.	
Drummond Bros. Ltd.	<a href="#">viii</a>

Magnetos.	
Eisemann Magneto Co.	<a href="#">xii</a>
Mea Magneto Co., Ltd.	<a href="#">xiii</a>
Maps (specially designed).	
"Geographia," Ltd.	<a href="#">vi</a>
Motor Spirit.	
Anglo-American Oil Co., Ltd.	<a href="#">xii</a>
Pratt's Motor Spirit	<a href="#">xii</a>
Patent Agents.	
Stanley, Popplewell & Co.	<a href="#">vii</a>
Photographer.	
Branger ( <i>France</i> )	<a href="#">xiii</a>
Publishers.	
Crosby Lockwood & Son	<a href="#">vi</a>
"Geographia," Ltd.	<a href="#">vi</a>
Sampson Low, Marston & Co., Ltd.	<a href="#">xiv</a>
Stabilisateurs.	
Doutre, Appareils d'Aviation	<a href="#">v</a>
Tuition.	
Blackburn Aeroplane Co.	<a href="#">vii</a>
British & Colonial Aeroplane Co. Ltd., Doutre, Appareils d'Aviation ( <i>France</i> )	<a href="#">inside front cover</a>
Howard-Flanders, L., Ltd.	<a href="#">v</a>
Martin & Handasyde	<a href="#">xi</a>
Sopwith Aviation Co.	<a href="#">ix</a>
Vickers, Ltd.	<a href="#">xv</a>
Welding.	
Thorn & Hoddle Acetylene Co., Ltd.	<a href="#">viii</a>

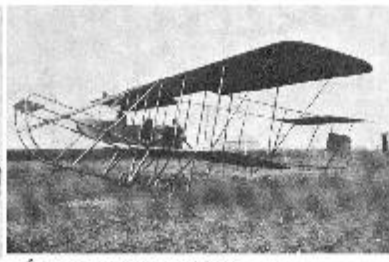
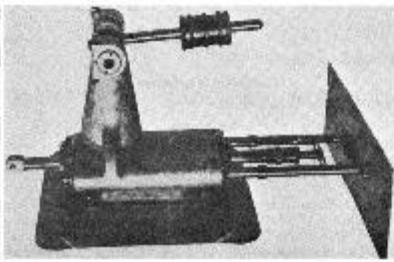
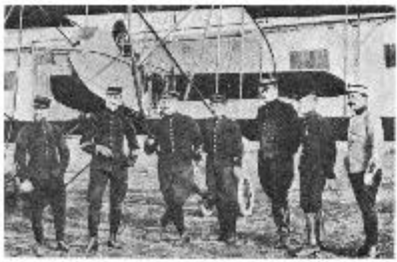

ÉCOLE MILITAIRE DE CORBEAULIEU. STABILISATEUR DOUTRE.

AÉROPLANE DOUTRE.

### BIPLANS TRIPLACES

les mieux construits, les plus surs et automatiquement stabilisés

*ÉCOLE CIVILE ET MILITAIRE Aerodrome de Corbeaulieu près Compiègne France.*

### Sté des APPAREILS d'AVIATION DOUTRE

Fournisseurs des armées Françaises et Étrangères.

*LE SUEL STABILISATEUR AUTOMATIQUE PESANT TOUT ÉQUIPÉ DOUZE À QUINZE KILOGS  
ET AYANT FAIT SES PREUVES PAR PLUS DE DEUX MILLE VOLS SANS ACCIDENT. APPLICABLE  
À TOUS LES AÉROPLANES ET HYDROAÉROPLANES.*

*SÉCURITÉ ABSOLUE, VOL PAR TOUS LES TEMPS.*

CATALOGUE FRANCO SUR DEMANDE - FETTERER DIRECTEUR GÉNÉRAL. 58 RUE  
TAITBOUT. PARIS. TÉLÉPH CENTRAL 37-53.

Aluminium Castings  
FOR MOTORS OF EVERY DESCRIPTION,  
2 H.P. to 200 H.P.

CAST ALUMINIUM MOTOR  
NUMBER PLATES  
(Regulation Size).

BRIGHT POLISHED FIGURES AND BEADED EDGES, WITH DEAD BLACK BACK  
GROUND.

LA.1742  
R.5077

Send for particulars of my new COMBINED TOURING PLATE (Reg.)

Telegrams: "KRANKASES," ISLING, LONDON. Telephones: 3846 City. 4879 Central.

Coan  
Casts  
Clean  
Crank  
Cases



ON ADMIRALTY AND WAR OFFICE LISTS.

**ROBERT W. COAN,**

THE ALUMINIUM FOUNDRY,  
219, GOSWELL ROAD, E.C.

**WOLSELEY**

LIGHT

Aero Motors

60 H.P. and 120 H.P. (water cooled).

60-80 H.P. (combined air and water cooled.)

Catalogue free on application to  
THE WOLSELEY TOOL AND MOTOR CAR Co., Ltd.

Proprietors: VICKERS, Limited, ADDERLEY PARK, BIRMINGHAM.

"Geographia," Ltd.  
33, STRAND, W.C.

SPECIALISTS IN AVIATION ACCESSORIES.

Alexander Cross - ANTI-DRIFT COMPASS

Alexander Cross - BEARING FINDER

Alexander Cross - MAP CASE

"GEOGRAPHIA" BAROGRAPHS and HEIGHT  
RECORDERS.

MAPS FOR AVIATORS DRAWN TO ORDER.

AVIATION MAPS FROM AERODROME TO AERODROME ALWAYS IN STOCK.

ASK FOR ILLUSTRATED PRICE LIST.

Telegraphic Address:—"Geografo, London."

Telephone 4965 City.

G. H. Cox & Co., Ltd.

CASTLE ROAD,  
SOUTHSEA,  
:: HANTS. ::

LARGEST GARAGE IN ::  
THE SOUTH OF ENGLAND.

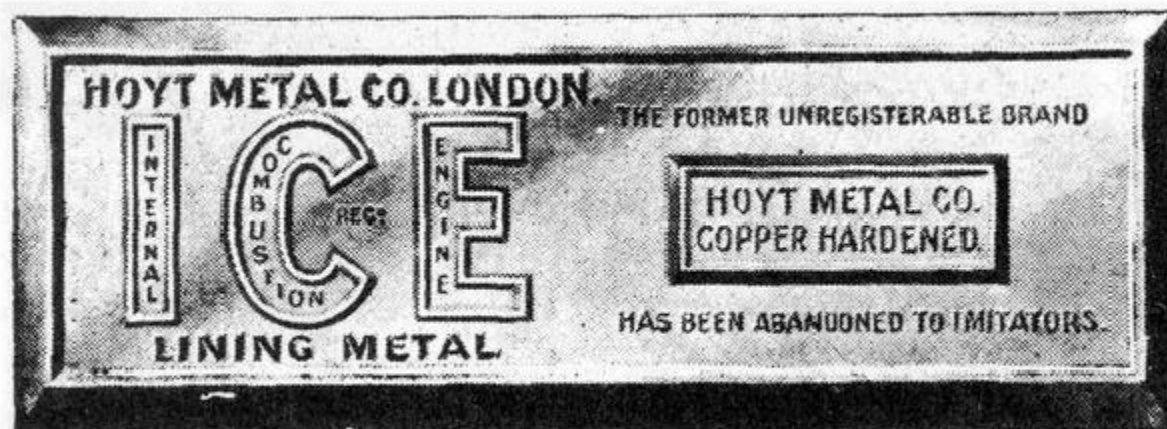

TRIAL INGOTS CHEERFULLY SUPPLIED.

RECENT RECORDS:

A.B.C. (AERO) 45 H.P. ENGINE—8 HRS. 23 MIN.

TALBOT 25 H.P. CAR—103¼ MILES IN 1 HOUR.

PEUGEOT 30 H.P. CAR—106-1/5 MILES IN 1 HOUR.

DIE-CAST BEARINGS  
FOR REPETITION WORK.

**THE HOYT METAL CO.**  
OF GREAT BRITAIN, LIMITED.  
26, BILLITER STREET, LONDON, E.C.

TWO IMPORTANT BOOKS ON AVIATION.

180 Pages, with Diagrams. Crown 8vo. 3s. 6d. net.

THE AVIATION POCKET BOOK for 1913.

**Containing amongst other valuable information, the Theory and Design of the  
Aeroplane, Structural  
Material, Examples of Actual Machines, &c., &c.**

By R. BORLASE MATTHEWS, A.M.I.C.E., M.I.E.E., *Member of the Royal Aero Club.*

CONTENTS: Air Pressure and Resistance—Aeroplane Theory and Design—Structural  
Materials—Engines—Examples  
of Actual Machines—Piloting and Aerial Navigation—Meteorological Data—Military  
Information  
and Signalling—Aero Clubs and Societies—Glossary of Terms used in Flying.

Extract from Reviews: "*... a large amount of information is included in these various chapters  
and the  
diagrams and curves used to illustrate the texture some of the plainest and most easily  
understood that we have ever seen  
in a book of this class ... generally speaking the data given would appear just such as are not  
contained in other  
books of reference.*"—Engineer.

"*The Book is one which we are sure many will find useful and convenient.*"—Engineering.

Popular Edition. 294 pages. 95 Illustrations and Dimensioned Drawings. Demy 8vo. cloth 5s.  
net.

THE ART OF AVIATION.

**A Handbook upon Aeroplanes and their Engines, with Notes upon Propellers.**

By R. W. A. BREWER, A.M.I.C.E., M.I.M.E., &c.

"*... Those who for the present have no intention of trusting themselves on the wings of an  
aeroplane will still find  
the book of value; those who already are engrossed in the study of aeronautics cannot afford to*

*ignore it.*"—Engineering.

Complete List, Post Free, from

London: CROSBY LOCKWOOD & SON,  
7, Stationer's Hall Court, E.C., & 5, Broadway, Westminster, S.W.

Dependability

In carburettors there is no greater essential than dependability, and—

The dependability of the White & Poppe is such as ensures a never-failing and invariable efficiency.

That's why it is the favourite with many of the leading Airmen of the day.

Our Booklet describes it fully, and we shall be delighted to send you copy.

**WHITE & POPPE, LTD.,**  
**COVENTRY,**  
**ENG.**

White & Poppe Carburettor



## Burberry Aeroplane Outfit.

### BURBERRY

AEROPLANE  
EQUIPMENT.

**DESIGNED BY EXPERTS** is workmanlike both in design and detail, and permits absolute freedom for arms and limbs. Made in wind and weatherproof Gabardine, lined throughout with Camel Fleece or Quilted Eiderdown, it maintains phenomenal warmth under the severest conditions.

**BURBERRY GABARDINE** is remarkably airy, yet affords perfect protection against wind, cold or rain, and is so strong that broken stays cannot penetrate its dense texture.

**Mr. C. Grahame-White:**—"I take this opportunity of thanking you for the suit I wore on my memorable flight and feel I cannot recommend the material too highly where warmth and comfort are required."

### BURBERRYS

Haymarket, S.W., LONDON;  
Boulevard Malesherbes, PARIS;  
Basingstoke and appointed Agents in Provincial Towns.

SPECIFY  
"Continental"  
RUBBER-PROOFED  
MATERIAL.

IT COMBINES  
MAXIMUM RESISTANCE  
WITH  
ENORMOUS STRENGTH,

AND IS UNAFFECTED BY  
ATMOSPHERIC CONDITIONS.

WRITE FOR LIST, FREE ON REQUEST.

Continental Tyre & Rubber Co. (Gt. Britain) Ltd.  
¾, THURLOE PLACE, LONDON, S.W.

## BLACKBURN AEROPLANES,

## HYDROPLANES

AND

## PROPELLERS.

Write for Prices and Particulars to  
THE BLACKBURN AEROPLANE Co.,

Phone,  
2822 Central.

BALM RD., LEEDS.

Telegrams: "PROPELLERS," Leeds.

## HYDROGEN

GUARANTEED 99% PURE.  
LIFTS 70½ LBS. PER 1000 CUBIC FT.

THE  
KNOWLES OXYGEN Co.

LIMITED,  
WOLVERHAMPTON

AND  
BROMBOROUGH (CHESHIRE).

## PATENTS.

Stanley, Popplewell & Co.,

INTERNATIONAL AND - -  
CHARTERED PATENT AGENTS.

38, CHANCERY LANE,  
LONDON, W.C.

Aero and Motor Patents a Specialty.

Instructive leaflet free to any address.

Telephone, 1763 Central  
Telegrams: "NOTIONS, London."

Estab. 1879.

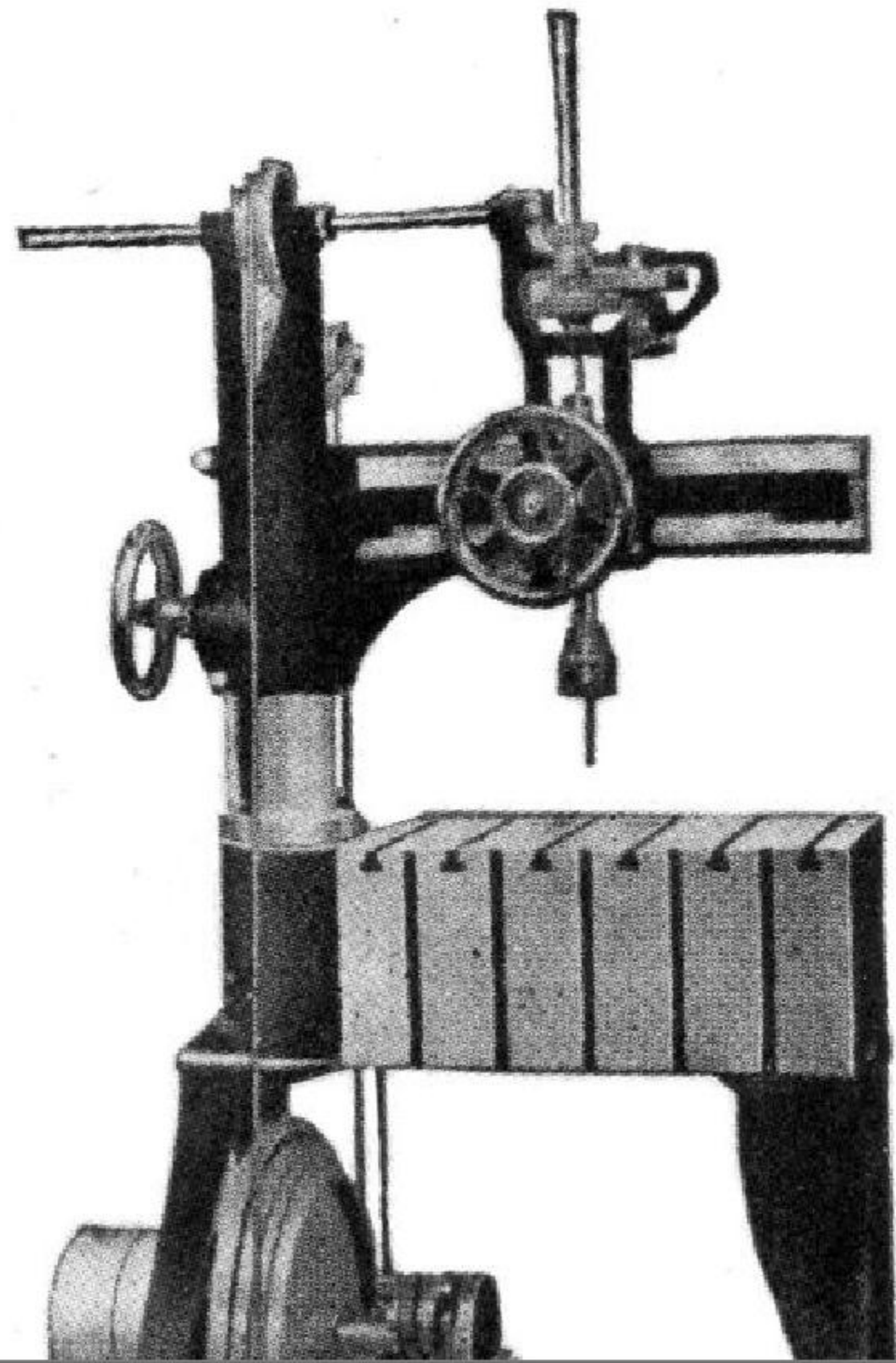
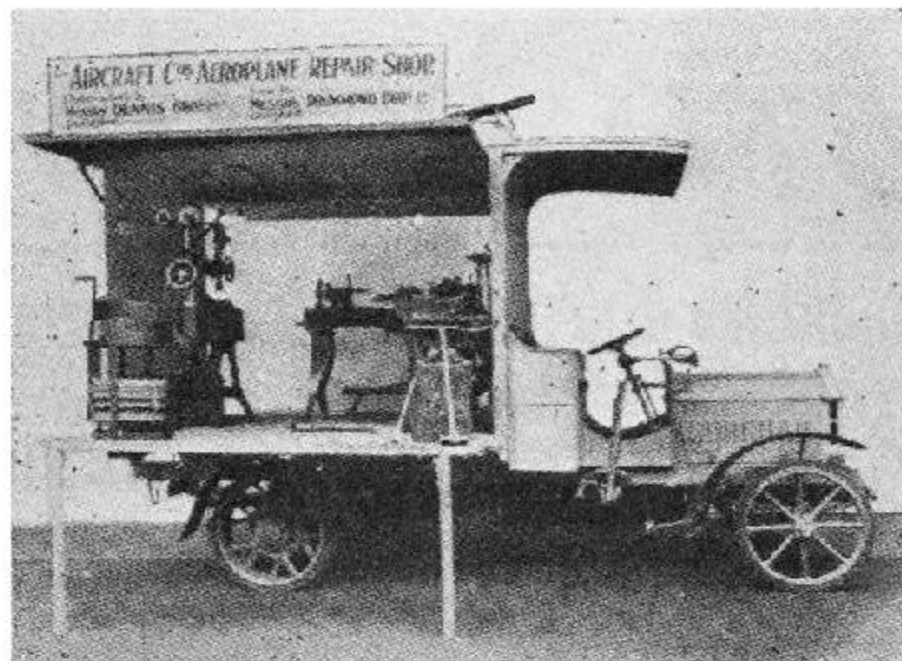



Light treadle driven Radial Drill, taking up to 1 in. drills ( $\frac{1}{2}$  in. shank.) This machine is of special design, a patented form of high speed drive giving ample power for drilling by foot. With treadle and fast and loose pulley. Price £24 15s.

We specialise in Light Machine Tools for use in portable workshops, such as are used in connection with aircraft. The above is a photograph of a Travelling Workshop equipped with our 5 in. lathe and Radial Drill, both of which tools are fitted with treadle and electric motor drive. Full particulars of machines and installations furnished on application.

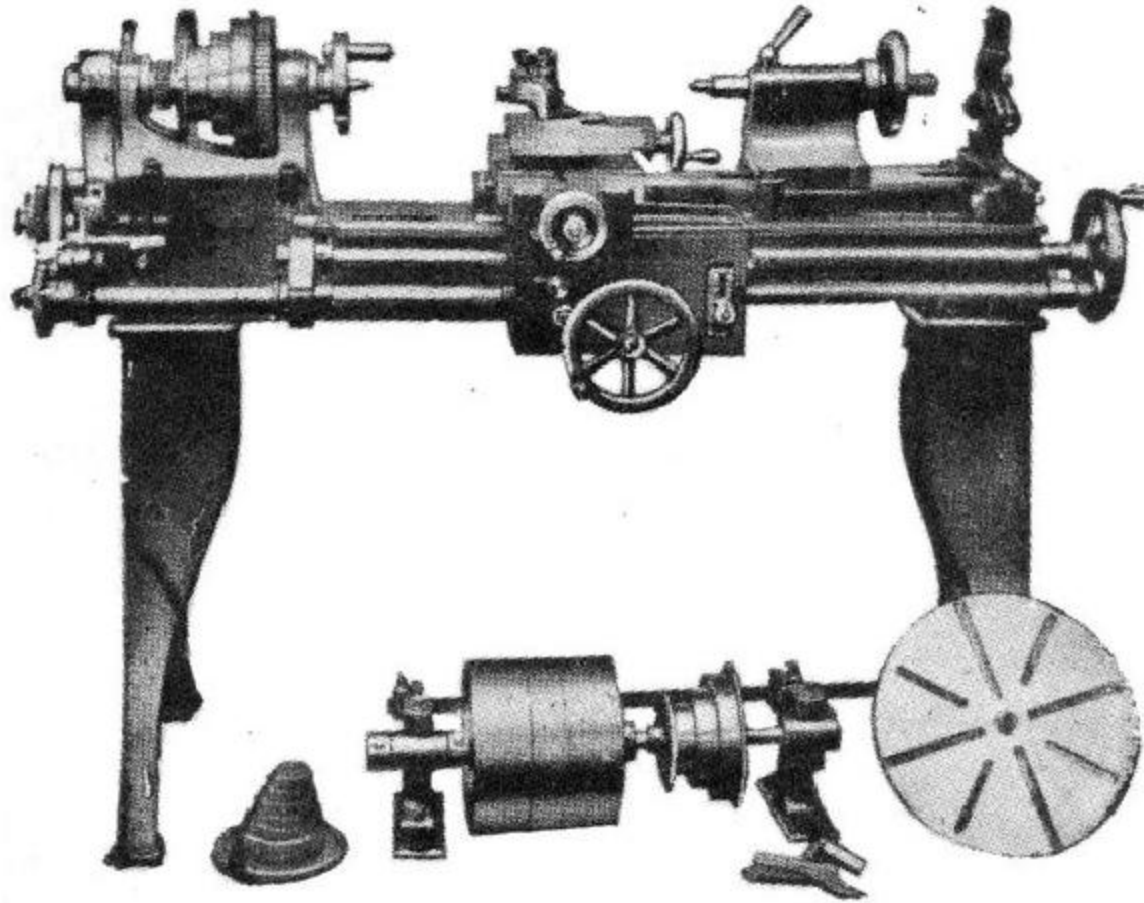

5 in. Centre Screw Cutting, Surfacing and Boring Lathe here shewn, with counter shaft for power. With counter shaft or treadle drive. Price £44.

Also 4 in.,  $3\frac{1}{2}$  in., 6 in.,  $7\frac{1}{2}$  in., 9 in. lathes, etc.

**DRUMMOND BROS. LTD.,**

REDE WORKS,  
GUILDFORD, SURREY.

'Phone 153, Guildford. Telegrams: "Lathes, Stoughton."

## "TEL" REVOLUTION SPEED INDICATORS.

Approved and used by the British Admiralty.

Owing to its conjugate movement it is accurate, possesses a uniform graduated dial and is not affected by vibration or variation of temperature.

Indicates with the same accuracy high and low speeds.

Independent of variable strains, friction.

Not damaged should maximum speed of dial be exceeded.

Rain and dust-proof.

Requires no upkeep or adjustment of mechanism.

Tel.  
431  
Victoria.

**THE HASLER COMPANY,**  
26, Victoria St., Westminster, LONDON, S.W.

**C.A.V.**

is the **proved** system of electric Lighting for Cars. The consistent reliability and efficiency of the C.A.V. Lighting Sets is vouched for by the owners of the 15,000 cars on which the system has been adopted. It is essentially the "no trouble" system; simple, safe and certain. Send for our illustrated Blue Book, fully explanatory and free.

**C. A. VANDERVELL & Co.,**  
WARPLE WAY, ACTON VALE,  
LONDON, W.

Telephones:  
1234 Chiswick  
(5 LINES)

Telegrams:  
"Vanteria,"  
London.

**Whiteman & Moss, Ltd.**

15, BATEMAN STREET,  
DEAN STREET, W.,

LONDON, England.

Telephone Gerrard 6824. Telegrams: Whitomoss

Codes { Premier.  
Lieber.  
A.B.C. 5th Edition.

**Speciality:**  
WIRE STRAINERS, EYEBOLTS, FERRULES, ETC.  
SCREWED WORK FOR ALL PURPOSES.

Accuracy & Promptitude

SPÉCIALITÉ  
de Passoires en toile métallique. de tire-fonds,  
de Viroles, etc.

Objets filetés en tous genres.  
PRÉCISION et RAPIDITÉ.

THE LEADING  
AIRCRAFT BUILDERS

ALL use the  
"INCANTO"

(LOW PRESSURE)  
OXY-ACETYLENE  
WELDING  
APPLIANCES.

SOLE MANUFACTURERS  
THORN & HODDLE ACETYLENE CO. L<sup>TD</sup>.  
151 VICTORIA S<sup>T</sup>.  
LONDON, S.W.

INSURANCE.

The Primus Aviation Policy at Lloyd's

OFFICIALLY APPROVED BY  
THE ROYAL AERO CLUB.



For Advice on:—

AVIATION, LIFE, PERSONAL ACCIDENT,  
3rd PARTY, EMPLOYERS' LIABILITY,  
MOTOR, and all Classes of Insurance

communicate with  
BRAY, GIBB & Co., Ltd.,  
166, PICCADILLY,  
LONDON, W.

Telegram—"SOPWITH KINGSTON." Telephone—1177, KINGSTON.

SOPWITH AVIATION Co.

THE SOPWITH MACHINES hold the British RECORDS for:

DURATION . . . 8 hours 23 minutes.

ALTITUDE . . . . . 11,450 feet.

Undergoing War Office Tests, the SOPWITH 80 h.p. TRACTOR BIPLANE gave better results than any aeroplane of whatever nationality previously tested.

OFFICES AND WORKS:

CANBURY PARK ROAD, KINGSTON ON THAMES.

CONTRACTORS  
TO THE  
ADMIRALTY.

MANUFACTURERS  
OF  
AEROPLANES

AND  
HYDRO-AEROPLANES

HARDWOODS FOR AEROPLANES.

UNEQUALLED FACILITIES FOR SUPPLYING PERFECT TIMBER.  
SPECIAL SKILL AND GREAT EXPERIENCE DEVOTED TO ORDERS FOR AEROPLANE  
WOODS.

ALL KINDS OF HARDWOODS IN PLANKS, OR CUT AND PLANED TO SIZE.

Testimonials from successful Aviators.

WILLIAM MALLINSON & SONS, Limited,

TIMBER & VENEER MERCHANTS (Direct Importers & Exporters),

130-138, Hackney Road, LONDON, N.E.

Telegram: "ALMONER," LONDON.

Telephone: 4770 LONDON WALL (2 Lines)  
P.O. 3845 CENTRAL.

CORRESPONDENCE IN ANY LANGUAGE.

PARIS: 7, Rue Titon.

ROTTERDAM: 22 Westzeeddijk.



## THE "MARTINSYDE"

120 H.P. TWO-SEATER, MILITARY TYPE MONOPLANE.

Fuel Capacity for 6 HOURS' FLIGHT, at 85 miles per hour.

*Messrs. Martin & Handasyde,*

— BROOKLAND AVIATION GROUND, —  
WEYBRIDGE, SURREY, ENGLAND.

Telegraphic & Cable Address:  
"MARTINSYDE, WEYBRIDGE."

Telephone No.  
171 BYFLEET.

CONTRACTORS TO THE WAR OFFICE.

## "AVIATOR" RAMIE FABRICS FOR AEROPLANES AND DIRIGIBLE BALLOONS.

Indisputably the **strongest, most durable** and **efficient** of all known fabrics, and consequently adopted by H.M. War Office, and the leading **Aircraft Constructors** of the **Universe.**

Manufactured from China Grass by

La Maison Esnault-Pelterie (Paris)

Barbet-Massin, Popelin & Cie, Succrs.

**Contractors to the French Government.**

Sole agents for the United Kingdom, British Colonies, and United States of America—

### ROGERS BROTHERS,

Telephone: CENTRAL, 12164.

Telegrams and Cables: "EGYPTILLO, LONDON."

A.B.C. Code Used, 5th Edition.

33, ALDERMANBURY,  
LONDON, E.C.

Write for Patterns and  
Particulars.

Cables and Telegrams: "PIGGOTT, LONDON." A.B.C. Code. 5th Edition. Telephone No. London Wall 4850 (Private Exchange).

## PIGGOTT BROTHERS & CO., LIMITED.

Portable Canvas Aeroplane Sheds on Hire, for Prize Contests, Flying Meetings, etc.  
As used for the Gordon Bennett and "Daily Mail" Contests, Military Manvres, 1911, and the  
Flying Meetings at

Doncaster, Burton-on-Trent, Folkestone, etc., etc.

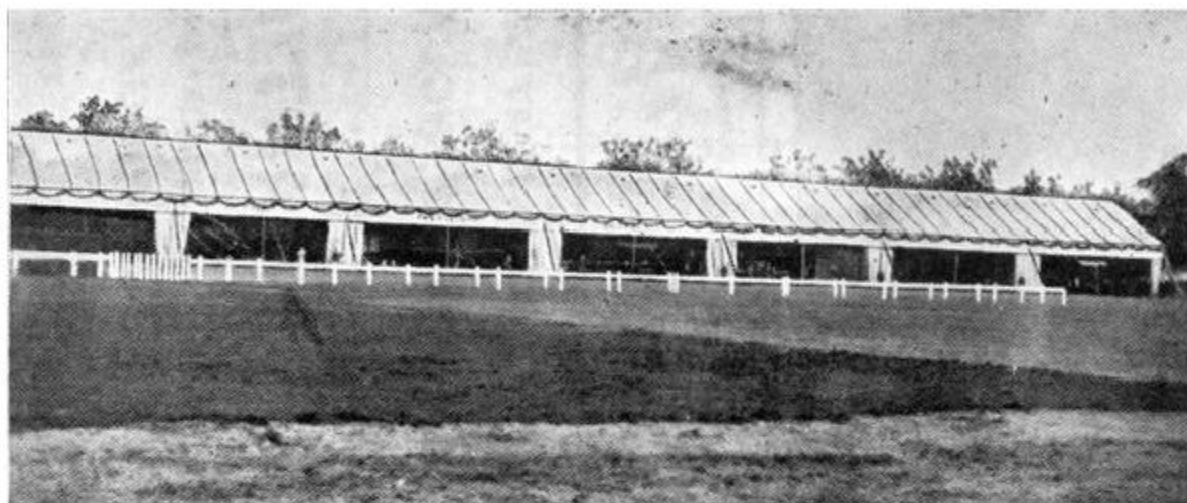

Photo showing row of Canvas Sheds as erected at Brooklands for the Royal Aero Club, July,  
1911.

**Large Stock of Goods for Hire at Prize Contests, Flying Meetings, etc., Judges' Boxes,  
Pylons, Ropes and Stakes for course, Canvas Fencing, Signal Masts, etc., etc.**

**220, 222, 224, BISHOPSGATE, LONDON, E.C.**

*Telephone 3811 HOP.—Telegrams: "BUCHERON."*

**Joseph Owen & Sons, L<sup>imited</sup>,**

SUPPLY EVERY DESCRIPTION OF

—TIMBER—

FOR

**Aeroplanes, Hydroplanes, Airships.**

SEND YOUR ENQUIRIES TO

**199a, BOROUGH HIGH STREET, LONDON, SE.**

# FLANDERS

MONOPLANES & BIPLANES

—For Land or Water.—

L. HOWARD-FLANDERS, LIMITED,  
31, Townshend Terrace,  
RICHMOND, Surrey.

Types 8 volts 9 amps.  
12 volts 15-20 amps.

## Eisemann Automatic Advance Magneto

Used on the Mercedes—Gnome—Schutte Lanz—Dixi, etc., etc. Entirely weatherproof—advances and retards the spark periodicity according to engine revolutions. Latest models as used on above engines both single and dual.

Fullest Particulars on hearing from you.  
**THE EISEMANN MAGNETO Co.**  
43, Berners Street, W.

Telegrams:—  
Roussillon-ox, London.  
Telephone 4601 City.  
A.B.C. Code 5th Edition.

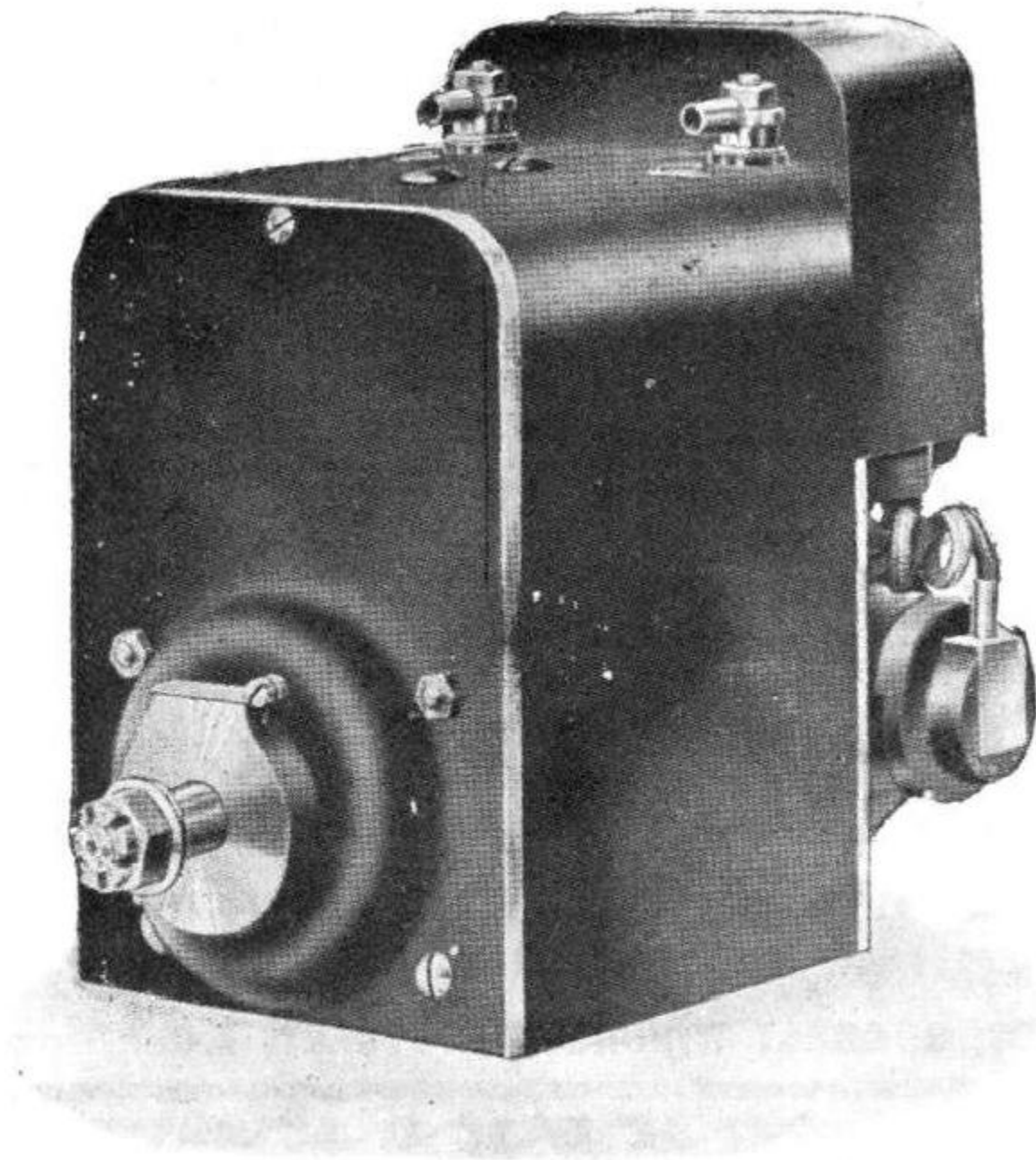

## EISEMANN DYNAMO

Although designed for use with accumulators—gives results without damaging filaments without the use of accumulators. Perfectly automatic in action. Used on the Zeppelin.

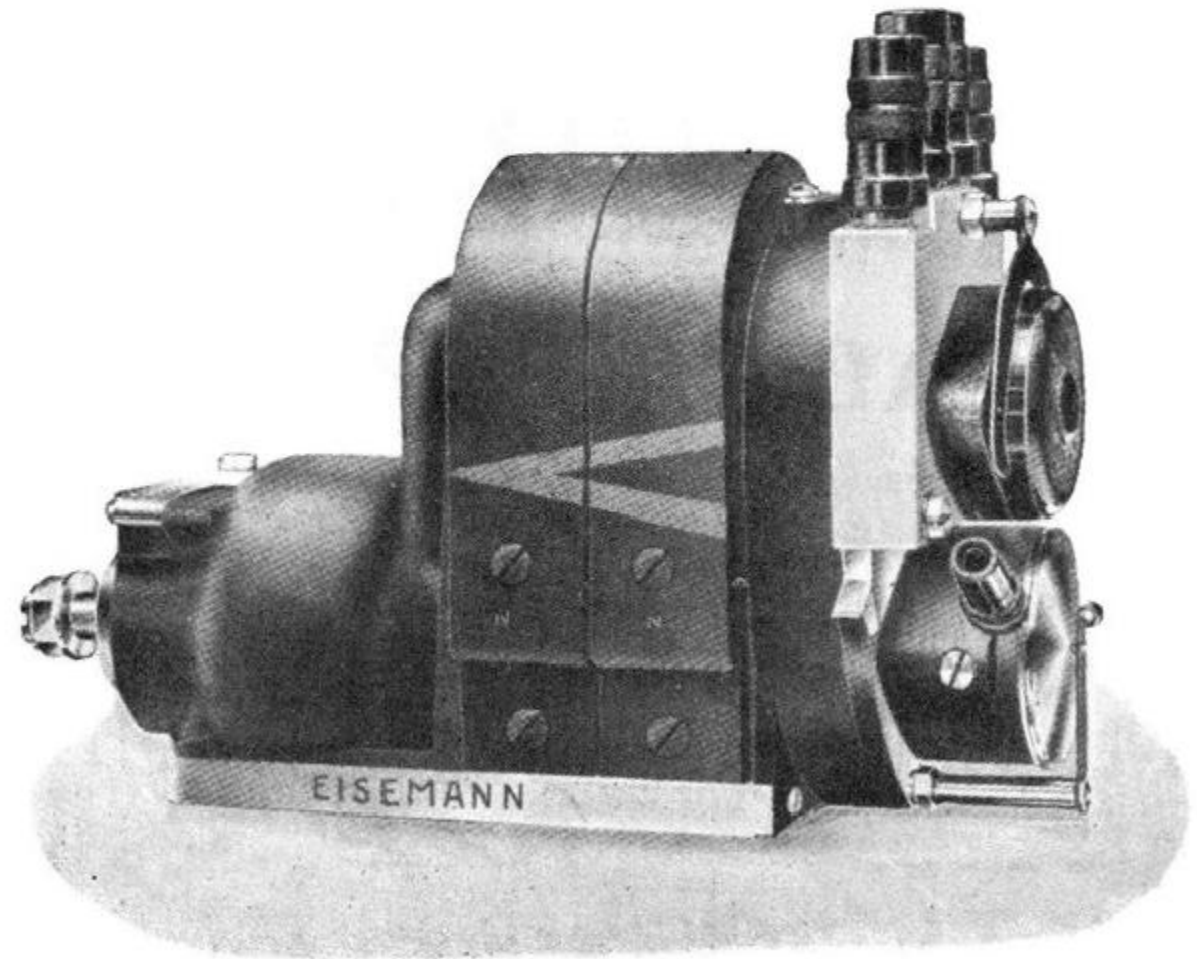

# The Aircraft of the World

perform best on the best Spirit. The rapidly growing  
*Preference for PRATT'S*

## Perfection Motor Spirit

among airmen is a repetition of history. In Motoring, on the Road, the consistent Purity and Reliability—the sheer, hard, practical Service of "Miles to the Gallon" has long established PRATT'S as the premier Motor Spirit.

*"In Earth and Skie and Sea"—PRATT'S first shall be!*



By Appointment

**In the Air, as on the Road, PRATT'S is "THE MOVING SPIRIT OF THE AGE!"**

Telegraphic Address: "JONBRO," MANCHESTER.

## JONES BROTHERS

LIMITED,  
Spinners & Manufacturers,  
12, YORK STREET,  
Manchester.

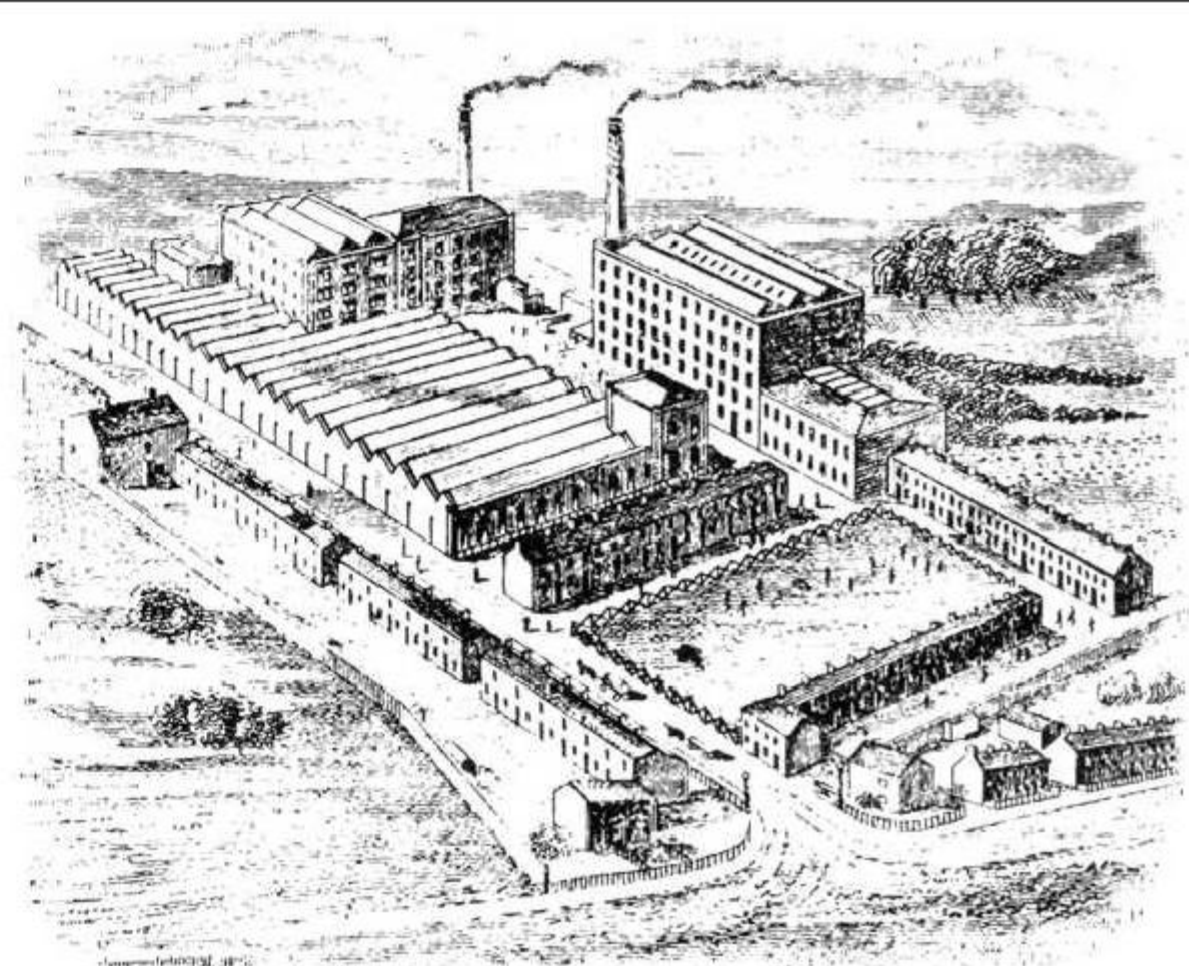

BEDFORD NEW MILLS,  
LEIGH, LANCASHIRE.

## THE "AERO"

Cotton Fabrics  
for Aeroplanes.

## H. VALDENAIRE, ADENET & Cie.

PARIS—21, Rue des Jeuneurs—PARIS.

## TISSUS DE GRANDE RÉSISTANCE

FOURNISSEURS HABITUELS des PRINCIPALES MARQUES d'AVIATION et  
d'AEROSTATION

## KEMP MOTORS

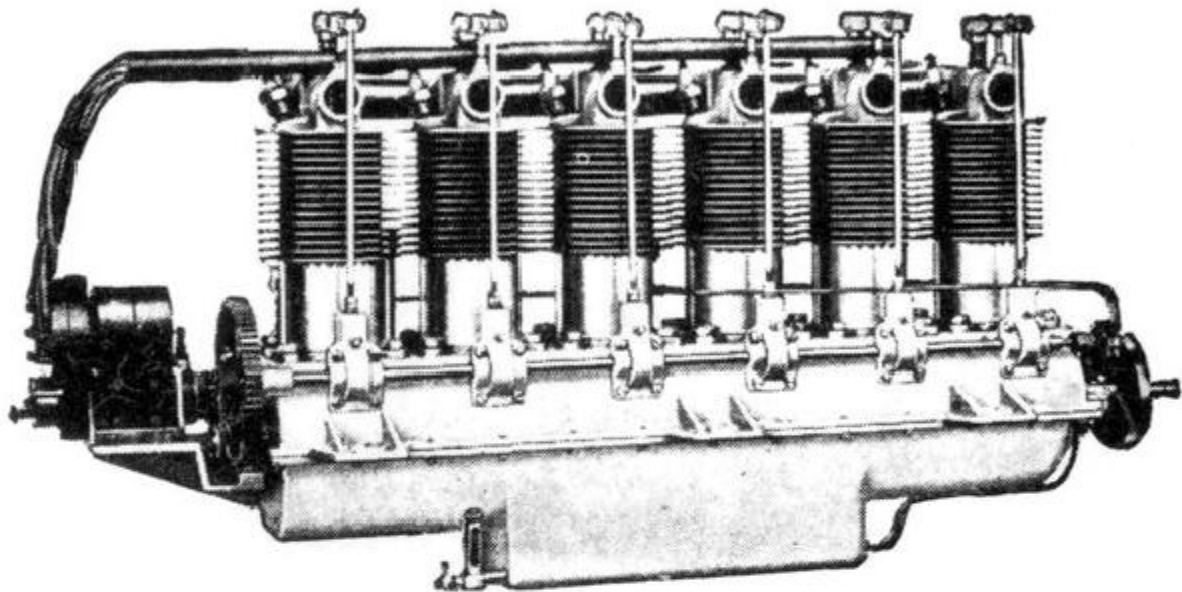

Are air cooled and are the most efficient, economical and reliable power plants on the market sold at reasonable prices. Built in four sizes to meet all requirements from experimental purposes to commercial use.

FULL PARTICULARS ON REQUEST.

KEMP MACHINE WORKS,  
MUNCIE, INDIANA, U.S.A.

"AFTER 13 HOURS UNDER WATER"

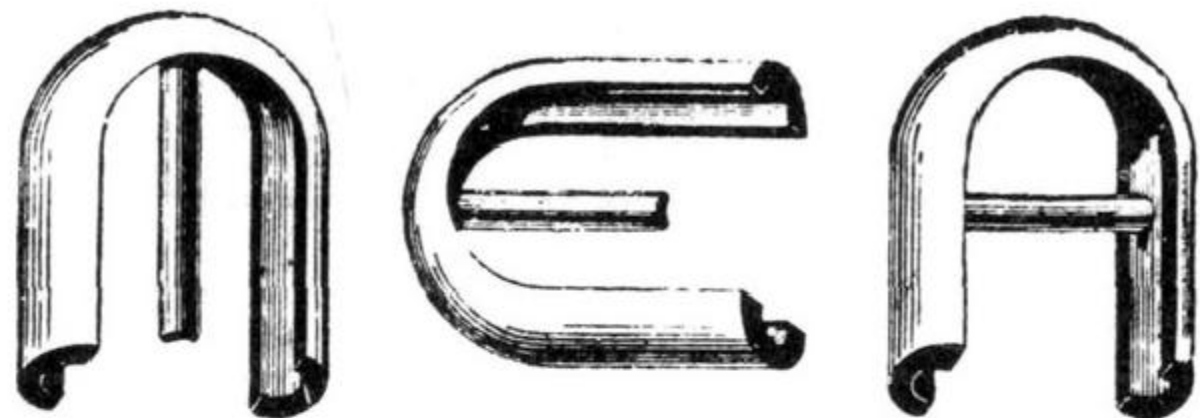

THE MEA

*(The Magneto with the Bell-shaped Magnet)*

RAN PERFECTLY.

"One of your Magnetos delivered to us last year has had a severe test, proving it to be absolutely waterproof. It was fitted to an engine in a motor boat, which towards 7 p.m. ran full of water: next morning about 9 a.m. we pumped her dry, and, after your magneto had been about 13 hours under water, it was found to be in perfect working order, and the engine started up without a hitch."

MEA MAGNETO CO., LTD.,

Telephone: 2580 Regent.  
Telegrams: "Meabermag, Ox. London"

GRESSE BUILDINGS, STEPHEN STREET,  
TOTTENHAM COURT RD., LONDON, W.

LONDON AGENTS: B. M. FAIR & CO., 3, GREAT WINCHESTER STREET, E.C.  
C.D.C.

# BRANGER,

Aerial Photographer,  
5, Rue Cambon, 5

PARIS.

## "Fighting Ships"

NAVAL ANNUAL  
FOR 1913.

Founded and Edited by FRED T. JANE,  
*Founder & Editor "ALL THE WORLD'S AIRCRAFT."*

PLANS, PHOTOGRAPHS, AND ALL DETAILS  
OF EVERY WARSHIP IN THE WORLD.

The details of **13** Navies are officially revised by order of their respective Ministers of  
Marine; **3** others semi-official.

SPECIAL ARTICLE ON "MARINE ENGINEERING IN ALL ITS BRANCHES," by  
C. de GRAVE SELLS, M. Inst. C.E.

LONDON: SAMPSON LOW, MARSTON & Co., Ltd.

THE "MASCOT"  
RAMIE-FIBRE, ROT-PROOF

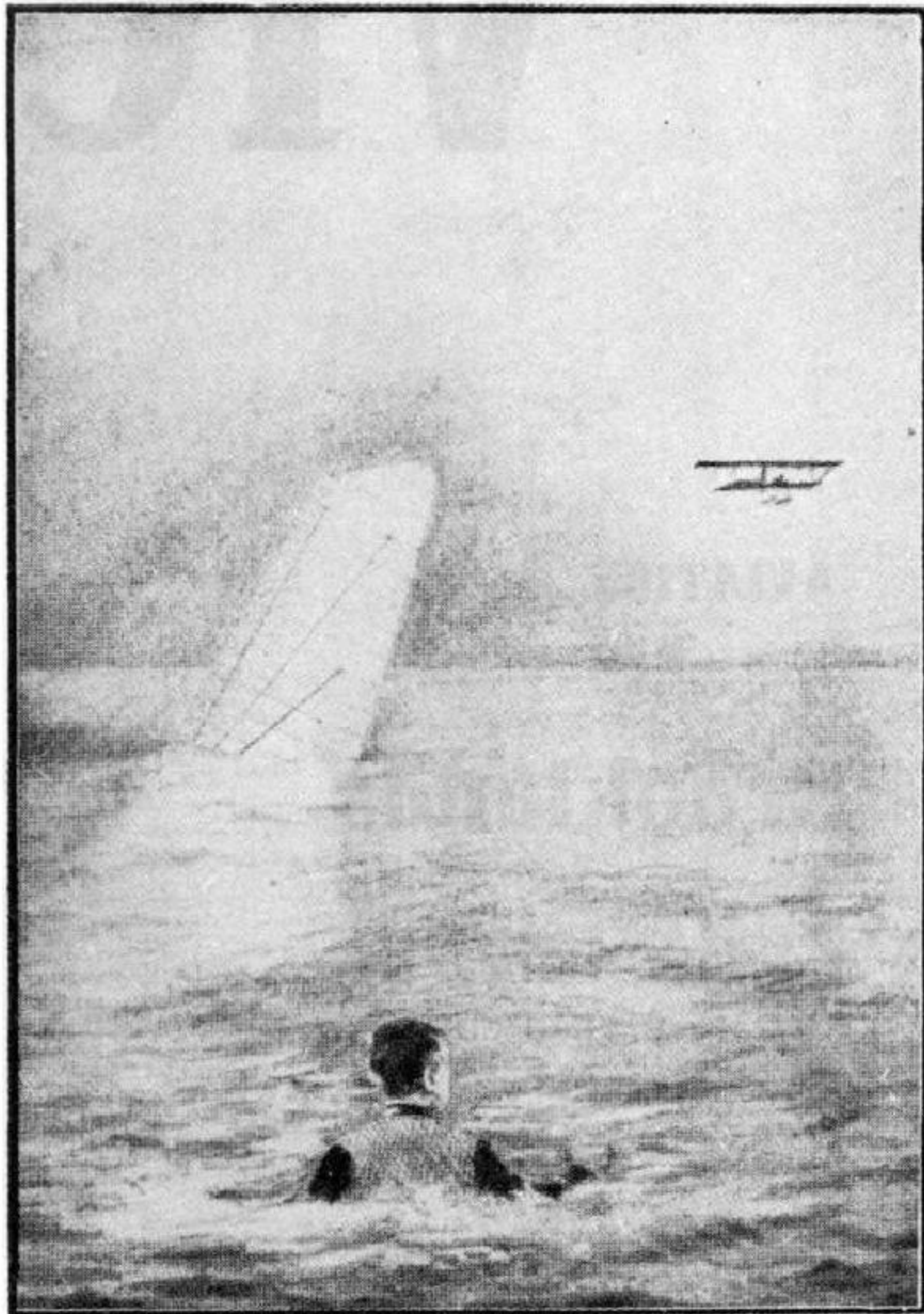



# LIFE-SAVING VEST

Stocked by the Leading Stores in all Countries, or can be purchased direct from the Inventors and Sole Manufacturers—

## ROGERS BROTHERS,

Manufacturers of "Aeroplatte" All-British Aircraft Fabrics, and the "Aeromac" Water-proof Garments

33, ALDERMANBURY, LONDON, E.C. Send post-card for full particulars.

Telephone, Central, 12164

Telegrams & Cables: "EGYPTILLO, London."

A B C Code used. 5th Edition.

## VICKERS LIMITED.

AVIATION  
SCHOOL:

**Brooklands.**

Thorough Tuition from slow Biplanes to fast Monoplanes.  
Special Terms to Naval and Military Officers.

Aviation School:

**Brooklands.**

**"VICKERS-LEVASSEUR"**

**Air Screws.**

Built up in superposed layers, of the finest quality of thoroughly seasoned hardwoods, pegged & glued together.

**Testing Ground:**

**Joyce Green,  
Nr. Dartford.**

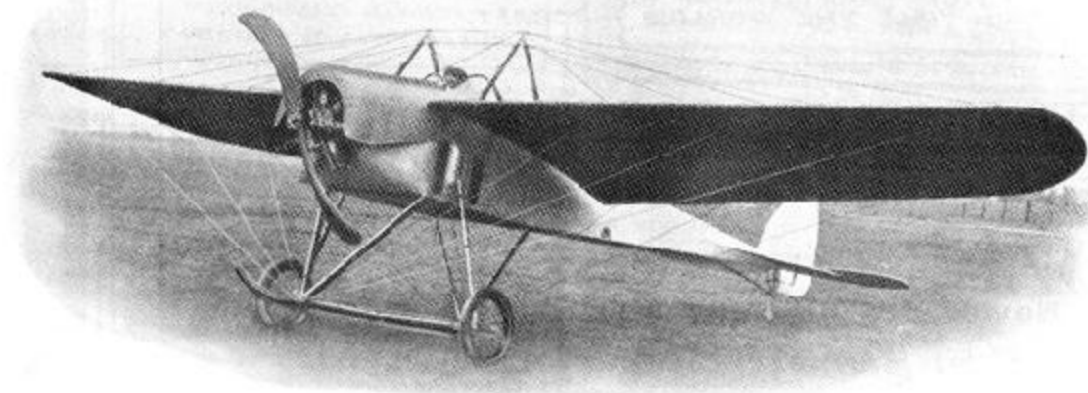

## AEROPLANES.

All steel-framed Monoplanes, Biplanes & Hydro-planes.

AVIATION DEPARTMENT:

VICKERS HOUSE, BROADWAY, WESTMINSTER, S.W.

End of Project Gutenberg's Jane's All the World's Aircraft, by Various

\*\*\* END OF THIS PROJECT GUTENBERG EBOOK JANE'S ALL THE WORLD'S AIRCRAFT \*\*\*

\*\*\*\*\* This file should be named 34815-h.htm or 34815-h.zip \*\*\*\*\*  
This and all associated files of various formats will be found in:  
<http://www.gutenberg.org/3/4/8/1/34815/>

Produced by Suzanne Shell, Jason Isbell and the Online Distributed Proofreading Team at <http://www.pgdp.net>

Updated editions will replace the previous one--the old editions will be renamed.

Creating the works from public domain print editions means that no one owns a United States copyright in these works, so the Foundation (and you!) can copy and distribute it in the United States without permission and without paying copyright royalties. Special rules,